





In recent years we have experienced many great advances in scale modeling, in fact, many say that we are living in the "golden age" of modeling. With an ever increasing number of new modeling brands and manufacturers, subjects that were only a distant dream only a few years ago are now available to us. In this increasingly crowded market, AK Interactive retains leadership. Our advantage is a result of our relentless pursuit of innovative ideas and our commitment to the modeler. AK Interactive is the benchmark by which all others are measured. The products shown in this catalogue are carefully designed, developed and tested in order to provide you with the highest standard of any products found on the market, satisfying the needs of both the professional and beginning modeler alike. Due to their ease of use and excellent results, our products open new possibilities for even for the most demanding modeler, those who insist upon maximum realism on their models as they explore and experiment with new products and original ideas. Even this catalogue is an innovative product, packed with inspiring images of models from the most famous modelers in the world. We intend this catalogue to be a collectable item, a lasting reference to help expand your modelling knowledge regardless of your skill level. In addition, you will find that our range of products is complimented with highly informative and beautiful modeling manuals and techniques books, which are the finest on the market. All this, coupled with the best service and attention from everyone in our company, have made us the most reputable brand in the industry.

Fernando Vallejo
AK Interactive Spain

Durante los últimos años hemos vivido grandes avances en lo que al modelismo se refiere. Con la aparición de nuevas marcas de plástico se han cubierto la mayor parte de las variantes posibles que no estaban en el mercado. Paralelamente empresas como la nuestra han evolucionado aún más y han marcado una línea a imitar en lo que al acabado de estos modelos se refiere. Desde una posición líder en el mercado y un equipo que continuamente ha innovado en los productos, AK marca actualmente el paso a seguir en cuanto a calidad, imagen e ideas. Los productos de este catálogo han sido cuidadosamente diseñados, desarrollados y testados para poder ofrecer los mejores estándares del mercado. Tanto para modelistas profesionales como para principiantes, gracias en parte a su facilidad para usarlos y también al soporte de nuestra empresa para promocionar y expandir el mundo del modelismo. Este tipo de productos ha abierto nuevas posibilidades a modelistas inquietos que quieren buscar en sus modelos el máximo realismo y les gusta investigar y experimentar con nuevos productos. Actualmente este catálogo en sí mismo es también un producto innovador, con maquetas de los modelistas más famosos del mundo. Un manual que ha supuesto una forma distinta de presentar los productos, objeto de coleccionistas e imitación por otras marcas. El rango de productos se completa con los manuales y libros de técnicas mas prácticos y demandados del mercado, todo esto con el mejor servicio y atención por parte de todos los miembros de la empresa que hacen de ella una de las más reputadas del sector con presencia en todos los países del mundo.

Fernando Vallejo
AK Interactive España

Produced and distributed by



www.ak-interactive.com

Design and layout:
Virginia Sigüenza

AK INTERACTIVE / 2

Follow us on

INDEX / ÍNDICE

4	1. Color research, development and manufacturing process / <i>Investigación del color, desarrollo y proceso de fabricación.</i>
6	2. AKrylics / <i>AKrísticos</i>
6	2.1 Akrylic paints / <i>Pinturas acrílicas</i>
10	2.2 Generic Sets / <i>Sets genéricos</i>
12	2.3 AFV series / <i>Serie de vehículos armados</i>
18	2.4 AIR series / <i>Serie de aviones</i>
22	2.5 Figure series / <i>Serie de figuras</i>
26	2.6 Naval series / <i>Serie naval</i>
27	2.7 Civil series / <i>Serie civiles</i>
28	2.8 Color conversion chart / <i>Tabla de conversión de colores</i>
34	3. Metal colors / <i>Colores metálicos</i>
34	3.1 Xtreme Metal
36	3.2 True Metal
38	4. Real Colors / <i>Colores reales</i>
40	4.1 AFV book, Basic and AFV colors, color sets / <i>AFV libro, Colores básicos y AFV, Set de colores</i>
44	4.2 AIR book and AIR colors, Aircraft sets / <i>AIR libro y AIR colores, Set de Aircraft</i>
50	4.3 Color conversion chart / <i>Tabla de conversión de colores</i>
54	5. Sprays / <i>Pulverizadores</i>
56	6. Weathering products / <i>Productos de envejecimiento</i>
56	6.1 Filters / <i>Filtros</i>
56	6.2 Engine effects / <i>Efectos de motores</i>
57	6.3 Streaking effects / <i>Efectos de chorretones</i>
57	6.4 Dust, mud and nature effects / <i>Efectos de barro, polvo y naturaleza</i>
58	6.5 Special deposits / <i>Depósitos especiales</i>
58	6.6 Washes / <i>Lavados</i>
59	6.7 Paneliners / <i>Paneladores</i>
60	6.8 Pigments / <i>Pigmentos</i>
62	6.9 Weathering sets / <i>Sets de envejecimiento</i>
66	6.10 Weathering pencils / <i>Lápices para el envejecimiento</i>
68	7. Diorama products / <i>Productos para dioramas</i>
68	7.1 Water, snow & ice / <i>Agua, nieve y hielo</i>
70	7.2 Terrains / <i>Terrenos</i>
71	7.3 Splatter and crackle effects / <i>Efectos de salpicaduras y craquelados</i>
72	7.4 Specials / <i>Especiales</i>
72	7.5 Building materials / <i>Materiales de construcción</i>
74	7.6 Vegetation / <i>Vegetación</i>
82	8. Auxiliary products / <i>Productos auxiliares</i>
82	8.1 Thinners & cleaners / <i>Disolventes & Limpiadores</i>
83	8.2 Varnishes / <i>Barnices</i>
86	8.3 Primers / <i>Imprimadores</i>
88	8.4 Glues & fixers / <i>Pegamentos & Fijadores</i>
89	8.5 AK Specials / <i>AK Especiales</i>
91	8.6 Putty & paste / <i>Masillas & Texturas</i>
92	9. Tools & accessories / <i>Herramientas & Accesorios</i>
92	9.1 Paint tools / <i>Herramientas para pintar</i>
93	9.2 Modeling tools / <i>Herramientas de modelar</i>
95	9.3 Tools / <i>Herramientas</i>
99	9.4 Masking tape / <i>Cinta de enmascarar</i>
100	9.5 Sandpaper / <i>Papel de lija</i>
102	9.6 Brass Pipe / <i>Tubos de latón</i>
104	9.7 Airbrush & replacements / <i>Aerógrafo y repuestos</i>
108	9.8.Brushes / <i>Pinceles</i>
110	9.9 Accesories / <i>Accesorios</i>
114	10. Media / <i>Impresión y audiovisuales</i>
114	10.1 Books / <i>Libros</i>
114	10.1.1 F.A.Q. / <i>Preguntas frecuentes</i>
116	10.1.2 Learning series
118	10.1.3 Modeling books / <i>Libros de modelismo</i>
123	10.1.4 Profile books / <i>Libros de perfiles</i>
124	10.1.5 History books / <i>Libros de historia</i>
128	10.2 Magazines / <i>Revistas</i>
136	11. Merchandising
136	11.1 Special bags & deluxe transport boxes / <i>Maletas especiales y cajas de transporte de lujo</i>
138	11.2 Merchandising
140	11.3 Display racks / <i>Expositores</i>

© 2021 AK Interactive.

All rights reserved. No part of this publication may be reproduced or transmitted in any form or by any means, electronic or mechanical, actual or future, including photocopy, recording or any information storage or retrieval system, without permission in writing from the publishers.



WHO WE ARE / QUIÉNES SOMOS

With a unique passion for creation and innovation, AK Interactive is a dynamic Spanish company that develops innovative products for the world of modeling. The company has its headquarters located in the small town of Logroño (La Rioja), a region which is known for its wines that are exported all over the world. Our company has achieved its exceptional reputation over the years, thanks to our outstanding employees and the many talented collaborators working with us from around the world. Since its creation in 2008, the company has grown and evolved, adapting to the needs of modelers, realized by the commitment of its departments which incorporate the most brilliant professionals in the sector. The products that you can find here have been developed thanks to the work of this professional team. Today, our publications and products are the guides and consumables for many modelers.

The history of this company is full of mystery and myth, but the reality is that AK Interactive is a highly tuned instrument built to generate ideas and products of the highest quality that the market demands. Like all mysteries, it was born and idealized in the minds of many modelers and customers who, despite everything, put their trust in the brand from the outset and opted for originality. This is precisely the key to the success of the company that was destined as a market leader, thanks to its ideas and products.

The AK team consists of a large group of professionals, from artists to designers, modelers, researchers, chemists, salesmen and a strong administrative department that controls all activities in the factory. This team has been steadily expanding since the beginning. Also, many people around the world participate in projects such as the creation of books, magazines, DVDs, etc.

Con una pasión única por la creación y la innovación, AK Interactive es una empresa española dinámica que desarrolla productos innovadores para el mundo del modelismo. Se encuentra en la pequeña ciudad de Logroño (La Rioja), que es conocido por sus vinos que también se exportan a todo el mundo. Nuestra compañía ha logrado su reputación a lo largo de los años, gracias a sus empleados y a los muchos colaboradores que posee en todo el mundo. Desde su creación en 2008, la compañía ha crecido y evolucionado, adaptándose a las necesidades de los modelistas. Gracias a todos sus departamentos que incorporan a los profesionales más brillantes del sector y a la red de distribuidores y tiendas ha conseguido colocarse como referencia en la mayor parte de países del mundo. Los productos que puede encontrar en este catálogo se han desarrollado gracias al trabajo de un equipo profesional. Hoy en día, nuestras publicaciones y productos son las guías de referencia y consumibles para muchos modelistas.

La historia de esta empresa está llena de misterio y mitos, pero en realidad, es solo una máquina para generar ideas y productos de la más alta calidad que exige el mercado. Como todos los misterios, nació e idealizó en la mente de muchos modelistas y clientes que, a pesar de todo, depositaron su confianza en la marca desde el principio y optaron por la originalidad. Esta es precisamente la clave del éxito de la empresa que se proyectó como líder del mercado, gracias a sus ideas y productos.

El equipo de AK se compone de un gran grupo de profesionales, artistas, diseñadores, modelistas, investigadores, operarios, químicos, comerciales y un potente departamento administrativo que controla todas las actividades en la fábrica y almacén. Todo del personal ha estado en constante expansión y desarrollo profesional desde sus orígenes. Además, contamos con diversas personas en todo el mundo que participan en proyectos como la creación de libros, revistas, material audiovisual, etc.



1

COLOR RESEARCH, DEVELOPMENT AND MANUFACTURING PROCESS / INVESTIGACIÓN DEL COLOR, DESARROLLO Y PROCESO DE FABRICACIÓN

RESEARCH / INVESTIGACIÓN

AK Interactive works and collaborates with many people to achieve the most accurate colors. Military historians and paint specialists join forces with modellers to find the most exact formula for each color. Specialists, along with the artist/modeller, search and study the right shade for each color in order to prepare color samples. If paint can be extracted directly from the original object, a sample will be delivered to the AK headquarters and the factory for analysis.

AK Interactive trabaja y colabora con mucha gente para conseguir los colores más adecuados. Historiadores, militares y especialistas en el tema, unen sus fuerzas con modelistas para encontrar el patrón más exacto de cada color y los tonos correctos. Cuando es posible se consiguen los colores directamente de los objetos originales, y se pintan las muestras correspondientes que se envían a las instalaciones de AK Interactive para su análisis.



COLOR DEVELOPMENT AND ADJUSTMENT / AJUSTE Y DESARROLLO DE LOS COLORES

COLOR SCAN / ESCANEADO DEL COLOR

Color samples arrive in two ways: the color comes already applied on a sheet or original item, or it comes in a jar which we then apply over a sheet. From the sheet we read it with a spectrophotometer which gives us its coordinates and color curves.

Nuestros colores llegan en dos posibles formas; bien aplicados en una cartulina de muestra o directamente en un envase del que se pinta una muestra. La muestra de color en la cartulina se lee en un espectro-fotómetro con el que se obtienen las coordenadas y curvas de color por parte del químico del laboratorio.

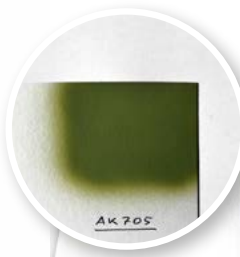

CALIBRATING THE FORMULA / CALIBRANDO LA FÓRMULA

With our cutting-edge colour formulation software, which has been previously calibrated and adjusted to our raw materials, we start working to achieve the desired color. We input all necessary parameters. This way, the software gives us a formula to reproduce the color, taking into account not only the overall color appearance, but its complete color curve and the effects of different lighting sources such as daylight, incandescent, and fluorescent light.

Con nuestro software de formulación de color de última generación, que previamente se ha calibrado y ajustado a nuestras materias primas, se empieza el trabajo de obtención del color adecuado. Se introducen los distintos parámetros, como el índice de cobertura, los pigmentos a usar, etc... para que el software nos de la fórmula para reproducir el color teniendo en cuenta no solo su apariencia general, sino además su curva de color completa y los diferentes efectos de luz como la luz diurna, incandescente y fluorescente.

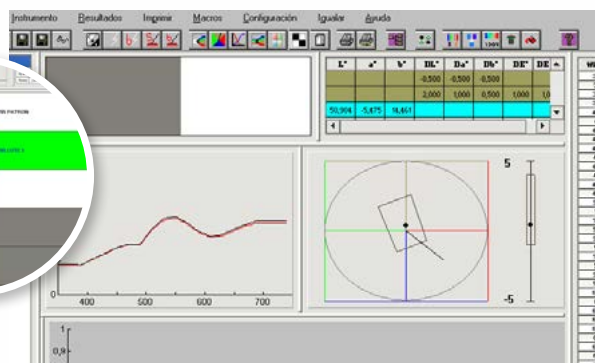

2.3 MATCHING ACCURACY / AJUSTE DE LA PRECISIÓN

We produce the suggested formula from the software and apply it over a sheet to compare it with the original pattern to check for any slight differences. Usually, the software gives us a very close result to the original, but not a perfect match. Once again, with the spectrophotometer, we take the data of the new color and correct it with our software to adjust it to the original pattern.

Se produce la fórmula sugerida por el software y se aplica sobre una cartulina de muestra para compararla con el patrón original, y así comprobar las posibles diferencias. Normalmente el software nos da un resultado muy cercano al original, aunque no siempre exacto. De nuevo, con el espectro-fotómetro, tomamos los datos del nuevo color y lo corregimos con el programa para ajustarlo al patrón original.

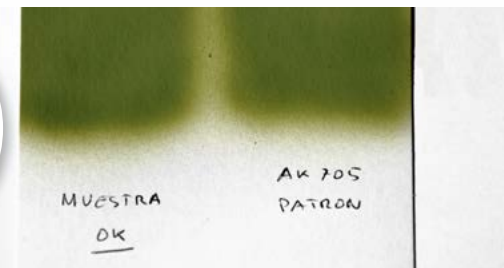

2.4 FINAL TEST / PRUEBA FINAL

The normal process is to make two corrections over the first input. Once ready, we send it to the responsible person to get their approval and get it ready for production.

El proceso normal consiste en dos correcciones sobre el primer resultado. Una vez todo correcto, se manda a la persona responsable de supervisar el resultado y ya tenemos el color listo para su producción.



MANUFACTURING / FABRICACIÓN

PRODUCTION / PRODUCCIÓN

Once production starts, we make another test over a plastic sheet to check coverage, quality and color. If for any reason there has been any change in the parameters, we fix it until it is correct. We keep a color swatch of each color manufactured.

Una vez la producción comienza, hacemos una nueva prueba sobre una cartulina de muestra para comprobar la capacidad de cobertura, calidad y color de cada referencia. Si por cualquier razón se hubiera producido un cambio en los parámetros, se modifican hasta corregirlos. Finalmente se archiva una muestra de cada color.

QUALITY / CALIDAD

This color development and manufacturing procedure is protected and audited under the ISO 9001 quality standard.

Este procedimiento de desarrollo y fabricación está protegido y auditado bajo el estándar de calidad ISO 9001

AT THE FACTORY / EN LA FÁBRICA

PAINT CREATION PROCESS / PROCESO DE CREACIÓN DE LAS PINTURAS

In AK Interactive, we want to show you how our paints are created in our factory. The previous process is more complicated as colors have to be tested over and over again until we achieve the proper and absolute shade. Once perfected, the colored chip is computer-scanned in a special machine in order to archive the correct values. Our paints are computer-formulated, kept in files where we store the exact quantity of pigment and chemical composition for each color. Once the process begins to create a paint, the exact amount of each component is placed mechanically in a container. It is then well-mixed for an extended period of time, until the complete mix has certain kind of texture and color uniformity depending on the formula used.

En AK Interactive, queremos mostraros como se crean las pinturas en nuestra fábrica. El proceso previo es más complicado, ya que los colores tienen que ser probados una y otra vez hasta que conseguimos el tono correcto y exacto, entonces se escanea la placa de pintura en un escaner especial de colorimetría para guardar los valores correctos.

Nuestras pinturas una vez almacenadas en el ordenador, se guardan en archivos que contienen la fórmula exacta de pigmentos y componentes para su fabricación. Una vez el proceso empieza, la cantidad exacta de pigmento y componentes se une de manera automática en un contenedor. Se mezcla bien durante un periodo largo, hasta que la mezcla tiene la textura y uniformidad de color adecuadas, dependiendo de la fórmula utilizada.

Now it comes the time to fill the bottle or jars. This process has to be controlled carefully because any issue could cause the paint to vary in color. Here we can see our qualified staff looking after the whole process of bottling and placing the lids.

Ahora viene el momento de llenar las botellas, este proceso tiene que controlarse cuidadosamente porque cualquier problema puede hacer variar el tono de la pintura. Aquí podemos observar a nuestro personal cualificado cuidando que no haya problemas en el embotellado y colocando los tapones.

LABELLING / ETIQUETADO

Once the previous step is complete, all bottles that have passed quality control are ready for labelling. Here, the correct labels with the reference number and barcode are affixed to the jars.

Una vez el proceso anterior termina y todas las botellas han pasado el control de calidad, están listas para etiquetar, aquí las etiquetas adecuadas impresas previamente con su referencia y código de barras se pegan a las botellas.

ANOTHER QUALITY TEST / OTRO TEST DE CALIDAD

To make sure our products have the best quality we make a random quality test over every batch. We take one of the jars from each batch and test its consistency using both brush and airbrush. For all those products which are not acrylics, the process is the same but may require further testing over plastic painted pieces or similar.

Para estar seguros que nuestros productos tienen la mejor calidad hacemos un control aleatorio sobre cada lote. Elegimos una botella por cada lote y probamos su consistencia a pincel y aerógrafo. Esto ocurre de igual manera para aquellos productos que no son acrílicos, el proceso es el mismo pero alguno requieren pruebas más profundas en plástico u otros materiales.

STOCKING AND BOXING / ALMACENAJE

Once all quality processes have been completed and we are satisfied with the result, it's now time to stock them properly and get them ready so they can arrive in perfect condition at your home.

Una vez todos los procesos de calidad han terminado y estamos satisfechos con el resultado, es el momento de almacenarlas correctamente y prepararlas para que estén listas para su envío.



2

AKRYLICS / AKRÍLICOS 2.1 AKRYLIC PAINTS / PINTURAS AKRÍLICAS

3rd GENERATION ACRYLICS ?

WHAT DOES THIS MEAN???

¿QUÉ SIGNIFICA ESTO?

We have evolved and revolutionized the rules that governed acrylic paints, allowing us to present the third generation acrylics at the service of the world of scale modeling and fine arts. These paints feature high opacity and pigmentation, and they are specially formulated to be applied by brush and airbrush to scale models and miniatures made of resin, plastic or metal.

We needed to improve the acrylic paints available on the market thus far:

Acrylic colors have been widely used by modelers. They have great advantages such as the absence of toxicity, but these paints have not yet been able to offer comprehensive functionality due to grip deficiencies, clogging in the tip of the airbrush or coverage problems. We took on the challenge of maintaining their advantages, solving their issues and improving their characteristics. Now you have the solution. After a long time developing and perfecting new formulas in the laboratory we wanted to show you the results. **Painting with acrylics will no longer be the same ...**

Hemos evolucionado y revolucionado las normas que regían las pinturas acrílicas y os presentamos el acrílico de tercera generación al servicio del mundo del modelismo y las bellas artes. Estas pinturas poseen una alta opacidad y pigmentación y están especialmente formuladas para ser aplicadas a pincel y aerógrafo en maquetas y miniaturas de resina, plástico o metal.

Necesitábamos mejorar los acrílicos del mercado:

Los colores acrílicos han sido ampliamente utilizados por los modelistas. Presentan grandes ventajas como la ausencia de toxicidad, pero son pinturas que no han podido ofrecer hasta ahora una funcionalidad integral al presentar deficiencias en cuanto a adherencia, atascos en la boquilla del aerógrafo o problemas de cobertura. Asumimos el reto de mantener las ventajas, resolver sus inconvenientes y mejorar sus características. Ahora ya tienes la solución, después de mucho tiempo desarrollando y perfeccionando nuevas fórmulas en el laboratorio queríamos mostrarte los resultados.

Pintar con acrílicos ya no va a ser lo mismo...



NEW FORMULA NUEVA FÓRMULA



New formula featuring high performance resins and high quality components. The paints are made in accordance with European regulations, thus ensuring that no harmful substances are used that could pose a risk to the health of the user and the environment. *Nueva fórmula con resinas de altas prestaciones y componentes de alta calidad. Las pinturas se elaboran conforme a la normativa Europea, garantizando así que no se empleen sustancias nocivas que podrían implicar un riesgo para la salud del usuario y del medioambiente.*

READY FOR BRUSH APPLICATION LISTOS PARA APLICARSE A PINCEL



The paint is prepared to be applied directly from the bottle by brush. Another of its advantages is the incorporation of special anti-decanters that prevent the separation of the paint components within the bottle. This allows the paints to be ready to use when you are, without the need for prolonged and exhausting bottle shaking to mix the contents. *La pintura está preparada para que puedas pintar directamente del envase a pincel, sin tener que cansarte agitando, ya que otra de sus ventajas es la incorporación de anti-decantantes, especiales que evitan la separación de los componentes de la pintura en el bote.*

GRIP ADHERENCIA



Once dry, the colors are permanent and waterproof. They are resistant to oils, enamels, washes, solvents or any potentially aggressive technique. They are easily applied without hiding the finest details of the figures or scale models. Our new formula offers adhesion and resistance up to twice as much as other paints in the market. *Una vez secos, los colores son permanentes e impermeables. Son resistentes a óleos, esmaltes, lavados, disolvente o cualquier técnica potencialmente agresiva. Se extienden fácilmente sin ocultar los detalles más finos de las figuras o maquetas. Nuestra nueva fórmula ofrece una adherencia y resistencia hasta dos veces superior a otras pinturas del mercado.*

NO CLOGGING SIN ATASCOS



Are you tired of experiencing clogging in the airbrush with acrylic paints, having cuts in the stroke or getting sandy paint? One of the advantages of the third generation formula is that we have solved these problems and improved the performance. *¿Estás cansado de tener atascos en el aerógrafo con las pinturas acrílicas, de tener cortes en el trazo o pintura arenosa? Una de las ventajas de la fórmula de tercera generación es que hemos solventado estos problemas y mejorado las prestaciones.*

HIGH COVERAGE ALTA COBERTURA



High opacity and water-based pigmentation that overcome any other product in the market. Current paints contain cellulose and resins that cause them, even when diluted, not cover or clog in the airbrush. We have created a new formula for brush and airbrush painting avoiding this this problem while also providing short drying times, a short drying time, a matt finish and an intense tone. *Alta opacidad y pigmentación con base agua que supera cualquier otro producto en el mercado. Las pinturas actuales contienen celulosa y resinas que hacen que, incluso siendo diluidas, no cubran o se atasquen en el aerógrafo. Hemos creado una nueva fórmula para pintar a pincel y aerógrafo evitando este problema, consiguiendo un rápido secado, un acabado mate y un tono intenso.*

INNOVATIVE DESIGN DISEÑO INNOVADOR



It comes in a 17ml bottle with dropper and its weight is 35gr. The patented design of the cap cap provides a recess for a small deposit of paint to see the exact tone in vertical position, allowing a fast and exact identification. *Se presenta en un frasco de 17ml. con cuentagotas y su peso es de 35gr. El diseño patentado del tapón permite depositar pintura y ver el tono exacto en posición vertical permitiendo una rápida y exacta identificación.*

WIDEST RANGE LA GAMA MÁS AMPLIA



356 state-of-the-art colors, the most extensive range in the market for acrylic colors in which you will find a solution whatever your speciality is. Made with a technologically superior formula for painting with a brush or an airbrush. No toxic elements, very high pigmentation, ideal for scale models, miniatures and modeling in general. *356 colores de última generación, la gama más extensa del mercado para unos colores acrílicos en los que encontrarás solución sea cual sea tu especialidad. Elaborados con una fórmula tecnológicamente superior para pintar con pincel o aerógrafo. Sin elementos tóxicos, de muy alta pigmentación, ideal para maquetas, miniaturas y modelismo en general.*

WHAT ELSE CAN YOU EXPECT ?

¿QUÉ MÁS PUEDES ESPERAR?

The first thing you are going to see is a bottle with the AK logo identifying the product and a characteristic white cap with a recess on its top that allows to deposit paint and achieve a fast and precise identification of the color.

Our team of modelers assumed the role of final consumers, they tested the product they identified the characteristics that would be most required by the users and that they would expect from the paint themselves.

The quick drying and the comfort of having an acrylic product with a perfect matte finish could be improved in terms of usability if the brush strokes were not perceived, provided a perfect covering and if they could also be applied with an airbrush with the same ease as the enamel based paints.

Lo primero que vas a ver es un envase con el logo de AK en el fondo identificando el producto y un tapón blanco característico con un depósito en su parte superior que permite depositar pintura y lograr una rápida y precisa identificación del color.

Nuestro equipo de modelistas asumieron el rol de consumidor final, probaron el producto hasta identificar las características que necesitan los usuarios y que a ellos mismos les gustaría encontrar en una pintura.

El secado rápido y la comodidad de tener un producto acrílico con un acabado mate perfecto se podía mejorar en cuanto a usabilidad si los trazos del pincel no se percibiesen, proporcionasen una perfecta cobertura, y que además se pudiesen aplicar con aerógrafo con la misma facilidad que las pinturas de base esmalte.

Original trademark at the bottom of the bottle.
Marca original en la parte inferior del bote.



Use the top hole featuring an eyedropper to deposit the paint.

Usar el orificio superior del cuentagotas para depositar la pintura.

Apply some drops in the top hole of the cap.

Aplicar unas gotas en el orificio del tapón.

Patented cap, easy opening, neutral color to make visible any kind of paint.

Tapón patentado, fácil apertura, color neutro para hacer visible cualquier tipo de pintura.

Remove the cap.
Quitar el tapón.

1



2



3

Distribute properly and let dry.
Distribuirlo apropiadamente y dejar secar.



4

Ready to always identify your color.
Listo para identificar siempre su color.

5



TYPES OF ACRYLIC PAINTS TIPOS DE PINTURAS ACRÍLICAS



ORANGE LABEL ETIQUETA NARANJA

The basic label. The orange dot is the element that remarks a range of colors designed for any kind of modeler. The clear and easily identifiable label includes the name of the color and its reference code at the top.

La etiqueta general. El punto naranja es el elemento que destaca en un rango de colores diseñados para cualquier tipo de modelista. La etiqueta clara y fácilmente identificable, incluye el nombre del color y su referencia en la parte superior.



CYAN LABEL ETIQUETA CIAN

There are 6 pastel colors within the range, which are identified by a pastel blue circle. These tones can be used, as the others, in any type of modeling, figures, sceneries, buildings, vehicles...

Existen 6 colores pastel dentro de la gama, los cuales están identificados con un círculo azul pastel. Estos tonos pueden ser utilizados, como el resto, en cualquier rama de modelismo, figuras, escenarios, edificios, vehículos...



BLUE LABEL ETIQUETA AZUL

The range contains a selection of 22 metallic tones with ultrafine pigmentation, marked by the label featuring a dark blue circle.

La gama contiene una selección de 22 tonos metálicos con pigmentación ultrafina identificados por las etiquetas que contienen un círculo azul oscuro.



GREY LABEL ETIQUETA GRIS

The bottles identified by labels with a grey circle comprise specially formulated mediums to modify the properties of paints. Glaze Medium dilutes the paints and extends their drying time allowing to make glazes or mixtures. Metallic Medium mixed with other paints offers a pearly and metallic effect. Crackle Medium causes the paint to crack, whilst the Chipping Medium, applied between two layers of paint, enables to create chipping effects on the top surface color.

Los envases identificados con etiquetas con el círculo gris comprenden Mediums especialmente formulados para modificar las propiedades de las pinturas. Glaze Medium diluye los colores y extiende su tiempo de secado para efectuar veladuras o mezclas. Metallic Medium mezclado con los colores ofrece un efecto nacarado y metalizado. Con el Medium de Craquelar se consigue el cuarteado de la pintura y con el Chipping Medium, aplicado entre dos capas de pintura, se logra el desconchado del color superficial.



YELLOW LABEL ETIQUETA AMARILLA

Intense colors are identified with the yellow circle on the label. These tones contain pigments of high purity and high concentration for the most vivid colors.

Los colores intensos están identificados con el círculo amarillo en la etiqueta. Estos tonos contienen pigmentos de gran pureza y alta concentración para los colores más vivos.



BROWN LABEL ETIQUETA MARRÓN

The general label to identify the inks is the one with a brown circle. The inks of this range are not standard ones, the balance between fluidity and intensity allows to carry out the most challenging works. The selection of tones is ideal for working on most of the possible tones.

La etiqueta general para identificar las tintas es la que tiene un círculo marrón. Las tintas de esta gama no son unas tintas al uso, el equilibrio entre la fluidez y la intensidad permite llevar a buen puerto los trabajos más complicados. La selección de tonos es ideal para trabajar sobre la mayor parte de tonos posibles.



AFV LABEL ETIQUETA VEHÍCULOS MILITARES

The AFV label identifies specific colors for painting military vehicles from all eras. Very special tones used by different armies in different periods (FS, RAL, etc.).

La etiqueta AFV contiene colores específicos para pintar vehículos militares de todas las épocas. Tonos muy especiales utilizados para diferentes ejércitos en diferentes periodos (FS, RAL, etc.).



FIGURE LABEL ETIQUETA SERIE FIGURAS

The range with figure label is a compilation of very specific colors used for painting historical figures, including WWI, WWII and modern uniform tones that are not included in other series.

La etiqueta para figuras es una recopilación de colores muy específicos utilizados para pintar figuras históricas, segunda guerra mundial y uniformes modernos en tonos que no se incluyen en el resto de etiquetas.



AIR SERIES LABEL ETIQUETA SERIE PARA AVIONES

Another formula was developed for our AIR series. These paints have the correct opacity and produce a perfect satin finish. We offer a wide range of colors that are useful for painting models of aircraft from many countries and different periods, from World War One until today.

Otra fórmula fue desarrollada para nuestra serie AIR. Estas pinturas tienen la opacidad correcta para aviación y producen un acabado satinado perfecto. Ofrecemos una amplia gama de colores que son útiles para pintar modelos de aeronaves de muchos países y diferentes periodos, desde la Primera Guerra Mundial hasta nuestros días.

2.2 GENERIC SETS /SETS GENERICOS



AK11600

ORCS AND GREEN CREATURES

Included / Incluye: AK11133 Dark Green Grey, AK11146 Dark Green, AK11142 Deep Green, AK11141 Light Green, AK11147 Olive Green, AK11139 Golden Olive



AK11601

NMM STEEL

Included / Incluye: AK11001 White, AK11029 Black, AK11006 Silver Grey, AK11019 Graphite, AK11167 Anthracite Grey, AK11173 Ocean Blue

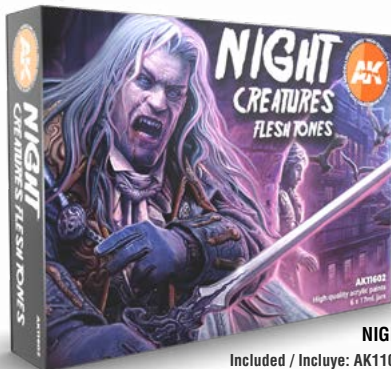

AK11602

NIGHT CREATURES FLESH TONE

Included / Incluye: AK11002 Offwhite, AK11026 Tenebrous Grey, AK11057 Vampiric Flesh, AK11067 Magenta, AK11074 Deep Purple, AK11095 Dirty Red



AK11603

HUMAN FLESH TONES

Included / Incluye: AK11064 Beige Red, AK11055 Sunny Skin Tone, AK11052 Basic Skin Tone, AK11098 Black Red, AK11075 Violet Red, AK11096 Wine Red



AK11604

INFERNO AND RED CREATURES

Included / Incluye: AK11092 Matt Red, AK11088 Deep Red, AK11085 Cadmium Red, AK11077 Light Orange, AK11042 Volcanic Yellow, AK11097 Burnt Red.



AK11606

NMM GOLD

Included / Incluye: AK11004 Ivory, AK11035 Sand Yellow, AK11036 Ice Yellow, AK11040 Sahara Yellow, AK11073 Purple, AK11108 Hull Red



AK11607

PASTELS

Included / Incluye: AK11037 Pastel Yellow, AK11059 Pastel Pink, AK11069 Pastel Violet, AK11076 Pastel Peach, AK11131 Pastel Green, AK11168 Pastel Blue



AK11608

METALLICS

Included / Incluye: AK11192 Gold, AK111194 Brass, AK11197 Copper, AK11209 Silver, AK11210 Natural Steel, AK11212 Gun Metal



AK11609

WHITE

Included / Include: AK11001 White, AK11002 Offwhite, AK11006 Silver Grey, AK11009 Warm Grey, AK11017 Reddish Grey, AK11021 Basalt Grey



AK11610

NEON

Included / Include: AK11049 Fluorescent Yellow, AK11068 Fluorescent Magenta, AK11081 Fluorescent Orange, AK11082 Luminous Orange, AK11129 Fluorescent Green, AK11178 Fluorescent Blue



AK11612

INTENSE

Included / Include: AK11045 Deep Yellow, AK11080 Deep Orange, AK11088 Deep Red, AK11074 Deep Purple, AK11142 Deep Green, AK11182 Deep Blue

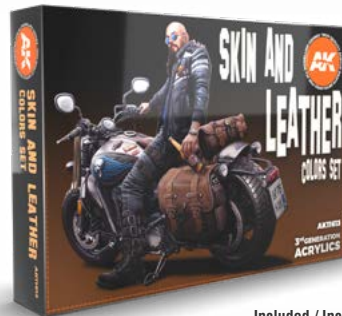

AK11613

SKIN AND LEATHER

Included / Include: AK11026 Tenebrous Grey, AK11078 Medium Orange, AK11102 Deep Brown, AK11110 Leather Brown, AK11115 Light Earth, AK11118 Ochre



AK11614

GREY SPACESHIPS

Included / Include: AK11013 Pale Grey, AK11008 Grimy Grey, AK11012 Sky Grey, AK11015 Dark Sea Grey, AK11016 Grey-Green, AK11018 Neutral Grey



AK11605

RUST RUST & ABANDONED

Included / Include: AK11101 Orange Brown, AK11103 Medium Rust, AK11105 Light Rust, AK11107 Dark Rust, AK11108 Hull Red, AK11113 Chocolate (Chipping)

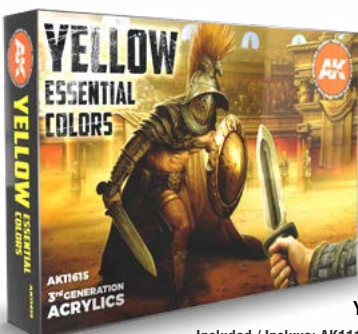

AK11615

YELLOW ESSENTIAL COLORS

Included / Include: AK11100 Light Brown, AK11117 Golden Brown, AK11042 Volcanic Yellow, AK11044 Yellow, AK11035 Sand Yellow, AK11038 Pale Yellow



AK11618

BLUE ESSENTIAL COLORS

Included / Include: AK11165 Grey-Blue, AK11172 Archaic Turquoise, AK11175 Sky Blue, AK11177 Ducat Blue, AK11431 Russian Blue Lights, AK11432 Russian Blue Base



AK11673

OLD & WEATHERED WOOD VOL.1

Included / Include: AK11115 Freshly Cut Timber, AK11351 Wood Base, AK11106 Dark Wood Grain, AK11108 Wood Grain, AK11119 Varnished Wood, AK11110 Weathered Wood



AK11674

OLD & WEATHERED WOOD VOL.2

Included / Include: AK11007 Light Grey, AK11013 Middle Grey, AK11008 Light Grey Brown, AK11009 Medium Grey, AK11127 Medium Brown, AK11111 Burnt Umber

2.3 AFV SERIES / SERIE DE VEHÍCULOS ARMADOS

Under the AFV Series label, we bring you numerous AKrylic sets intended for painting military vehicles from various countries and different eras, ranging from World War One, until today. This includes both paint designed for simple and fast application of the modulation technique, without the need for mixing different shades on your own, and also the correct colors matching the popular standards (FS, RAL, etc.), which are scaled for the best results.

Bajo la etiqueta de la Serie AFV, te traemos numerosos sets de AKrylicos para pintar vehículos militares de varios países y diferentes épocas, desde la Primera Guerra Mundial hasta la actualidad. Esto incluye la pintura diseñada para una aplicación simple y rápida de la técnica de modulación, sin la necesidad de mezclar diferentes tonos por su cuenta, y también los colores correctos que coinciden con los estándares populares (FS, RAL, etc.), que se escalan para el mejor resultado.



AK11639 480 RUSSIAN GREEN MOD

Included / Incluye: AK11153 Extra Dark Green, AK11159 Russian Green, AK11368 Russian Green 4bo, AK11374 Silver Grey N°28

Set of 3rd Generation acrylic paints intended for finishing vehicles painted in 480 Russian Green.

Set de 4 pinturas acrílicas 3Gen para vehículos pintados en verde ruso 480.



AK11640 GERMAN DUNKELGELB MOD

Included / Incluye: AK11111 Burnt Umber, AK11124 Middle Stone, AK11318 Dunkelgelb Initial, AK11037 Pastel Yellow

Set of 3rd Generation acrylic paints intended for finishing vehicles painted in the famous German Dunkelgelb (Dark Yellow)

Set de 4 pinturas acrílicas 3Gen para vehículos alemanes originales pintados en el famoso amarillo oscuro (Dunkelgelb).



AK11641 GERMAN RED PRIMER MOD

Included / Incluye: AK11108 Hull Red, AK11106 Mahogany Brown, AK11102 Deep Brown, AK11100 Light Brown

Set of 3rd Generation acrylic paints intended for finishing vehicles painted in the famous German red primer.

Set de 4 pinturas acrílicas 3Gen para vehículos originales alemanes en fábricas o prototipos utilizados para pruebas.



AK11642 GERMAN PANZER GREY MOD

Included / Incluye: AK11026 Tenebrous Grey, AK11024 Ash Grey, AK11019 Graphite, AK11010 Medium Grey

Set of 3rd Generation acrylic paints intended for finishing vehicles painted in the famous German Panzer Grey (Dunkelgrau)

Set de 4 pinturas acrílicas 3Gen para vehículos alemanes pintados en el famoso Panzer Grey (Dunkelgrau).



AK11643 US OLIVE DRAB MOD

Included / Incluye: AK11339 N°9 Olive Drab, AK11334 Olive Drab, AK11151 Brownish Green, AK11345 APC Interior Light Green

Set of 3rd Generation acrylic paints intended for finishing Allied vehicles painted in US Olive Drab.

Set de 4 pinturas acrílicas 3Gen para vehículos estadounidenses en la Segunda Guerra Mundial pintados en verde oliva.



AK11644 WWI BRITISH COLORS MOD

Included / Incluye: AK11111 Burnt Umber, AK11301WWI British Khaki Brown, AK11122 Green Ochre, AK11115 Light Earth

Set of 3rd Generation acrylic paints intended for finishing British tanks from WW1 period painted in Khaki Brown.

Set de 4 pinturas acrílicas 3Gen para replicar el aspecto marrón típico de la mayoría de los tanques británicos en 1917 y 1918.



**AK11645
GERMAN STANDARD
37-43 COMBO**

Included / Incluye: AK11315 RAL 7017 Dunkelbraun, AK11316 RAL 7021 Dunkelbraun, AK11372 Washable White Paint

Set of 3rd Generation acrylic paints including the three basic camouflage colors used for painting German army vehicles in the 1937-43 period
Una combinación de pinturas acrílicas 3Gen en un set especial, que contiene los colores más comunes de los vehículos del ejército alemán utilizados entre 1937 y 1943.



**AK11646
BRITISH DESERT COLOURS 1940-43**

Included / Incluye: AK11374 Silver Grey No.28, AK11375 Slate No.34, AK11377 Light Stone No.61, AK11378 Portland Stone No.64, AK11381 Dark Olive Green PFI, AK11382 Desert Pink ZI

A 3rd Generation acrylic paint set featuring the six basic camouflage colors used for painting vehicles of British and Commonwealth forces deployed in North Africa and the Mediterranean from mid-1940 to the spring of 1943.
British Desert Colors 1940-43, es un set de seis pinturas 3Gen para pintar los vehículos británicos utilizados en las campañas de Europa y África durante este periodo.



**AK11647
VEHICLE & TANK ACCESSORIES**

Included / Incluye: AK11194 Brass, AK11092 Matt Red, AK11190 Dark Sea Blue, AK11109 Dark Brown, AK11031 Buff, AK11212 Gun Metal

A 3rd Generation acrylic paint set including six colors indispensable for painting details, equipment, ammunition and other accessories carried by tanks and other military vehicles.
Set de seis pinturas acrílicas de 3Gen que contienen los colores necesarios para pintar equipos, municiones y otros accesorios comunes transportados por vehículos de combate de forma habitual.



**AK11648
MIDDLE EAST WAR COLORS**

Included / Incluye: AK11352 IDF Modern Grey, AK11353 IDF Sand Grey 1970s-1980s, AK11354 IDF Early Sand Yellow, AK11355 IDF Green, AK11356 SLA Blue, AK11357 LAF Green

A 3rd Generation acrylic paint set featuring six camouflage colors indispensable for painting models of vehicles participating in the Middle East Wars.
Set de seis pinturas acrílicas 3Gen que incluyen los colores IDF Sand Grey y Early Dark Yellow, exactamente como los utilizados en los vehículos reales de las IDF, o el característico verde IDF de los primeros períodos.



**AK11649
AUSCAM COLORS**

Included / Incluye: AK11348 Australian Camouflage Green, AK11347 Australian Camouflage Brown, AK11028 Smoke Black

This 3rd Generation acrylic paint set offers the modeler the three colors essential for painting the AUSCAM disruptive camouflage pattern, used by the Australian Army since the early 1990s.
Este set 3Gen ofrece al modelista los tres colores esenciales para pintar el esquema de camuflaje de patrón disruptivo AUSCAM, utilizado desde principios de la década de 1990.



**AK11650
IDF AFV COLORS**

Included / Incluye: AK11352 IDF Modern Grey, AK11353 IDF Sand Grey 1970s-1980s, AK11354 IDF Early Sand Yellow

This 3rd Generation acrylic paint set contains the three standard colors used for painting the Israeli Defence Forces vehicles from its foundation until today.
Este set 3Gen ofrece al modelista los tres colores esenciales para pintar vehículos de las IDF con colores correctos para diferentes épocas. Exactamente como los utilizados en vehículos reales de las IDF.

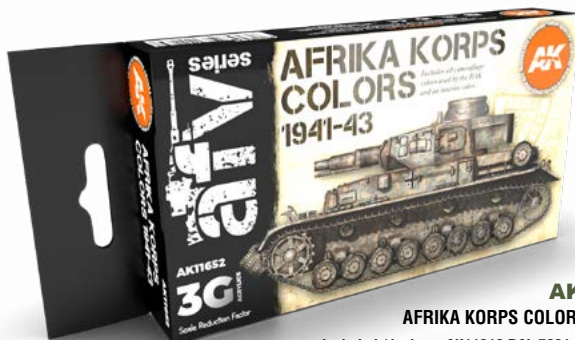

**AK11652
AFRIKA KORPS COLORS 1941-43**

Included / Incluye: AK11316 RAL 7021 Dunkelgrau, AK11313 RAL 7008 Graugrün, AK11327 RAL 8000 Gelbbraun, AK11317 RAL 7027 Grau, AK11331 RAL 8020 Braun, AK11333 RAL 1001 Elfenbein

A 3rd Generation acrylic paint set featuring six colors used for painting vehicles of the German Afrika Korps in North Africa from early 1941 to May 1943.
Set de 6 pinturas acrílicas 3Gen para vehículos alemanes Deutsche Afrika Korps en el norte de África desde principios de 1941 hasta mayo de 1943.



**AK11653
MERDC CAMOUFLAGE COLORS**

Included / Incluye: AK11342 Dark Green, AK11335 Light Green, AK11343 MERDC Sand, AK11344 Field Drab, AK11337 Earth Yellow, AK11346 Forest Green, AK11338 Earth Red, AK11001 White

A 3rd Generation acrylic paint set featuring the eight colors that are essential for reproducing MERDC camouflage patterns applied to US Army vehicles from the mid-1970s to the mid-1980s.
Este set 3Gen contiene los colores necesarios para pintar vehículos estadounidenses de acuerdo con el sistema de camuflaje MERDC utilizado por el Ejército de los Estados Unidos durante la década de 1970.



AK11654

1945 PANZER COLORS

Included / Incluye: AK11318 RAL 7028 Dunkelgelb, AK11319 RAL7028 Dunkelgelb 1944, AK11309 RAL 6003 Olivgrün, AK11328 RAL 8012 Rotbraun, AK11330 RAL 8017 Rotbraun, AK11372 Washable White Paint

A 3rd Generation acrylic paint set featuring the six colors that are indispensable for painting models of German Army vehicles from the last months of World War II. A finales de 1944, el ejército alemán presentó una nueva normativa y nuevas variantes en los colores utilizados para la pintura de sus vehículos. Con este set 3Gen los modelistas podrán pintar los tanques alemanes de final de guerra.

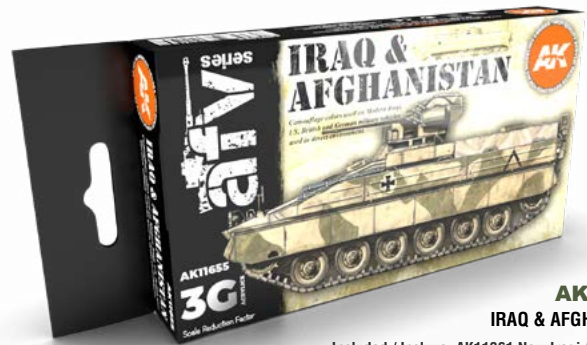

AK11655

IRAQ & AFGHANISTAN

Included / Incluye: AK11361 New Iraqi Army Sand, AK11362 British Sand Yellow, AK11349 CARC Tan 686A, AK11326 RAL 8031 F9 Sandbraun, AK11325 RAL 1039 F9 Sandbeige, AK11323 RAL 6040 F9 HelloIv

A 3rd Generation acrylic paint set including six camouflage colors used for painting Modern Iraqi, U.S., British and German vehicles employed in desert environment of Iraq or Afghanistan. Este set de seis colores 3Gen permite pintar los esquemas de pintura de los vehículos desplegados en Afganistán e Irak. Década de 1970.



AK11656

1937-44 PANZER COLORS

Included / Incluye: AK11315 RAL 7017 Dunkelbraun, AK11316 RAL 7021 Dunkelgrau, AK11318 RAL 7028 Dunkelgelb, AK11309 RAL 6003 Olivgrün Opt.1, AK11310 RAL 6003 Olivegrün Opt.2, AK11330 RAL 8017 Rotbraun

A 3rd Generation acrylic paint set featuring the six colors essential for painting models of German Army vehicles used in Europe from 1937 until 1944. El ejército alemán utilizó varias ordenanzas para camuflar sus vehículos durante la Segunda Guerra Mundial.



AK11657

WWII SOVIET TANK COLORS

Included / Incluye: AK11368 Russian Green 4bo, AK11369 Russian Dark Brown 6K, AK11370 Russian Sand 7K, AK113687 3B AU/ZB AU, AK11371 Protective Green 1920s-1930s, AK11372 Washable White Paint

A 3rd Generation acrylic paint set featuring the six colors essential for painting models of Soviet Army vehicles used during World War II. Este set de pintura acrílica 3Gen ha sido diseñado para reproducir los colores utilizados por los vehículos del Ejército Rojo durante el período 1935-1945.



AK11658

NATO COLORS

Included / Incluye: AK11358 Nato Green, AK11359 Nato Brown, AK11360 Nato Black

This 3rd Generation acrylic paint set contains the three standard colors used for painting military vehicles and equipment of the armies of most of the NATO member states from the second half of the 1980s.

Los tres colores de este set 3Gen permiten recrear los vehículos utilizados por las tropas de la OTAN, desplegadas en todo el mundo.



AK11659

VIETNAM COLORS

Included / Incluye: AK11157 US Army Olive Drab, AK11345 APC Interior Light Green, AK11153 Extra Dark Green

This 3rd Generation set contains the three colors essential for painting models of vehicles used by the US Army and US Marine Corps during the Vietnam War. Los tres colores de este set 3Gen permiten recrear el camuflaje de los vehículos utilizados por el Ejército de los EE. UU. y el USMC durante la Guerra de Vietnam.



AK11660

WWI FRENCH AFV COLORS

Included / Incluye: AK11302 WWI French Milky Coffee, AK11303 Artillery Grey, AK11162 Spectrum Blue, AK11304 WWI French Brown, AK11305 WWI French Green #1, AK11306 WWI French Green #2

This 3rd Generation acrylic paint set offers the modeler the six colors essential for painting tanks and artillery pieces of the French Army during the Great War. Este set 3Gen ofrece al modelista los seis colores más comunes utilizados por tanques y unidades de artillería del ejército francés durante la Gran Guerra.



AK11661

MODERN FRENCH ARMY COLORS

Included / Incluye: AK11358 Nato Green, AK11359 Nato Brown, AK11360 Nato Black, AK11363 French Army Desert Sand, AK11364 French Army Green, AK11365 French Army Grey-Blue

A 3rd Generation acrylic paint set featuring the six colors essential for painting models of French Army vehicles used from the 1950s until today. Este set de seis pinturas acrílicas 3Gen es imprescindible para pintar los vehículos utilizados por el ejército francés desde los años 50 hasta la actualidad.



AK11662

MODERN RUSSIAN COLORS VOL 1

Included / Incluye: AK11028 Smoke Black, AK11008 Grimy Grey, AK11366 Mustard Yellow, AK11013 Pale Grey, AK11158 Reflective Green, AK11367 Base Green

This 3rd Generation acrylic paint set offers the modeler the six colors that are essential for replicating the camouflage patterns which are most commonly applied to vehicles of the Russian Army and armed forces of many of the post-Soviet states.

Este set ofrece al modelista los seis colores 3Gen esenciales para replicar los patrones de camuflaje más habituales de los vehículos del ejército ruso y las fuerzas armadas de muchos de los estados ex-soviéticos.



AK11663

MODERN RUSSIAN COLORS VOL 2

Included / Incluye: AK114032 Pale Sand, AK11101 Orange Brown, AK11108 Hull Red, AK11147 Olive Green, AK11165 Grey Blue, AK11159 Russian Green

This 3rd Generation acrylic paint set is not only an add-on for the first Modern Russian Colors set, with additional colors allowing for reproduction of even more camouflage patterns, but it also offers the three colors indispensable for recreating the attractive hard-edge camouflage scheme recently applied to many modern Russian vehicles.

Este set 3Gen no solo es el complemento perfecto del primer set, con colores adicionales para reproducir aún más patrones de camuflaje, sino que también incluye los tres colores indispensables para recrear el atractivo esquema de camuflaje de borde duro aplicado a muchos vehículos rusos recientemente.



AK11664

GERMAN STANDARD COLORS 1943-45

Included / Incluye: AK11318 RAL 7028 Dunkelgelb, AK11309 RAL 6003 Olivgrün, AK11330 RAL 8017 Rotbraun

A special set of 3rd Generation acrylic paints including the three basic camouflage colors used for painting German army vehicles from the spring of 1943 until the end of the World War II.

Una combinación de 3 pinturas acrílicas 3Gen en un set que contiene los colores típicos de los vehículos del ejército alemán utilizados entre 1943 y 1945.



AK11665

WWII RUSSIAN STANDARD COLORS

Included / Incluye: AK11368 Russian Green 4b, AK11369 Russian Dark Brown 6K, AK11370 Russian Sand 7K

A special set of 3rd Generation acrylic paints including the three basic camouflage colors used for painting Soviet army vehicles during World War II.

Una combinación de pinturas acrílicas 3Gen en un set que contiene los colores comunes para pintar la mayoría de los tanques soviéticos de la Segunda Guerra Mundial.



AK11666

BUNDESWEHR DESERT COLORS

Included / Incluye: AK11326 RAL 8030 F9 Sandbraun, AK11325 RAL 1039 F9 Sanbeige, AK11323 RAL 6040 F9 Helloliv

Set of 3rd Generation acrylic paints including the three camouflage colors that are most commonly used for painting Bundeswehr vehicles used in the desert environment, such as those belonging to the German ISAF contingent in Afghanistan.

Una combinación de pinturas acrílicas en un set de 3Gen que contiene los colores para pintar los tanques modernos alemanes en sus variantes de camuflaje del desierto. EE.UU. y el USMC durante la Guerra de Vietnam.



AK11668

WWII US ARMY & USMC CAMOUFLAGE COLORS

Included / Incluye: AK11355 N°1 Light Green, AK11336 N°5 Earth Brown, AK11337 N°6 Earth Yellow, AK11338 N°8 Earth Red, AK11339 N°9 Olive Drab, AK11340 N°13 Desert Sand, AK11341 Ocean Gray, AK11029 Black

A 3rd Generation acrylic paint set featuring the eight colors that are essential for painting models of US Army and US Marine Corps vehicles used during World War II.

Este set 3Gen contiene los ocho colores principales utilizados por el Ejército de los Estados Unidos y la Infantería de Marina durante la Segunda Guerra Mundial.



AK11669

1946 PANZER COLORS

Included / Incluye: AK11320 RAL 7028 Dunkelgelb, AK11311 RAL 6011 Resedagrün, AK11312 RAL 6011B Resedagrün, AK11328 RAL 8012 Rotbraun

Set of 3rd Generation acrylic paints including the four camouflage colors that could be used for painting German army vehicles if the war continued. A must have for all fans of Panzerwaffe 1946 and what-if camouflage schemes!

Este set 3Gen se ha desarrollado teniendo en cuenta los modelos What-if para representar los colores de los vehículos del ejército alemán, utilizados en 1946.



AK11675

US TANK COLORS EUROPE 1944-45

Included / Incluye: AK11339 N°9 Olive Drab, AK11029 Black, AK11372 Washable White Paint

Set of 3rd Generation acrylic paints including the three basic camouflage colors used for painting US Army vehicles operating in Europe from the invasion of Normandy until the fall of the Third Reich.

Los patrones más comunes utilizados por los vehículos estadounidenses en Europa en el periodo 1944-45 son posibles con este set de tres colores 3Gen.



AK11676
BRITISH CAUNTER SCHEME 1940-1941
 Included / Incluye: AK11374 Silver Grey No.28, AK11375 Slate No.34, AK11377 Light Stone No.61, AK11378 Portland Stone No.64
 Set of 3rd Generation acrylic paints including the four camouflage colors used for painting vehicles of British and Commonwealth forces deployed in North Africa and the Mediterranean, which were finished in the so-called Caunter Scheme employed from July 1940 until October 1941.
 El Esquema Caunter 1940-41, es un set de cuatro pinturas acrílicas 3Gen esenciales para pintar los vehículos británicos utilizados en las campañas de África y el Mediterráneo durante este período.



AK11677
BRITISH ARMY COLORS TUNISIA, SICILY & ITALY 1943-45
 Included / Incluye: AK11383 British Light Mud, AK11028 Smoke Black, AK11386 S.C.C. No.15 Olive Drab
 Set of 3rd Generation acrylic paints including the three camouflage colors that were most commonly used for painting vehicles of British and Commonwealth forces deployed in Tunisia, Sicily and Italy from April 1943 (S.C.C. No.15 Olive Drab was introduced one year later) until the end of World War II.
 Set de tres pinturas acrílicas 3Gen imprescindibles para pintar los vehículos británicos utilizados en Túnez, Sicilia e Italia durante las campañas en este período. Estos colores fueron usados por los ejércitos Canadiense, Australiano, Neozelandés y otros durante la misma época.



AK11678
BRITISH ARMY COLORS AFRICA, LATE 1942-43
 Included / Incluye: AK11377 Light Stone No.61, AK11381 Dark Olive Green PFI, AK11382 Desert Pink ZI, AK11028 Smoke Black
 Set of 3rd Generation acrylic paints including the four camouflage colors that were most commonly used for painting vehicles of British and Commonwealth forces deployed in North Africa from the autumn of 1942 until the spring of 1943.
 Set de cuatro pinturas de 3Gen para pintar los vehículos británicos utilizados en la campaña de África durante este el periodo 42-43. Estos colores fueron usados por los ejércitos Canadiense, Australiano, Neozelandés y otros durante la misma época.



AK11679
BRITISH ARMY COLORS NORTH-WEST EUROPE 1944-45
 Included / Incluye: AK11386 S.C.C. No.15 Olive Drab, AK11384 S.C.C. No.1A Very Dark Brown, AK11372 Washable White Paint, AK11028 Smoke Black
 Set of 3rd Generation acrylic paints including the four camouflage colors that were most commonly used for painting vehicles of British and Commonwealth forces deployed in the North-West Europe from 1944 until the end of World War II.
 Este set 3Gen incluye los colores más comunes utilizados por el ejército británico en el noroeste de Europa durante el periodo 1944-45. Estos colores fueron usados por los ejércitos Canadiense, Australiano, Neozelandés y otros durante la misma época.



AK11680
BRITISH ARMY COLORS NORTH-WEST EUROPE 1941-44
 Included / Incluye: AK11373 Khaki Green No.3, AK11384 S.C.C. No.1A Very Dark Brown, AK11385 S.C.C. No.2 Brown, AK11028 Smoke Black
 Set of 3rd Generation acrylic paints including the four camouflage colors that were most commonly used for painting vehicles of British and Commonwealth forces deployed in the North-West Europe in the 1941-1944 period.
 Esta set de 3Gen incluye los colores más comunes utilizados por el ejército británico en el noroeste de Europa durante el periodo 1941-44. Estos colores fueron usados por los ejércitos Canadiense, Australiano, Neozelandés y otros durante la misma época.



AK11686
WWI GERMAN TANK COLORS
 Included / Incluye: AK11154 Field Grey, AK11031 Buff, AK11109 Dark Brown, AK11308 RAL 6007 Grün
 A special set of 3rd Generation acrylic paints including the four camouflage colors that were most commonly used for painting vehicles and artillery pieces of the German army during the Great War.
 Esta selección de colores 3Gen ofrece al modelista los cuatro tonos más comunes utilizados en los tanques y las unidades de artillería del ejército alemán durante la Gran Guerra. Con este set se pueden reproducir con precisión los coloridos esquemas de camuflaje utilizados en las bestias alemanas.



AK11687
German Army Pre-WWII Colors
 Included / Incluye: AK11308 RAL 6007 Grün, AK11031 Buff, AK11109 Dark Brown
 A special set of 3rd Generation acrylic paints including the three standard camouflage colors used for painting German army vehicles from April 1933 until July 1937.
 Esta selección especial de colores de 3Gen ofrece al modelista los tres tonos más comunes utilizados por los tanques alemanes de preguerra.



AK11688
WWII German Tank Interior Colors
 Included / Incluye: AK11333 Cremeweiss, AK11307 RAL 7009 Hellgrau, AK11328 RAL 8012 Rotbraun, AK11329 RAL 8013 Rotbraun
 A special set of 3rd Generation acrylic paints including the four basic colors used for painting German army vehicle interiors during World War II.
 Este set 3Gen incluye los colores necesarios y precisos para pintar los interiores de los vehículos alemanes de la Segunda Guerra Mundial.



**AK11672
TRACKS & WHEELS**

Included / Incluye: AK11029 Satin Black, AK11027 Rubber/Tires, AK11108 Rusty Tracks, AK11111 Dark Tracks, AK1057 Dust, 11058 Dry Light Mud.

The six colors included in this 3rd Generation acrylic paint set are specially designed to help the modeler in creating a realistic appearance for all types of wheels and tracks on vehicles.

Los seis colores incluidos en este set de pintura 3Gen están seleccionados específicamente para crear una apariencia realista en todo tipo de ruedas y orugas de cualquier vehículo.



AK11670

STANDARD TOOLS ALL ERAS

Included / Incluye: AK11351 Wood Base, AK11106 Dark Wood Grain, AK11212 Gun Metal

A special set of 3rd Generation acrylic paints including the three colors essential for painting tools carried by military or civil vehicles from all eras. Includes two colors intended for replicating wood effects and one for metal parts of the tools.

Una selección de pinturas acrílicas 3Gen en un set básico con los colores para pintar herramientas comunes como las transportadas por vehículos militares o civiles. Incluye 2 colores para madera/netas y partes metálicas.



atv series

2.4 AIR SERIES / SERIE DE AVIONES

The AIR Series offers you a wide range of colors that allow to paint models of aircraft used in many countries, in different eras, from World War One until today. These paints produce satin finish which is perfect for decal application.
 La serie AIR le ofrece una amplia gama de colores que le permiten pintar modelos de aviones utilizados en muchos países, en diferentes épocas, desde la Primera Guerra Mundial hasta nuestros días. Estas pinturas producen un acabado satinado resistente que es perfecto para la aplicación de calcas y otros efectos.



AK2001
LUFTWAFFE CAMOUFLAGES

Included / Incluye: AK2002 RLM 02, AK2003 RLM 65, AK2004 RLM 66, AK2005 RLM 70, AK2006 RLM 71, AK2007 RLM 74, AK2008 RLM 75, AK2009 RLM 76



AK2010
RAF CAMOUFLAGES

Included / Incluye: AK2011 RAF Dark Green, AK2012 RAF Dark Earth, AK2013 RAF Medium Sea Grey, AK2014 RAF Ocean Grey, AK2015 RAF Sky, AK2016 RAF Middle Stone, AK2017 RAF Azure Blue, AK2018 Aircraft Grey Green



AK2020
LUFTWAFFE CAMOUFLAGES SET 2

Included / Incluye: AK2021 RLM 72, AK2022 RLM 73, AK2023 RLM 78, AK2024 RLM 79, AK2025 RLM 80, AK2026 RLM 81, AK2027 RLM 82, AK2028 RLM 83



AK2050
U.S. MODERN AIRCRAFT SET 1

Included / Incluye: AK2051 FS 16440 Light Gull Gray, AK2052 FS 17875 White, AK2053 FS 33613 Radome Tan, AK2054 FS 35164 Intermediate Blue, AK2055 FS 36307 Light Sea Grey, AK2056 FS 35237 Medium Grey, AK2057 FS 36375 Light Ghost Grey, AK2058 FS 36320 Dark Ghost Grey



AK2060
WW2 IJN AIRCRAFT COLORS

Included / Incluye: AK2061 J3 Hai-iro (Grey), AK2062 J3 SP (Amber Grey), AK2063 D1 Deep Green Black, AK2064 D2 Green Black, AK2065 C2 Trainer Yellow, AK2066 Q1 Anti-Glare Blue-Black, AK2067 M3 (M) Mitsubishi Interior Green, AK2068 M3 (N) Nakajima Interior Green



AK2140
U.S. MODERN AIRCRAFT SET 2

Included / Incluye: AK2057 FS 36375 Light Ghost Grey, AK2058 FS 36320 Dark Ghost Grey, AK2141 FS 36270 Medium Grey, AK2142 FS 36251 Aggressor Grey, AK2143 FS 36176 F-15 Dark Grey, AK2144 FS 36118 Medium Gunship Grey, AK2145 FS 35450 Air Superiority Blue, AK2146 FS 16473 ADC Grey



AK2150
ISRAELI AIR FORCE COLORS

Included / Incluye: AK2015 FS 34424 Green (RAF Sky), AK2057 FS 36375 Light Ghost Grey, AK2058 FS 36320 Dark Ghost Grey, AK2103 FS 30219 Dark Tan, AK2151 FS 33531 Sand, AK2152 FS 34227 Green, AK2153 FS 34258 Green, AK2154 FS 35622 Light Blue



AK2230
**WW2 US NAVY &
 USMC AIRCRAFT COLORS**

Included / Incluye: AK2231 M-485 Light Gray, AK2232 M-485 Blue-Gray, AK2233 Sea Blue, AK2234 Dark Sea Blue, AK2054 Intermediate Blue, AK2052 Insignia White



AK2240
SOVIET AIRCRAFT COLORS 1941-1949

Included / Include: AK2241 A-14 Interior Steel Grey, AK2242 AMT-4 (A-24m) Green, AK2243 AMT-6 (A-26m) Black, AK2244 AMT-7 (A-28m) Light Blue, AK2245 AMT-11 Blue-Grey, AK2246 AMT-12 Dark Grey, AK2247 AMT-1 Light Brown, AK2248 A-21m Light Yellowish Brown



AK2260
WW2 IJAAF
AIRCRAFT COLORS

Included / Include: AK2261 #1 Haiyokushoku (Grey-Green), AK2262 #3 Hairanshoku (Blue-Grey), AK2263 #7 Ohryoku Nana Go Shoku (Olive Brown), AK2264 #21 Midori Iro (Green), AK2265 #27 Ao Midori Iro (Blue Green), AK2266 #29 Ki Midori Iro (Yellow Green), AK2267 #30 Karekusa Iro (Dry Grass Color), AK2268 #31 Cha Kasshoku (Tea Color)



AK2270
WWI GERMAN AIRCRAFT COLORS

Included / Include: AK2271 WWI German Fokker Grey, AK2272 WWI German Light Green, AK2273 WWI German Dark Green, AK2274 WWI German Mauve, AK2275 WWI German Red Brown, AK2276 WWI German Light Blue, AK2277 WWI German Lilac, AK2278 WWI German Grey-Green Primer



AK2080
RAF DAY FIGHTER SCHEME

Included / Include: AK2011 RAF Dark Green, AK2013 RAF Medium Sea Grey, AK2014 RAF Ocean Grey, AK2015 RAF Sky



AK2090
LUFTWAFFE FIGHTER
COLORS 1941-44

Included / Include: AK2007 RLM 74, AK2008 RLM 75, AK2009 RLM 76, AK2091 RLM 04



AK2100
USAF TAC SOUTHEAST ASIA
(SEA) SCHEME

Included / Include: AK2101 FS 34079 Dark Green, AK2102 FS 34102 Medium Green, AK2103 FS 30219 Dark Tan, AK2104 FS 36622 Camouflage Grey



AK2130
USAF EUROPEAN CAMO

Included / Include: AK2101 FS 34079 Dark Green, AK2102 FS 34102 Medium Green, AK2105 FS 36081 Grey, AK2106 FS 34092 Dull Dark Green



AK2160
EARLY ISRAELI
AIR FORCE COLORS

Included / Include: AK2161 MNO 2036 Small Khaki Avion, AK2162 RAL 5008 Grey-Blue (Graublau), AK2163 RAL 7044 Silk Grey (Seidengrau), AK2164 RAL 8008 Olive Brown (Olivbraun)



A2170
LUFTWAFFE COLORS 1960S-1970S

Included / Include: AK2171 RAL 2005 Luminous Orange (Leuchtorange), AK2172 RAL 6014 Yellow Olive (Gelboliv), AK2173 RAL 7001 Silver Grey (Silbergrau), AK2174 RAL 7012 Basalt Grey (Basaltgrau), AK478 Xtreme Metal White Aluminium



AK2180
LUFTWAFFE COLORS 1990S-2000S

Included / Include: AK2056 FS 35237 Medium Grey, AK2057 FS 36375 Light Ghost Grey, AK2058 FS 36320 Dark Ghost Grey, AK2174 RAL 7012 Basalt Grey (Basaltgrau), AK2175 RAL 7030 Stone Grey (Steingrau)



AK2200
WW2 USAAF AIRCRAFT
COLORS VOL. 1

Included / Include: AK2201 Dark Olive Drab 41, AK2202 Medium Green 42, AK2203 Neutral Grey 43



AK2220
WW2 US AIRCRAFT
INTERIOR COLORS

Included / Include: AK2106 Dull Dark Green, AK2205 Bronze Green, AK2206 Yellow Green, AK2207 Yellow Zinc Chromate, AK2303 Interior Green



AK2210
WW2 USAAF AIRCRAFT
COLORS VOL. 2

Included / Include: AK2201 Dark Olive Drab 41, AK2204 ANA613 Olive Drab, AK479 Xtreme Metal Aluminium, AK480 Xtreme Metal Dark Aluminium, AK488 Xtreme Metal Matte Aluminium



AK2250
SOVIET AIRCRAFT COLORS
1937-1941

Included / Include: AK2251 AE-9/All Light Grey, AK2252 All Green, AK2253 All Light Blue, AK2254 A-18f Light Grey-Blue, AK2255 A-19f Grass Green



AK2280
WWI RFC & RNAS
AIRCRAFT COLORS

Included / Include: AK2281 PC10 Early, AK2282 PC10 Late, AK2283 PC12, AK2284 Battleship Grey



AK2290
CLEAR DOPED LINEN

Included / Include: AK2291 Clear Doped Linen, AK2292 Clear Doped Linen ver.2, AK2293 Bleached Linen



AK2300

SOVIET AIRCRAFT COLORS 1950-1970

Included / Include: AK2301 Cockpit Turquoise, AK2302 Radome Green, AK2303 Interior Green, AK2304 Cockpit Grey, AK479 Xtreme Metal Aluminium, AK480 Xtreme Metal Dark Aluminium



AK2320
LUFTWAFFE PRE-WAR
CAMOUFLAGE COLORS

Included / Include: AK2026 RLM 61, AK2027 RLM 62, AK2034 RLM 63, AK2003 RLM 65





AIR SERIES

THE BEST PRODUCTS FOR YOUR MODELS



2.5 FIGURE SERIES / SERIE DE FIGURAS

The paints from Figure Series are specially developed for painting figures, with a new formula with the finest pigments. They are designed to be primarily applied with a brush, and produce a matte finish suitable for this genre. For airbrushing, you can dilute them by adding 40% of AK712 Acrylic Thinner. This wide range of colors has been carefully selected by the most renowned figure painters.

Las pinturas de la Serie Figure están especialmente desarrolladas para pintar figuras, con una nueva fórmula y con los mejores pigmentos. Están diseñados para aplicarse principalmente con un pincel y producen un acabado mate muy adecuado para este género. Para aerografía, puede diluirlos agregando el 40% del diluyente acrílico AK712. La amplia gama de colores ha sido cuidadosamente seleccionada por los pintores de figuras más reconocidos.

FIGURE SERIES



AK11620
LEATHER AND BUCKLES

Included / Incluye: AK11110 Leather Brown, AK11078 Medium Orange, AK11058 Decomposed Flesh, AK11026 Tenebrous Grey, AK11193 Rusty Gold, AK11210 Natural Steel

This 3Gen set of six colors have been designed to paint very common accessories on miniature figures from any period: leather, buckles, buttons, boots, etc. Este set de pinturas 3Gen de seis colores es diseñado para pintar accesorios muy habituales de las figuras en miniatura de cualquier época: pieles, hebillas, botones, botas, etc.



AK11621
FLESH AND SKIN COLORS

Included / Incluye: AK11405 Dark Shadow Flesh, AK11404 Shadow Flesh, AK11401 Base Flesh, AK11402 Light Flesh, AK11403 Highlight Flesh, AK11406 Reddish Black

This 3Gen set of six colors have been designed to paint skin and flesh tones in miniature (previously AK3010). Este set de pinturas 3Gen de seis colores ha sido diseñado para pintar tonos de carne y piel en miniatura (AK3010 anteriormente).



AK11622
PANZER CREW BLACK UNIFORMS

Included / Incluye: AK11029 Black Uniform Shadow, AK11407 Black Uniform Base, AK11021 Basalt Grey, AK11013 Pale Grey, AK11062 Old Rose, AK11006 Silver Grey

The tones of this 3Gen set have been selected to recreate the mythical black German Panzer Crew uniforms used by Wehrmacht (Heer) and Waffen SS. Los colores de este set de pinturas 3Gen se han seleccionado para recrear los míticos uniformes negros de la tripulación panzer alemana utilizados por la Wehrmach (Heer) y las Waffen SS.



AK11623
WAFFEN SS 44 DOT UNIFORM COLORS 3G

Included / Incluye: AK11112 Grim Brown, AK11408 Chocolate Brown, AK11119 Cork, AK11411 Light Green, AK11409 Orange Tan, AK11410 Dark Green

The tones of this 3Gen set have been selected for painting the legendary M-44 uniforms used by German SS troops during WWII. Los colores de este set 3Gen han sido seleccionados para pintar los legendarios uniformes M-44 utilizados por las tropas de las SS alemanas durante la Segunda Guerra Mundial.



AK11624
SPLITTERMUSTER UNIFORM

Included / Incluye: AK11414 Splittermuster Base, AK11016 Grey-Green, AK11033 Dark Sand, AK11415 Splittermuster Green Spots, AK11419 Waffen Red Brown, AK11158 Reflective Green

The tones of this 3Gen set have been selected for painting figures dressed with the Splittermuster type camouflage uniform. Los colores de este set 3Gen han sido seleccionados para pintar figuras con el uniforme de camuflaje tipo Splittermuster.



AK11625
WAFFEN SS AUTUMN/WINTER CAMOUFLAGE

Included / Incluye: AK11418 Brown Black, AK11416 Waffen Brown Grey, AK11017 Reddish Grey, AK11112 Grim Brow, AK11417 Waffen Brown, AK11100 Light Brown

The tones of this 3Gen set have been selected for painting the autumn/winter variants of oak leaf, palm tree & plane tree-patterned uniforms used by Waffen-SS troops during WWII. Los colores de este set de 3Gen se han seleccionado para pintar los legendarios uniformes de otoño/invierno utilizados por las tropas de las Waffen-SS durante la Segunda Guerra Mundial.



AK11626
WAFFEN SS SPRING-SUMMER CAMOUFLAGE

Included / Incluye: AK11113 Chocolate, AK11120 Mud Brown, AK11115 Light Earth, AK11139 Golden Olive, AK11420 Waffen Green, AK11160 Black Green

The tones of this 3Gen set have been selected for painting the legendary spring/summer uniforms used by Waffen-SS troops during WWII. Los colores de este set 3Gen se han seleccionado para pintar los legendarios uniformes de primavera/verano utilizados por las tropas de las Waffen-SS durante la Segunda Guerra Mundial.



AK11627
GERMAN FIELD GREY UNIFORMS

Included / Incluye: AK11153 Extra Dark Green, AK11425 Green Uniform, AK11424 Grey Green, AK11025 German Grey, AK11423 Grey Uniform, AK11426 Grey Blue

The tones of this 3Gen set have been selected for painting figures of WW2 German soldiers with field grey uniforms. Los colores de este set 3Gen han sido seleccionados para pintar figuras con los uniformes Field Grey de los soldados alemanes de la Segunda Guerra Mundial.

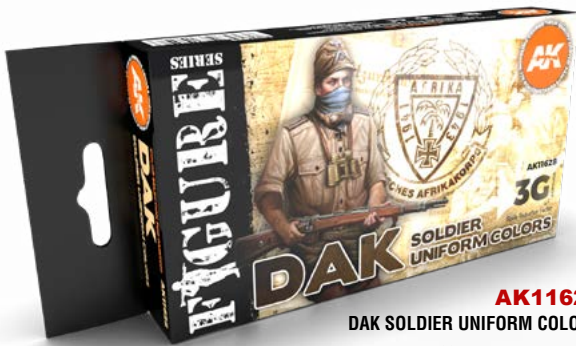

AK11628

DAK SOLDIER UNIFORM COLORS

Included / Incluye: AK11109 Dark Brown, AK11440 Dak Desert Uniform Base, AK11116 Tan Yellow, AK11153 Extra Dark Green, AK11427 Green Uniform Base, AK11428 Light Green Uniform

The tones of this 3Gen set have been selected for painting figures with tropical uniforms used by the German Army in Africa and Sicily during WW2, called Deutsche Afrika Korps (DAK).

Los colores de este set 3Gen han sido seleccionados para pintar figuras con uniformes tropicales utilizados por el ejército alemán en África y Sicilia durante la Segunda Guerra Mundial. Llamado Deutsche Afrika Korps (DAK).



AK11629

WWI GERMAN UNIFORM 3G

Included / Incluye: AK11153 Extra Dark Green, AK11133 Dark Green Grey, AK11135 Faded Green, AK11104 Saddle Brown, AK11040 Sahara Yellow, AK11026 Tenebrous Grey

The tones of this 3Gen set have been selected for painting figures with WWI German uniforms.

Los colores de este set 3Gen han sido seleccionados para pintar figuras con uniformes alemanes de la Primera Guerra Mundial.



AK11630

MODERN DESERT UNIFORM COLORS

Included / Incluye: AK11003 White Grey, AK11057 Vampire Flesh, AK11418 Brown Balck, AK11120 Mud Brown, AK11435 Field Drab, AK11424 Grey Green

This 3Gen set includes a selection of tones for painting modern uniforms used by soldiers of armies like US, British, Russian or other countries around the world.

Este set 3Gen contiene una selección de colores para pintar uniformes modernos utilizados por soldados de ejércitos como Estados Unidos, Gran Bretaña, Rusia y otros países del mundo.



AK11631

IDF UNIFORM COLORS

Included / Incluye: AK11412 Medium Green, AK11148 Olive Green, AK11344 Field Drab, AK11436 Canvas Tone, AK11422 Oche Khaki, AK11418 Brown Black

This 3Gen set includes a selection of tones for painting any Israeli Defence Forces soldier, from past wars, to the present day.

Este set 3Gen contiene una selección de colores para pintar cualquier uniforme de los soldados del Ejército de Defensa de Israel durante los años de conflicto y en la actualidad.

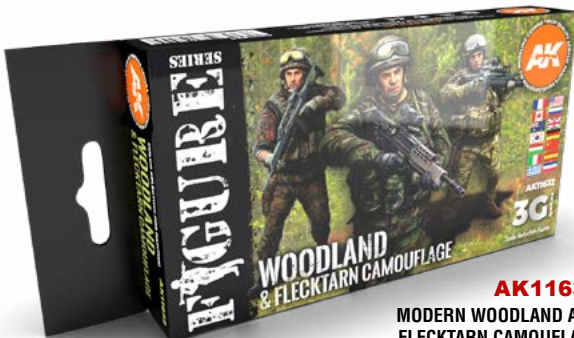

AK11632

MODERN WOODLAND AND FLECKTARN CAMOUFLAGE

Included / Incluye: AK11411 Light Green, AK11412 Medium Green, AK11418 Brown Black, AK11418 Brown Black, AK11149 Intermediate Green, AK11114 Deck Tan, AK11434 Red Brown

This 3Gen set includes a selection of tones for painting modern woodland uniforms from countries around the world.

Este set 3Gen contiene una selección de tonos para pintar uniformes modernos Woodland de países de todo el mundo.



AK11633

FRENCH UNIFORM COLORS

Included / Incluye: AK11427 Green Uniform Base, AK11436 Uniform Light, AK11435 Field Drab, AK11422 Ocher Khaki, AK11111 Dark Brown, AK11120 Mud Brown

This 3Gen set includes a selection of tones for painting the uniforms of the French Army in various theatres during WWI and WW2.

Este set 3Gen contiene una selección de tonos para la pintura de figuras con uniformes del ejército francés en diferentes teatros durante la Primera y Segunda Guerra Mundial.



AK11634

WWII US ARMY UNIFORM COLORS

Included / Incluye: AK11421 Dark Olive Green, AK11422 Ocher Khaki, AK11434 Red Brown, AK11433 US Olive Base Uniform, AK11435 US Field Drab, AK11436 Canvas Tone

This 3Gen set includes a selection of tones for painting figures with the most commonly seen uniforms worn by American soldiers during WWII.

Este set de 3Gen contiene una selección de tonos para la pintura de figuras con los uniformes más habituales de los soldados estadounidenses durante la Segunda Guerra Mundial.



AK11635

SOVIET WWII UNIFORM COLORS

Included / Incluye: AK11159 Russian Green, AK11430 Russian Uniform Base, AK11429 Russian Uniform Lights, AK11432 Russian Blue Base, AK11431 Russian Blue Lights, AK11093 Matt Red

This 3Gen set includes a selection of tones for painting figures with Soviet Army uniforms of WWII.

Este set 3Gen contiene una selección de tonos para la pintura de figuras con uniformes del Ejército soviético durante la Segunda Guerra Mundial.



AK11636

WWII BRITISH UNIFORM COLORS

Included / Incluye: AK11413 Denison Tan Base, AK11126 Green Brown, AK11150 Gunship Green, AK11434 Red Brown, AK11437 British Uniform Base, AK11058 Decomposed Flesh

This 3Gen set include the selection of tones for painting figures with uniforms used during the Second World War by the British Army.

Este set de pinturas 3Gen contiene una selección de tonos para la pintura de figuras con los uniformes utilizados durante la Segunda Guerra Mundial por el Ejército Británico.



AK11637

WWI FRENCH UNIFORMS

Included / Incluye: AK11439 French Greyish Blue Base, AK11132 Spectrum Blue, AK11190 Dark Sea Blue, AK11110 Leather Brown

This set of four 3Gen colors have been designed for painting figures with WWI French Uniforms.

Este set de cuatro colores 3Gen ha sido diseñado para pintar figuras con uniformes franceses de la Primera Guerra Mundial.



AK11638

WWI BRITISH UNIFORMS

Included / Incluye: AK11437 (WWI) British Uniform Base, AK11438 (WWI) British Uniform Light, AK11111 Burnt Umber AK111110 Leather Brown

This set of four 3Gen colors have been designed for painting WWI figures with British uniforms. They can also be used to represent some uniforms of the British Army in WWII, as these color tones were also used in that conflict.

Este set de cuatro colores 3Gen ha sido diseñado para pintar figuras de la Primera Guerra Mundial con uniformes británicos. También se pueden usar para representar algunos uniformes del ejército británico en la Segunda Guerra Mundial, ya que estos tonos de color también se usaron en ese conflicto.



AK11681

WWI ITALIAN CAMOUFLAGE

Included / Incluye: AK11150 Gunship Green, AK1135 Faded Green, AK11124 Middle Stone, AK11115 Light Earth, AK11108 Hull Red, AK11102 Deep Brown

The tones of this 3Gen set have been selected to recreate the Italian camouflage pattern uniforms used by Waffen SS during WWII.

Los colores de este set de pinturas 3Gen se han seleccionado para recrear los uniformes con patrón de camuflaje italiano utilizados por las Waffen SS durante la Segunda Guerra Mundial.



AK11682

VIETNAM GREEN AND CAMOUFLAGE COLORS

Included / Incluye: AK11410 Dark Green, AK11150 Gunship Green, AK1428 Light Green Uniform, AK11120 Mud Brown, AK11435 Field Drab, AK11424 Grey Green

This set contains six 3Gen colors selected for painting figures with uniforms used during the Vietnam War by the U.S. Army.

Este set contiene seis colores 3Gen seleccionados para la pintura de figuras con los uniformes utilizados durante la Guerra de Vietnam por el Ejército de Estados Unidos.





2.6 NAVAL SERIES / SERIE NAVAL

Our Naval Series currently includes a range of colors that are indispensable for painting models of warships which served with the US Navy, Royal Navy and German Kriegsmarine during World War Two.

Nuestra Serie Naval actualmente incluye una gama de colores que son indispensables para pintar modelos de buques de guerra que sirvieron con la Armada de los EE.UU., La Armada Real y la Kriegsmarine alemana durante la Segunda Guerra Mundial.

NAVAL



AK5000

WWII US NAVY CAMOUFLAGES

Included / Incluye: AK5001 Deck Blue 20B, AK5002 Haze Gray 5H, AK5003 Ocean Gray 5O, AK5004 Navy Blue 5N, AK5005 Sea Blue 5S, AK5006 Light Gray 5L

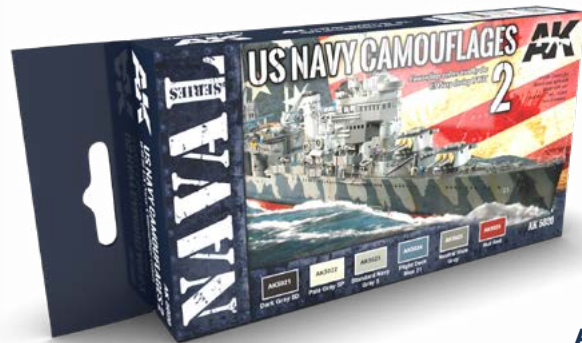

AK5020

WWII US NAVY CAMOUFLAGES SET 2

Included / Incluye: AK5021 Dark Gray 5D, AK5022 Pale Gray 5P, AK5023 Standard Navy Gray 5, AK5024 Flight Deck Blue 21, AK5025 Neutral Haze Gray, AK5026 Hull Red



AK5030

WWII ROYAL NAVY CAMOUFLAGES SET 1

Included / Incluye: AK5031 RN Hull Red, AK5032 Wooden Deck, AK5033 507A Admiralty Dark Grey, AK5034 507B Admiralty Medium Grey, AK5035 507C Admiralty Light Grey, AK5036 B5 Dark Blue Grey

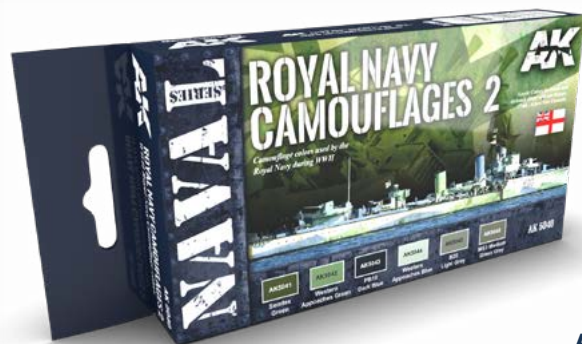

AK5040

WWII ROYAL NAVY CAMOUFLAGES SET 2

Included / Incluye: AK5041 Semtex Green, AK5042 Western Approaches Green, AK5043 PB10 Dark Blue, AK5044 Western Approaches Blue, AK5045 B20 Light Grey, AK5046 MS3 Medium Green Grey



AK559

WWII GERMAN WARSHIP CAMOUFLAGES

Included / Incluye: AK730 Wooden Deck, AK731 RAL 8013 Schiffsbodenfarbe III Rot 5, AK732 RAL 7038 Hellgrau, AK733 RAL 7000 Dunkelgrau 51, AK734 RAL 7037 Dunkelgrau, AK735 Flat Black



2.7 CIVIL SERIES / SERIE CIVILES

The Civil Series comprises three AKrylic sets intended for painting upholstery and other interior elements of your model cars, vans and trucks, in the most commonly seen colors.

La Serie Civil comprende tres sets destinados a pintar tapizados y otros elementos interiores de sus modelos de coches, camionetas, motos y camiones en los tonos más comunes.



AK11683

BLACK INTERIOR AND CREAM WHITE

Included / Incluye: AK11057 Vampiric Flesh, AK11008 Grimy Grey, AK11004 Ivory, AK11026 Tenebrous Grey, AK11022 Dark Grey, AK11020 English Grey



AK11684

YELLOW, BROWN & GREY INTERIORS

Included / Incluye: AK11015 Dark Sea Grey, AK110121 Sky Grey, AK11045 Seep Yellow, AK11102 Deep Brown, AK11101 Orange Brown



AK11685

RED AND BLUE INTERIOR COLORS

Included / Incluye: AK11098 Black Red, AK11092 Matt Red, AK11074 Deep Orange, AK11189 Dark Prussian Blue, AK11177 Ducat Blue, AK11175 Sky Blue



3rd GENERATION ACRYLICS

Ref.	Type	Name	Color	Tamiya	Humbrol	Vallejo	Gunze / Mr. Hobby	Testors	RLM	RAL	FS	Revell	Real Colors	Citadel
AK11001		White		XF-2	34	951	11	1768	21	9016	37925	5	RC004	
AK11002		Offwhite				820	316			9001	27780		RC222	
AK11003		White Grey				993	311							
AK11004		Ivory			41	918	21	2709			37855	10		
AK11005		Greenish White			90		31				17773			
AK11006		Silver Grey			28	883	51	1733		9002	36622			51058
AK11007		Rock Grey			129		57	1730			26440	301		
AK11008		Grimy Grey					313				33531			
AK11009		Warm Grey		XF-20			321							
AK11010		Medium Grey		XF-25		907	62		76		36473			
AK11011		Blue-Grey		XF-12	89	973	67	1562			25526			
AK11012		Sky Grey		XF-19	196	989	334			7004	36463	371		
AK11013		Pale Grey		XF-80		990	53	1728		7001	36300			
AK11014		Medium Sea Grey					61				36307			
AK11015		Dark Sea Grey		XF-53	140	991	82	1729			36231	70		
AK11016		Grey-Green		XF-73		886	70		2				RC265	
AK11017		Reddish Grey												
AK11018		Neutral Grey		XF-66	27	992	68	2160			36173			
AK11019		Graphite		XF-22			22							
AK11020		English Grey		XF-54		836	305				36118			
AK11021		Basalt Grey		XF-77	106	869	83		75	7012	36152	47		
AK11022		Dark Grey		XF-24	85	994	27	1579			26008	302		
AK11023		Lead Grey					333			7022	34031			
AK11024		Ash Grey			123	866	68		66		26008			
AK11025		German Grey		XF-63	67	995	404	1592		7016	26044	78		
AK11026		Tenebrous Grey					452							
AK11027		Rubber Black		XF-85			77							
AK11028		Smoke Black		XF-69		862	401	4795		7021	37031	109		
AK11029		Black		XF-1	33	950	12	1583	22	9004	37038		RC001	
AK11030		Beige				917					23594			
AK11031		Buff		XF-57	103	976				1001	23578			51032
AK11032		Pale Sand				837					23722		RC018	
AK11033		Dark Sand		XF-88	74	847	36							
AK11034		Medium Sand				977	71				30257		RC030	
AK11035		Sand Yellow				916				1002	20260			
AK11036		Ice Yellow			76	858								
AK11037		Pastel Yellow									33798			
AK11038		Pale Yellow				949					33727			
AK11039		Purulent Yellow				806			5					
AK11040		Sahara Yellow												
AK11041		Golden Yellow				948				1017				
AK11042		Volcanic Yellow					24				13538			
AK11043		Dirty Yellow					329							
AK11044		Yellow		X-8	69	953	413	1514	4	1003	23655	12		
AK11045		Deep Yellow				915	4			1023				
AK11046		Radiant Yellow												
AK11047		Lemon Yellow		XF-3	99	952		2717		1018				
AK11048		Laser Yellow				954								
AK11049		Fluorescent Yellow				730	97			1026	38907			
AK11050		Light Flesh				928					31670			
AK11051		Luminous Flesh					318				21667			
AK11052		Basic Skin Tone				815					21670			
AK11053		Radiant Flesh				955					22516			
AK11054		Medium Flesh Tone				860								
AK11055		Sunny Skin Tone		XF-15		845								
AK11056		Dark Flesh			61	927	44	1516				35		
AK11057		Vampiric Flesh					336				13522			
AK11058		Decomposed Flesh		XF-78			85				33510			
AK11059		Pastel Pink									31669			
AK11060		Sickly Pink									31638			

2.8 COLOR CONVERSION CHART / TABLA DE CONVERSIÓN DE COLORES

Ref.	Type	Name	Color	Tamiya	Humbrol	Vallejo	Gunze / Mr. Hobby	Testor	RLM	RAL	FS	Revell	Real Colors	Citadel
AK11061		Salmon				835								
AK11062		Old Rose		X-17	200	944	19							
AK11063		Brown Rose				803								
AK11064		Beige Red				804				3012	31433			51037
AK11065		Intense Pink				958								51070
AK11066		Laser Magenta												
AK11067		Magenta				945				4006				50033
AK11068		Fluorescent Magenta				735	99							
AK11069		Pastel Violet												
AK11070		Blue Violet				811								
AK11071		Lilac					49							
AK11072		Deep Violet												
AK11073		Purple		X-16	68	959	39				37100	53		
AK11074		Deep Purple												
AK11075		Violet Red				812								
AK11076		Pastel Peach												
AK11077		Light Orange				911				2008	32473			
AK11078		Medium Orange												
AK11079		Burn Orange		X-6		805				2012				
AK11080		Deep Orange			18	851	14			2004			RC009	
AK11081		Fluorescent Orange				733	98	2041		2005	38903		RC207	
AK11082		Luminous Orange												
AK11083		Dead Red					29							
AK11084		Ruby				802								
AK11085		Cadmium Red			131	910					21400			
AK11086		Amaranth Red				829				2001				
AK11087		Scarlet Red				817				2002	21310			
AK11088		Deep Red		X-F7	153		23							
AK11089		Blood Red			174	909				3020	31302	330		
AK11090		Vermillion			60	947	86			3031	31350		RC006	
AK11091		Carmine		X-7	19	908	3	1503		3002	21105	31		
AK11092		Matt Red				957	13	4714		3013	31136			
AK11093		Brick Red				946	327				11136			
AK11094		Bordeaux Red					43							
AK11095		Dirty Red			20	926	33	1501		3026		32		
AK11096		Wine Red					466							
AK11097		Burnt Red		XF-9		814	47			8012				
AK11098		Black Red				859		2152					RC068	
AK11099		Ocher Orange				P								
AK11100		Light Brown				929								
AK11101		Orange Brown			9	981				8023	30252	80	RC031	51040
AK11102		Deep Brown				818	453				20100			
AK11103		Medium Rust				P	7						RC081	
AK11104		Saddle Brown		XF-79		940					30111			
AK11105		Light Rust												
AK11106		Mahogany Brown			113	846	344	1785		8002		83		
AK11107		Dark Rust		XF-68			17							
AK11108		Hull Red				985	84			8017	30059			
AK11109		Dark Brown		XF-64		826					30140			
AK11110		Leather Brown				871	456			8027	30051			
AK11111		Burnt Umber		XF-51		941					30097		RC323	
AK11112		Grim Brown				822	462			8019	37056			
AK11113		Chocolate (Chipping)		XF-10	98	872		1540		8017	20062			
AK11114		Deck Tan		XF-55	128	986	53	1741		7038	26496	374	RC019	
AK11115		Light Earth				819	79				22446			
AK11116		Tan Yellow				912	44			1011	33245			
AK11117		Golden Brown				877					33275			51004
AK11118		Ochre			63	913	34	1706			33434	89		
AK11119		Cork		XF-52	62	843	66	1737	79			85		
AK11120		Mud Brown				825	341				30140			

Ref.	Type	Name	Color	Tamiya	Humbrol	Vallejo	Gunze / Mr. Hobby	Testor	RLM	RAL	FS	Revell	Real Colors	Citadel
AK11121		Tan Earth		XF64	119	874	37				30219			
AK11122		Green Ochre		XF59	94	914	402					88		
AK11123		Japanese Brown			83	923					30266			
AK11124		Middle Stone		XF60		882	401			1027				
AK11125		Grey-Brown		XF72										
AK11126		Green-Brown		XF49	26	879	81			8000		86		
AK11127		British Khaki			29	921	72					87		
AK11128		Luminous Green												
AK11129		Fluorescent Green					100				38901			
AK11130		Pistachio												
AK11131		Pastel Green												
AK11132		Green-Grey		XF21	65	971	74				34414	55		
AK11133		Dark Green-Grey			149		302	1764			34092		RC230	
AK11134		Green Sky			120	974	50	1716			24272			
AK11135		Faded Green		XF76			48							
AK11136		Frog Green												
AK11137		Lime Green		X15	38	827	16					60		
AK11138		Interior Yellow Green		XF4			58				33481			
AK11139		Golden Olive				857								
AK11140		Grass Green												
AK11141		Light Green		X28	80	942					24190			51024
AK11142		Deep Green				969	26				14115			
AK11143		Mint Green												
AK11144		Emerald				838	46							
AK11145		Lizard Green												
AK11146		Dark Green			2	970		1524		6029	24108	61		
AK11147		Olive Green		XF5		967								
AK11148		Medium Olive Green				850	464				34128			
AK11149		Intermediate Green			82	891	312			6011	34138			
AK11150		Gunship Green		XF26	30	895	6				34092			
AK11151		Brownish Green												
AK11152		Alga Green				833	422			6025				
AK11153		Extra Dark Green		XF27	91	896			73	6012				
AK11154		German Field Grey		XF65	92	830	73			7009	34086	79		
AK11155		Command Green		XF67		888	80		71	6006	24079			
AK11156		Camouflage Green		XF81		887	52		81		34087			
AK11157		US Dark Green		XF13	116	893	64	1710			34079	67		
AK11158		Reflective Green		XF58	102	890	320	1716		6003	34082	45		
AK11159		Russian Green		XF62		894	420		80		34083			
AK11160		Black Green		XF11		980	59						RC034	50013
AK11161		Pale Blue		XF23		906	418		65		35352			
AK11162		Spectrum Blue					67							
AK11163		Intermediate Blue		XF25	144	903		1720			36164	79		
AK11164		Dark Blue-Grey			157	904					35189			
AK11165		Grey-Blue			109	943	42				35177		RC256	
AK11166		French Blue				900	305				35240			
AK11167		Anthracite Grey		XF18			42						RC297	
AK11168		Pastel Blue					41							
AK11169		Blue-Green				808				5018	35275			51020
AK11170		Aquatic Turquoise				840								
AK11171		Turquoise				966								
AK11172		Archaic Turquoise												
AK11173		Ocean Blue		XF50										
AK11174		Snow Blue												
AK11175		Sky Blue			47	961		1508				50		
AK11176		Deep Sky Blue				844	323				35250			
AK11177		Ducat Blue				841	25			5012				
AK11178		Fluorescent Blue				736								
AK11179		Ultramarine				839								
AK11180		Imperial Blue					465							
AK11181		Dark Blue			25	925	5				35095	56		51015
AK11182		Deep Blue			14	930	15	2715				52	RC010	
AK11183		Amethyst Blue					35							
AK11184		Medium Blue		X13	52	963	88	2702	24	5019	25102	98		
AK11185		Star Blue					322							

Ref.	Type	Name	Color	Tamiya	Humbrol	Vallejo	Gunze / Mr. Hobby	Testor	RLM	RAL	FS	Revell	Real Colors	Citadel
AK11186		Light Prussian Blue		XF8	25	965				5000	35052	156		
AK11187		Strong Dark Blue					326				35044			
AK11188		Oxford			104	807						350	RC257	
AK11189		Dark Prussian Blue		X3	15	899	5	1511			35048	54		
AK11190		Dark Sea Blue		XF17	79	898	54			5004	35042	77		
AK11191		Gold					9				17043			
AK11192		Old Gold												
AK11193		Rusty Gold												
AK11194		Brass			54	801		1582				92		51066
AK11195		Rusty Brass												
AK11196		Bronze			55	998						95		51063
AK11197		Copper		XF6	12	999	10	1551				93		51065
AK11198		Burnt Tin		XF28	171									
AK11199		Metallic Blue					88							
AK11200		Astral Beryllium					63							
AK11201		Cobalt Blue												
AK11202		Anodized Violet												
AK11203		Foundry Red												
AK11204		Emerald Metallic Green												
AK11205		Metallic Green					89							
AK11206		Pearl												
AK11207		Aluminium		XF16		993					36628		RC020	
AK11208		Dark Aluminium												
AK11209		Silver		X11	11	997	8	1790			17178	90		
AK11210		Natural Steel		XF56	56	864	18	1781				99		
AK11211		Oily Steel			27002	865	38	1401						
AK11212		Gun Metal		X10	53	863	76	1795						
AK11213		Clear Red				934	90							
AK11214		Clear Blue				938	93							
AK11215		Clear Smoke				939	95							
AK11216		Clear Green				936	94							
AK11217		Clear Yellow				937	91						RC507	
AK11218		Clear Orange				935	92							
AK11219		Sepia INK												
AK11220		Turquoise INK												
AK11221		Skin INK												
AK11222		Sooty Black INK												
AK11223		Carbon Black INK												
AK11224		Purple INK												
AK11225		Luminous Green INK												
AK11226		Dark Green INK												
AK11227		Penetrating Red INK												
AK11228		Night Blue INK												
AK11229		Burnt Umber INK												
AK11230		Titanium White INK												
AK11231		Retarder												
AK11232		Metal Medium												
AK11233		Glaze Medium												
AK11234		Matte Medium												
AK11235		Gloss Medium												
AK11236		Crackle Medium												





Ref.	Type	Name	Color	Tamiya	Humbrol	Vallejo	Gunze / Mr. Hobby	Testor	Lifecolor	RAL	FS	Hataka	Real Colors	AK OLD REFERENCE
AK11301	AFV	WWI British Khaki Brown Base												AK4042
AK11302	AFV	WWI French Milky Coffee				71027			UA097		23448			AK4051
AK11303	AFV	WWI French Artillery Grey				71257					36176			AK4052
AK11304	AFV	WWI French Brown									31090			AK4053
AK11305	AFV	WWI French Green 1				71006					34097			AK4054
AK11306	AFV	WWI French Green 2												AK4055
AK11307	AFV	RAL 7009 Hellgrau								7009		233	54	
AK11308	AFV	RAL 6007 Grün				71019				6007		298	49	
AK11309	AFV	RAL 6003 Olivgrün opt.1				71092	H405		UA206	6003		169	47	
AK11310	AFV	RAL 6003 Olivgrün opt.2												AK755
AK11311	AFV	RAL 6011 Resedagrün								6011				AK715
AK11312	AFV	RAL 6011B Resedagrün												AK716
AK11313	AFV	RAL 7008 Graugrün				71116			UA212	7008		304	53	
AK11314	AFV	RAL 7008 Graugrün Opt 2												
AK11315	AFV	RAL 7017 Dunkelbraun				71248			UA210	7017			56	
AK11316	AFV	RAL 7021 Dunkelgrau				71056			UA207	7021	34086	164	57	
AK11317	AFV	RAL 7027 Grau				71118			UA202	7027		306	58	
AK11318	AFV	RAL 7028 Dunkelgelb (Initial)				71025	H403		UA204	7028	33434	244	60	
AK11319	AFV	RAL 7028 Dunkelgelb Ausgabe 1944								7028		250	61	
AK11320	AFV	RAL 7028 Dunkelgelb (Variant)								7028				
AK11323	AFV	RAL 6040 F9 Hellooliv				71247				6040 F9		281	90	
AK11325	AFV	RAL 1039 F9 Sandbeige				71244				1039 F9		278	88	AK728
AK11326	AFV	RAL 8031 F9 Sandbraun				71246				8031 F9		280	92	AK727
AK11327	AFV	RAL 8000 Gelbbraun				71272			UA203	8000		303	63	AK702
AK11328	AFV	RAL 8012 Rotbraun				71271			UA211	8012		175	67	AK717
AK11329	AFV	RAL 8013 Rotbraun								8013			66	AK731
AK11330	AFV	RAL 8017 Rotbraun				71041	H406		UA205	8017		147	68	AK718
AK11331	AFV	RAL 8020 Braun				71117			UA201	8020		35	69	AK700
AK11333	AFV	Cremeweiss				71075				1001	23717	184	46	AK092
AK11334	AFV	Olive Drab Base									24098			AK134
AK11335	AFV	N°1 Light Green (FS34151)				71137					34151	211	28	AK4214
AK11336	AFV	N°5 Earth Brown (FS30099)				71290			UA087		30099	256		AK4221
AK11337	AFV	N°6 Earth Yellow (FS30257)				71291					30257	212	30	AK4222
AK11338	AFV	N°8 Earth Red (FS30117)				71293					30117			AK4223
AK11339	AFV	N°9 Olive Drab (FS33070)									33070			AK4211
AK11340	AFV	N°13 Desert Sand (FS30279)				71140	H346		UA089		30279	68		AK4224
AK11341	AFV	Ocean Gray (FS35164)									35164			AK4225
AK11342	AFV	Dark Green (FS34102)				71289			UA002		34102	21	83	AK4231
AK11343	AFV	MERDC Sand (FS30277)				71138			UA019		30277	187	84	AK4233
AK11344	AFV	Field Drab (FS30118)				71139			UA016		30118	209	85	AK4234
AK11345	AFV	APC Interior Light Green (FS24533)									24533		78	AK4012
AK11346	AFV	Forest Green (FS34079)				71294			UA001		34079	16	27	
AK11347	AFV	Australian Camouflage Brown									30219			AK4022
AK11348	AFV	Australian Camouflage Green									34088			AK4021
AK11349	AFV	CARC Tan 686A (FS33446)				71122	53				33446		79	AK122
AK11350	AFV	Modern Spanish Green												
AK11351	AFV	Wood Base									23564			AK779
AK11352	AFV	IDF Modern Grey					C530						94	
AK11353	AFV	IDF Sand Grey 1970s-1980s				71142	C529	2138					95	
AK11354	AFV	IDF Early Sand Yellow				71141	C528						96	
AK11355	AFV	IDF Green												
AK11356	AFV	SLA Blue									34158			AK794
AK11357	AFV	LAF Green												AK795
AK11358	AFV	NATO Green				71250			UA303	6031 F9		152	80	AK796
AK11359	AFV	NATO Brown				71249			UA302	8027 F9		188	81	AK797
AK11360	AFV	NATO Black				71251			UA301	9021 F9		125	82	AK799
AK11361	AFV	New Iraqi Army Sand									23531			AK725
AK11362	AFV	British Sand Yellow									33695			AK726
AK11363	AFV	French Army Desert Sand				71064					17178			AK4081
AK11364	AFV	French Army Green												AK4082
AK11365	AFV	French Army Grey-Blue					H417							AK4083
AK11366	AFV	Mustard Yellow				71033					33637			AK4132
AK11367	AFV	Base Green (Protective)												
AK11368	AFV	Russian Green 4B0				71017	136	2129					73	
AK11369	AFV	Russian Dark Brown 6K				71282		2126				317	74	
AK11370	AFV	Russian Sand 7K				71283			UA242			318	75	
AK11371	AFV	Protective Green 1920s-1930s											76	

Ref.	Type	Name	Color	Tamiya	Humbrol	Vallejo	Gunze / Mr. Hobby	Testor	Lifecolor	RAL	FS	Hataka	Real Colors	AK OLD REFERENCE
AK11372	AFV	Washable White Paint												AK751
AK11373	AFV	Khaki green No.3				71330						64	33	AK4035
AK11374	AFV	Silver Grey No.28				71401			UA264				38	AK4032
AK11375	AFV	State No.34				71012	H73		UA265				39	AK4033
AK11377	AFV	Light Stone No.61				71143			UA266				40	AK4034
AK11378	AFV	Portland Stone No.64				71288			UA267				41	AK4031
AK11381	AFV	British Dark Olive Green PFI							UA269				42	
AK11382	AFV	British Desert Pink ZI				71400			UA268				43	
AK11383	AFV	British Light Mud				71284			UA272				44	
AK11384	AFV	S.C.C. No.1A Very Dark Brown				71039			UA274		30059	77	34	
AK11385	AFV	S.C.C. No.2 Brown				71038			UA273		30097	76	35	
AK11386	AFV	S.C.C. No.15 Olive Drab				71016	H309		UA270			110	37	
AK11387	AFV	3B AU/ZB AU				71281						246	77	
AK11401	FIG	Base Flesh				70341					30233			AK3011
AK11402	FIG	Light Flesh									31433			AK3012
AK11403	FIG	Highlight Flesh				70342								AK3013
AK11404	FIG	Shadow Flesh									31136			AK3014
AK11405	FIG	Dark Shadow Flesh			73	982								AK3015
AK11406	FIG	Reddish Black									10049			AK3016
AK11407	FIG	Black Uniform Base				70306	C137		UA733		26061			AK3002
AK11408	FIG	Dot44 Brown Base												AK3021
AK11409	FIG	Orange Tan									32516			AK3022
AK11410	FIG	Dark Green												AK3023
AK11411	FIG	Light Green												AK3024
AK11412	FIG	Medium Green				70348	H303		UA002		34102			AK3025
AK11413	FIG	Denison Tan Base				70339					30227			AK3026
AK11414	FIG	Splittermuster Base				70332					33303			AK3041
AK11415	FIG	Splittermuster Green Spots									34095			AK3043
AK11416	FIG	Waffen Brown Grey												AK3051
AK11417	FIG	Waffen Brown				875					30045			AK3055
AK11418	FIG	Brown Black				70333								AK3056
AK11419	FIG	Waffen Red Brown			160	984				8011	30108			AK3061
AK11420	FIG	Waffen Green												AK3065
AK11421	FIG	Dark Olive Green									34094			AK3071
AK11422	FIG	Ocher Khaki			93	824					30266			AK3072
AK11423	FIG	Field Grey Base #2 (Grey Uniform)			79	867	68				36099			AK3142
AK11424	FIG	Grey Green									34424			AK3143
AK11425	FIG	Field Grey Base #1 (Green uniform)			75	897					34052			
AK11426	FIG	Grey Blue				70338								AK3146
AK11427	FIG	Green Uniform Base				70335					16165			AK3114
AK11428	FIG	Light Green Uniform				70336								AK3115
AK11429	FIG	Russian Uniform Lights									34258			AK3121
AK11430	FIG	Russian Uniform Base				70327					34098			AK3122
AK11431	FIG	Russian Blue Lights												AK3124
AK11432	FIG	Russian Blue Base				70309								AK3125
AK11433	FIG	US Olive Base Uniform												
AK11434	FIG	Red Brown				70343								AK3073
AK11435	FIG	Field Drab				873								AK3075
AK11436	FIG	Canvas Tone				988								AK3076
AK11437	FIG	British Uniform Base				70317					16160			AK3081
AK11438	FIG	British Uniform Lights				70321					20475			AK3082
AK11439	FIG	French Greyish Blue									35109			AK3101
AK11440	FIG	Desert Uniform Base												AK3111



3rd GENERATION ACRYLICS

3

METAL COLORS / COLORES METÁLICOS

3.1 XTREME METAL

Xtreme Metal is a high quality metallic range, developed with outstanding pigments, and specially formulated to give you the best results. Resistant to masking, any type of weathering, with ultra high coverage power, and fast drying. Now it's easy to clean your airbrush without leaving any pigment/paint debris. These are quite simply the highest quality metallic paints ever seen. This range also includes ultrafine high quality auto-leveling primers, with superb gripping force and durability.

Xtreme Metal es una gama metálica de alta calidad, desarrollada con pigmentos sobresalientes y especialmente formulada para brindarle los mejores resultados. Resistente al enmascaramiento, a cualquier tipo de envejecimiento, con una potencia de cobertura ultra alta y un secado rápido. Ahora es fácil limpiar su aerógrafo sin dejar residuos de pigmento / pintura. Estas son lacas metálicas de la más alta calidad que se hayan visto. Esta gama también incluye imprimadores autonivelantes de alta calidad ultrafinos, con excelente fuerza de agarre y durabilidad.



AK471
BLACK BASE

AK472
GOLD

AK473
COPPER



AK474
BRONZE

AK475
BRASS

AK476
STEEL

AK477
CHROME



AK478
WHITE ALUMINUM

AK479
ALUMINUM

AK480
DARK ALUMINUM

AK481
POLISHED ALUMINUM



AK482
DURALUMINUM

AK483
GUN METAL

AK484
BURNT METAL

AK485
PALE BURNT METAL



AK486
JET EXHAUST

AK487
BLUE ELECTRIC METAL

AK488
MATTE ALUMINUM

AK669
TITANIUM



AK670
STAINLESS STEEL

AK671
METALLIC SMOKE

AK672
PALE BRASS

AK674
METALLIC PURPLE



AK470
XTREME CLEANER AND THINNER

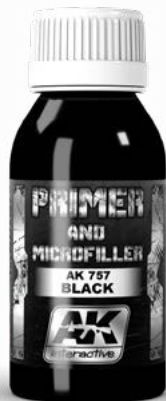

AK757
BLACK PRIMER AND
MICROFILLER



AK758
GREY PRIMER AND
MICROFILLER



AK759
WHITE PRIMER AND
MICROFILLER



3.2 TRUE METAL

A range of metallic paints created from a wax base. Made from high quality pigments, achieving extremely realistic effects. The basic product can be used in all branches of modeling, and it can be applied by brush, with the fingertip, or with a cotton swab. Once dried, it can be polished to achieve a metallic finish. *Una gama de pinturas metálicas creadas a partir de una base de cera. Fabricadas con pigmento y ceras de alta calidad, logrando efectos extremadamente realistas. El producto básico se puede utilizar en todas las ramas del modelismo y se puede aplicar con pincel, con la punta de los dedos o con un algodón. Una vez seco, se puede pulir para lograr un acabado metálico.*

AK450
GOLD



AK451
METALLIC BLUE



AK452
METALLIC PURPLE



AK453
OLD BRONZE



AK454
COPPER



AK455
ALUMINUM



AK456
DARK ALUMINUM



AK457
STEEL



AK458
SILVER



AK459
IRON



AK460
BRASS



AK461
GUN METAL



REAL COLORS

www.akrealcolors.com

by **AK**

www.ak-interactive.com

THE FUEL FOR MODELING



REAL ACRYLIC LACQUER

REAL COLOR ACCURACY



FORGET CLOGGING: REAL COLORS FLOW
SMOOOOOTHLY IN YOUR AIRBRUSH.



HOLDS FIRMLY ALL KIND OF WEATHERING AND
EXTRA EFFECTS.



FOR DILUTION, OUR REAL COLOR THINNER
WORKS REALLY GREAT..., BUT OTHERS TOO.



HIGHLY COMPATIBLE WITH OTHER ACRYLIC
LACQUER BRANDS.



YouTube

www.ak-interactive.com
Phone & Fax: (+34) 941 22 30 64
info@ak-interactive.com

OUR BRAND NEW PAINTS
REFILL YOUR DREAMS

4.

REAL COLORS / COLORES REALES

REAL COLORS STANDARD & AFV

THE ACCURACY

REAL COLORS AIRCRAFT

PROPERTIES / PROPIEDADES

Real Colors are a whole new range of state-of-art acrylic lacquer paints developed in our own laboratories. This has been a project we have been quietly planning, working and developing for a long time. Our main objective was to develop an improved chemical formula over other brands on the market. The result is that we can offer you the highest quality paints that accurately represent the original color tones, thanks to our cooperation with renowned experts on the subject of vehicle and aircraft colors.

Real Colors es una gama completamente nueva de lacas acrílicas de última generación desarrolladas en nuestros propios laboratorios. Este ha sido un proyecto que hemos estado planeando, trabajando y desarrollando silenciosamente durante mucho tiempo. Nuestro principal objetivo era desarrollar una fórmula química mejorada con respecto a otras marcas del mercado. El resultado es poder ofrecer pinturas de la más alta calidad que representan con máxima precisión los tonos de color originales, gracias a nuestra cooperación con renombrados expertos en el tema de los colores tanto de vehículos como aviones.



Forget clogging: Real Colors flow smoothly in your airbrush. Spraying is now a real pleasure and thanks to our new chemical formula, even if you dampen the surface too much, the paint levels out and dries with a nice matt finish.

Olvidate de los atascos: LOS COLORES REALES DE AK fluyen suavemente en tu aerógrafo. Aerografiar es ahora un gran placer gracias a nuestra nueva fórmula, incluso si encharcas la superficie, ya que la pintura se acaba estirando. Un acabado mate uniforme y perfecto.



For dilution, our Real Colors Thinner works superbly... but others also work, too. They can be diluted with our own specific thinner or ones from other brands and types: acrylic lacquer (non-vinyl), lacquer thinner, alcohol, etc.

Nuestros disolventes específicos funcionan de maravilla con los Colores Reales... pero los de otras marcas también funcionan. Las pinturas se pueden diluir con nuestro thinner específico, e incluso con los de otras marcas y tipos: para lacas acrílicas (no vinílicas), Lacquer Thinner, etc.



Real Colors will hold firmly all kinds of weathering and extra effects. Paint adheres and dries perfectly with a soft matt finish, so you can throw on it all of the treatments, punishment and weathering you love to create.

Soportan perfectamente todo tipo de efectos de envejecimiento. La pintura se adhiere perfectamente a la superficie con un acabado mate muy suave lo que permite aplicar sobre ella todo tipo de efectos de envejecimiento.



Real Colors are highly compatible with other acrylic lacquer brands. If lost on a forgotten island, you can easily mix Real Colors with the stock of paints from other brands you may have ;)

Altamente compatible con pinturas con base laca de otras marcas. Puedes mezclar las Pinturas Reales fácilmente con tu stock de pinturas de otras marcas que tengas ;)



**REAL
COLORS
STANDARD & AFV**

**REAL
COLORS
AIRCRAFT**



HOW TO USE THEM / CÓMO USARLAS

We are going to explain and demonstrate how to use Real Color paints to achieve the best results. This explanation is also valid for valid for any lacquer-type paint, such as Tamiya or Mr.Hobby.

Vamos a explicar y mostrar cómo se deben usar las pinturas Real Colors para obtener los mejores resultados. Esta explicación sería válida para cualquier pintura tipo laca, como Tamiya o Mr. Hobby.

Lacquers are professional paints with the best finishes, and specially developed for modelers. They have many advantages over other types of paints, but it is necessary to know their characteristics and use before painting.

Las lacas son pinturas profesionales con los mejores acabados y usabilidad, especialmente desarrolladas para modelistas. Tienen muchas ventajas sobre otro tipo de pinturas, pero se necesita conocer sus características antes de usarlas.

Our Real Colors have an advantage over other brands of paint, closely matching the original colors. We can therefore paint our models to represent true reality with maximum accuracy.

En el caso de los Real Colors también tienen la ventaja de que los tonos son exactos a los originales y por lo tanto podemos pintar nuestras maquetas y representar la realidad más auténtica y con la máxima precisión.



1

Tamiya and Mr. Hobby bottles have similar characteristics in terms of capacity and shape that allow quick identification of lacquer-like paints.

Los botes de Tamiya y Mr.Hobby tienen características similares en términos de capacidad y forma que permiten una rápida identificación de las pinturas tipo laca.



2

In terms of compatibility, do not use the lacquers with water or with thinners intended for vinyl-based acrylic paints. They simply will not work, or they will work incorrectly.

En lo que se refiere a compatibilidad, no useis las lacas con agua o con disolventes para pinturas acrílicas, tales como thinners acrílicos, disolvente de tamiya tapón blanco o disolvente de Mr Hobby para pinturas acrílicas, simplemente no funcionarán o lo harán de forma incorrecta.

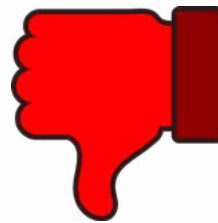

LACQUERS ARE NOT COMPATIBLE WITH:

- *WATER
- *ACRYLIC THINNERS
- *AK712/AK11500
- *TAMIYA WHITE CAP

LAS LACAS NO SON COMPATIBLES CON:

- *AGUA
- *DISOLVENTES ACRÍLICOS
- *AK712/AK11500
- *TAMIYA TAPÓN BLANCO



3

Real Colors can be diluted with thinners like Gaia, Tamiya 'yellow cap' thinner, Mr. Color Thinner or Levelling Thinner, Real Colors High Compatibility Thinner, or any other thinner intended for lacquers.

Se debe utilizar con diluyentes para lacas: como Gaia, Tamiya de tapón amarillo, disolvente para lacas Mr Color, Real Colors thinner o cualquier otro diluyente para lacas.



MAXIMUM COMPATIBILITY WITH:

- *LACQUER PAINTS OF ANY OTHER BRAND
- *TAMIYA YELLOW CAP
- *GAIA
- *MR. HOBBY
- *REAL COLORS THINNER

MÁXIMA COMPATIBILIDAD CON:

- *PINTURAS LACA DE CUALQUIER MARCA
- *TAMIYA TAPÓN AMARILLO
- *GAIA
- *MR. HOBBY
- *REAL COLORS THINNER



4

Real Colors are compatible with lacquer-based paints from different brands and you can make any combination you like.

La pintura tipo laca es perfectamente compatible entre las distintas marcas y puedes hacer las combinaciones que quieras.

- LACQUER PAINTS PROPERTIES:**
- *VERY EASY TO MIX
 - *HIGH RESISTANCE
 - *QUICK DRYING TIME
 - *NO CLOGGING IN THE AIR-BRUSH

- CARACTERÍSTICAS DE LAS LACAS:**
- *MUY FÁCIL DE MEZCLAR
 - *ALTA RESISTENCIA
 - *SECADO RÁPIDO
 - *NO SE ATASCA EN EL AERÓGRAFO



5

Let's now see how Real Colors High Compatibility Thinner will serve to dilute lacquer-based paints from different brands. As you can see, lacquers from all four brands behave perfectly.

Veamos ahora cómo todos los diluyentes para lacas servirán para diluirlas y dejarlas listas para usar con aerógrafo o pincel. Se comportan perfectamente las cuatro marcas.

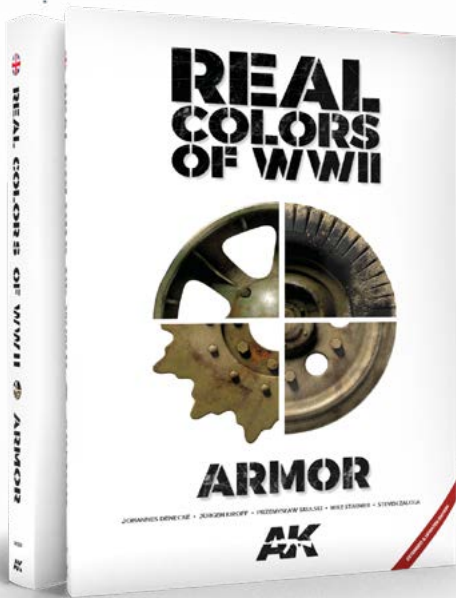

AK299

REAL COLORS OF WWII - NEW 2ND EXTENDED & UPDATED VERSION

This publication is an updated and extended edition of our book Real Colors of WWII released in 2017. It describes the camouflage development and colors of the German, Soviet, US and British army vehicles during WWII. The team of authors has been expanded: renowned German researcher Johannes Denecke is responsible for the revision of the German chapter. The Soviet and British chapters have also been updated by Przemyslaw Skulski and Mike Starmer, respectively. Real Colors of WWII Armor has a total of 228 pages and is profusely illustrated with 244 archive photos (inc. 54 in original color), 50 modern photographs of preserved artifacts, numerous color chips, several reproductions of original color samples, camouflage drawings and other documents, and 43 colour profiles of which more than half has been specially commissioned for this edition. This is the new definitive guide on the WWII AFV colors for the modellers, wargamers and armchair historians.

Esta publicación es una edición actualizada y extendida de nuestro libro Real Colors of WWII lanzado en 2017. Describe el desarrollo de camuflaje y los colores de los vehículos del ejército alemán, soviético, estadounidense y británico durante la Segunda Guerra Mundial. El equipo de autores se ha ampliado: el reconocido investigador alemán Johannes Denecke es responsable de la revisión del capítulo alemán. Los capítulos soviético y británico también han sido actualizados por Przemyslaw Skulski y Mike Starmer, respectivamente. Real Colors of WWII Armor tiene un total de 228 páginas y está profusamente ilustrado con 244 fotos de archivo (inc. 54 en color original), 50 fotografías modernas de artefactos conservados, numerosas fichas de colores, varias reproducciones de muestras de colores originales, dibujos de camuflaje y otros documentos y 43 perfiles de color de los cuales más de la mitad ha sido especialmente encargado para esta edición. Esta es la nueva guía definitiva sobre los colores AFV de la Segunda Guerra Mundial para modeladores, wargamers e historiadores de sillones.

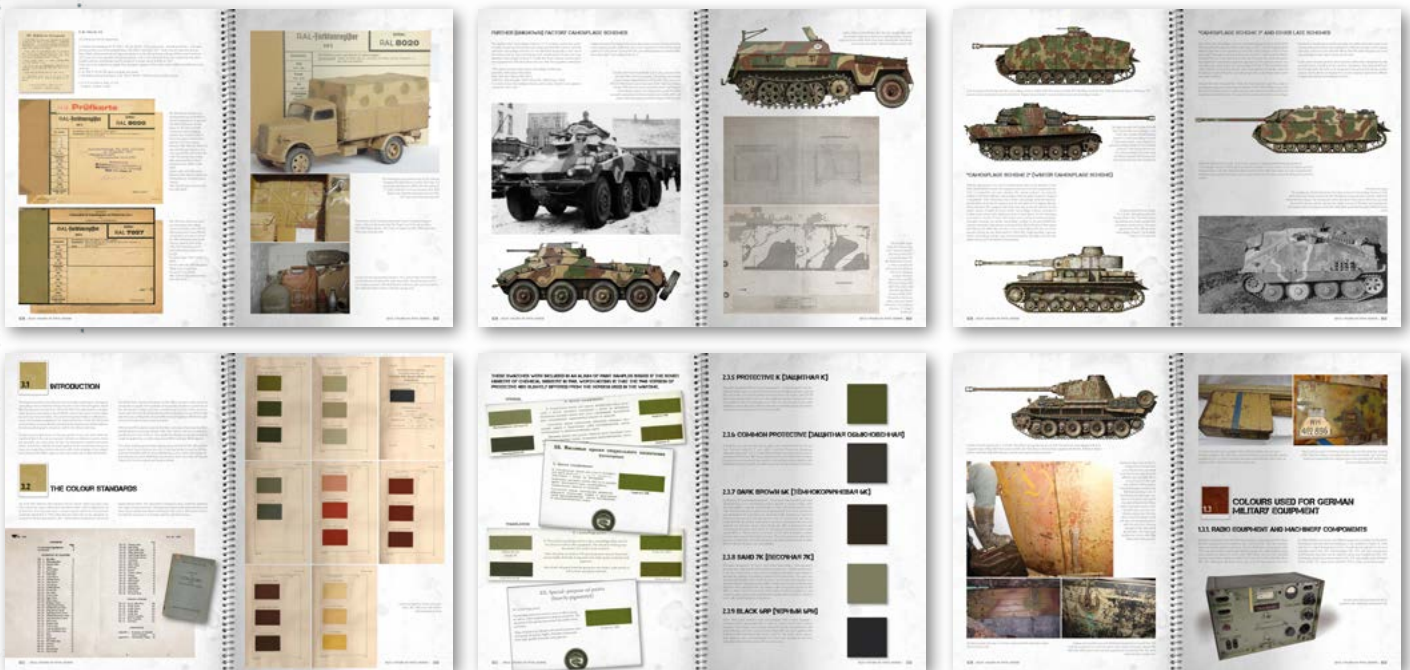

BASIC COLORS & VARNISHES / COLORES BÁSICOS, TRANSPARENTES Y BARNICES





RC502
GLOSS VARNISH



RC503
CLEAR RED



RC504
CLEAR BLUE



RC505
CLEAR GREEN



RC506
CLEAR ORANGE



RC507
CLEAR YELLOW



RC508
CLEAR SMOKE

AFV COLORS / COLORES DE VEHÍCULOS MILITARES



RC023
OLIVE DRAB
N°9 / N°22



RC024
OLIVE DRAB
FADED



RC025
DARK OLIVE
DRAB N°31



RC026
OLIVE DRAB
FS 34087



RC027
FOREST GREEN
FS 34079



RC028
INTERIOR GREEN
FS 34151



RC029
N°5 EARTH BROWN
FS 30099



RC030
N°6 EARTH YELLOW
FS 30257



RC031
N°8 EARTH RED
FS 30117



RC032
DESERT SAND
FS 30279



RC033
KHAKI GREEN
N°3



RC034
S.C.C. 1A BROWN



RC035
S.C.C. 2 BROWN



RC036
S.C.C. 14
BLUE BLACK



RC037
S.C.C. 15
OLIVE DRAB



RC038
BSC N°28
SILVER GREY



RC039
BSC N°34 SLATE



RC040
BSC N°61
LIGHT STONE



RC041
BSC N°64
PORTLAND STONE



RC042
BRITISH DARK OLIVE
GREEN PFI



RC043
BRITISH DESERT
PINK ZI



RC044
BRITISH
LIGHT MUD



RC045
BSC N°49 LIGHT
PURPLE BROWN



RC046
ELFBEIN - IVORY
RAL 1001
(INTERIOR COLOR)



RC047
OLIVGRÜN -
OLIVE GREEN RAL 6003



RC048
FELDGRAU -
FIELD GREY
RAL 6006



RC049
GRÜN - GREEN
RAL 6007



RC050
DUNKELGRÜN - DARK
GREEN RAL 6009



RC051
MARINEGRAU - NAVY
GREY RAL 7002



RC052
GRAU - GREY
RAL 7003



RC053
GRAUGRÜN - GRAY
GREEN RAL 7008



RC054
HELLGRAU - LIGHT
GREY RAL 7009
(INTERIOR COLOR)



RC055
BLAUGRAU - BLUE GRAY
RAL 7016



RC056
DUNKELBRAUN - DARK BROWN
RAL 7017



RC057
DUNKELGRAU - DARK
GRAY RAL 7021



RC058
GRAU - GRAY
RAL 7027



RC059
DUNKELGELB NACH
MUSTER - DARK
YELLOW



RC060
DUNKELGELB - DARK
YELLOW RAL 7028



RC061
DUNKELGELB AUSGABE
44 - DARK YELLOW
RAL 7028 VER. '44



RC062
DUNKELGELB - DARK
YELLOW (VARIANT)



RC063
GELBBRAUN - YELLOW
BROWN RAL 8000



RC064
ERDSELB - EARTH
YELLOW
RAL 8002



RC065
BRAUN - BROWN
RAL 8010



RC066
ROT (ROTBRAUN) -
RED (RED BROWN)
RAL 8013



RC067
ROT (ROTBRAUN)
RED (RED BROWN)
RAL 8012



RC068
ROTBRAUN - RED
BROWN RAL 8017



RC069
BRAUN - BROWN
RAL 8020



RC070
COMMON
PROTECTIVE - Z0



RC071
BLACK 6RP



RC072
PROTECTIVE K



RC073
PROTECTIVE 4B0



RC074
DARK BROWN 6K



RC075
SAND 7K



RC076
PROTECTIVE GREEN
1920S - 1930S



RC077
ZB AU BASIC
PROTECTOR



RC078
APC INTERIOR GREEN
FS 24533



RC079
CARC TAN 686A
FS 33446



RC080
NATO GREEN
RAL 6031-F9



RC081
NATO BROWN
RAL 8027-F9



RC082
NATO BLACK
RAL 9021-F9



RC083
GREEN FS 34102



RC084
SAND FS 30277



RC085
FIELD DRAB
FS 30118



RC086
GELBOLIV (INITIAL)
RAL 6014



RC087
GELBOLIV (LATE)
RAL 6014



RC088
SANDBEIGE
RAL 1039-F9



RC089
GRAUBEIGE - GREY
BEIGE RAL 1040-F9



RC090
HELLOLIV - LIGHT
OLIVE RAL 6040-F9



RC091
TARNGRAU
RAL 7050-F9



RC092
SANDBRAUN
RAL 8031-F9



RC093
BRITISH SAND
YELLOW



RC094
IDF MODERN GREY



RC095
IDF SAND GREY
1970S-1980S



RC096
IDF EARLY SAND
YELLOW



RC097
UAE SAND DULL



RC098
RUSSIAN MODERN
GREEN



RC099
RUSSIAN GREYISH
YELLOW



RC100
RUSSIAN GREY
GREEN



RC101
EGYPTIAN
DESERT SAND



RC102
SYRIAN REPUBLICAN
GUARD DESERT
YELLOW



RC103
LIBYAN ARMY
DESERT GREY



RC104
IRAQI ARMY
DESERT SAND



RC105
SPANISH GREEN

SETS



RCS001
GERMAN ARMY PRE-WWII COLORS
Included / Include: RC048 Feldgrau - Field Grey RAL 6006, RC049 Grün - Green RAL 6007, RC064 Erdgelb - Earth Yellow RAL 8002, RC065 Braun - Brown RAL 8010



RCS002
GERMAN ARMY EARLY WWII COLORS
Included / Include: RC056 Dunkelbraun - Dark Brown RAL 7017, RC057 Dunkelgrau - Dark Grey RAL 7021, RC002 Cream White RAL 9001



RCS003
AFRIKA KORPS COLORS
Included / Include: RC053 Graugrün - Grey Green RAL 7008, RC063 Gelbbraun - Yellow Brown RAL 8000, RC058 Grau - Grey RAL 7027, RC069 Braun - Brown RAL 8020



RCS004
GERMAN ARMY 1943-1945
Included / Include: RC047 Olivgrün - Olive Green RAL 6003, RC060 Dunkelgelb - Dark Yellow RAL 7028, RC068 Rotbraun - Red Brown RAL 8017



RCS005
GERMAN ARMY WWII INTERIOR COLORS
Included / Include: RC046 Elfenbein - Ivory RAL 1001, RC054 Hellgrau - Light Grey RAL 7009, RC066 Rot (Rotbraun) - Red (Red Brown) RAL 8013, RC067 Rot (Rotbraun) - Red (Red Brown) RAL 8012



RCS006
GERMAN ARMY DARK YELLOW 1943-1945
Included / Include: RC059 Dunkelgelb nach Muster, RC060 Dunkelgelb - Dark Yellow RAL 7028, RC061 Dunkelgelb Ausgabe 1944 - Dark Yellow 1944 Variant RAL 7028, RC062 Dunkelgelb - Dark Yellow (variation)



RCS007
WWII SOVIET AFV COLORS
Included / Include: RC072 Protective K, RC073 Protective 4B0, RC074 Dark Brown 6K, RC075 Sand 7K



RCS008
BRITISH ARMY EARLY & MID WWII VEHICLES
Included / Include: RC033 Khaki Green No.3, RC034 S.C.C. 1A Brown, RC035 S.C.C. 2 Brown, RC036 S.C.C. 14 Blue Black



RCS009

BRITISH ARMY LATE WWII VEHICLES

Included / Include: RC034 S.C.C. 1A Brown, RC036 S.C.C. 14 Blue Black, RC037 S.C.C. 15 Olive Drab



RCS010

BRITISH CAUNTER SCHEME

Included / Include: RC038 BSC No.28 Silver Grey, RC039 BSC No.34 Slate, RC040 BSC No.61 Light Stone, RC041 BSC No.64 Portland Stone



RCS011

BRITISH ARMY AFRICA, LATE 1942-1943

Included / Include: RC036 S.C.C. 14 Blue Black, RC040 BSC No.61 Light Stone, RC042 British Dark Olive Green PFI, RC043 British Desert Pink ZI



RCS012

BRITISH ARMY TUNISIA, SICILY, & ITALY 1943-1945

Included / Include: RC036 S.C.C. 14 Blue Black, RC037 S.C.C. 15 Olive Drab, RC042 British Dark Olive Green PFI, RC044 Light Mud



RCS013

WWII U.S. ARMY BASIC COLORS

Included / Include: RC001 Flat Black, RC023 Olive Drab No.9/No.22, RC024 Olive Drab Faded, RC030 Earth Yellow No.6



RCS014

WWII U.S. ARMY DISRUPTIVE CAMO PAINTS

Included / Include: RC028 Light Green, RC029 Earth Brown No.5, RC031 Earth Red No.8, RC032 Desert Sand



RCS015

IDF AFV COLORS

Included / Include: RC094 IDF Sinay Grey 1990, RC095 IDF Sinay Grey 1982, RC096 IDF Sinay Grey 1973



RCS016

RUSSIAN MODERN AFV

Included / Include: RC071 Black 6RP, RC098 Russian Modern Green, RC099 Russian Greyish Yellow, RC100 Russian Grey Green



RCS017

BUNDESWEHR BASIC DESERT COLORS

Included / Include: RC088 Sandbeige RAL 1039-F9, RC090 Helloliv - Light Olive RAL 6040-F9, RC091 Tarngrau - Camo Grey RAL 7050-F9, RC092 Sandbraun - Sand Brown RAL 8031-F9



RCS018

BUNDESWEHR EARLY & COMPLEMENTARY COLORS

Included / Include: RC086 Gelboliv Initial RAL 6014, RC087 Gelboliv Late RAL 6014, RC089 Graubeige - Grey Beige RAL 1040-F9



RCS019

U.S. ARMY MODERN VEHICLES

Included / Include: RC079 CARC Tan 686A (FS 33446), RC080 NATO Green, RC081 NATO Brown, RC082 NATO Black



RCS020

ARAB ARMOR DESERT COLORS

Included / Include: RC101 Egyptian Desert Sand, RC102 Syrian Rep. Guard Desert Yellow, RC103 Lybian Army Desert Grey, RC104 Iraqi Army Desert Sand



RCS021

NATO COLORS

Included / Include: RC080 NATO Green, RC081 NATO Brown, RC082 NATO Black



RCS022

BASIC CLEAR COLORS

Included / Include: RC503 Clear Red, RC505 Clear Green, RC506 Clear Orange



RCS023

COMPLEMENTARY CLEAR COLORS

Included / Include: RC504 Clear Blue, RC507 Clear Yellow, RC508 Clear Smoke



RCS071

AUSCAM COLORS (LIMITED EDITION)

Included / Include: RC106 Australian Green, RC107 Australian Tan, RC108 Australian Black

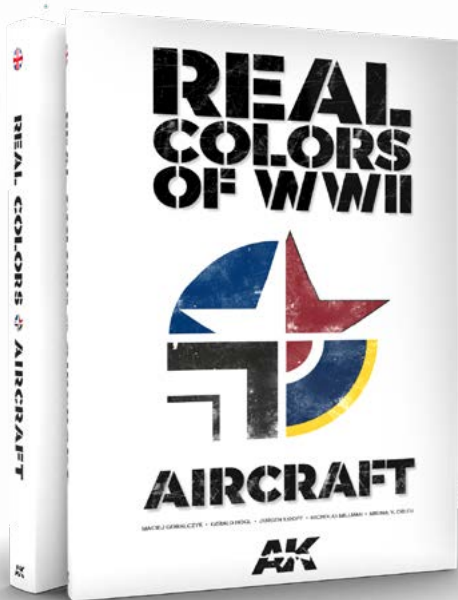

REAL COLORS AIRCRAFT

AK290 REAL COLORS OF WWII AIRCRAFT

The most up-to-date reference book on the aircraft colors of the main WWII adversaries: Germany, United States, Great Britain and Soviet Union. A comprehensive guide to the colors and camouflage schemes, presented on 292 pages and illustrated with 42 color profiles, several document reprints, and 390 b/w and color photos, many of which are very rare. Included is the latest information on the Luftwaffe's late war colors, which have been reproduced as scale colors on the basis of the original paint factory recipes by Gerald T. Högl and Jürgen Kiroff. For the very first time, the unparalleled research on the Soviet Air Force colors done by Mikhail V. Orlov is introduced to the non-Russian readers. Nicholas Millman's archival research brings us accurate reproduction and description of the colors used by the USAAF, US Navy and RAF/FAA.

El libro de referencia más actualizado sobre los colores de los aviones de los principales adversarios de la Segunda Guerra Mundial: Alemania, Estados Unidos, Gran Bretaña y la Unión Soviética. Una guía completa de los colores y esquemas de camuflaje, presentada en 292 páginas e ilustrada con 42 perfiles de color, varias reproducciones de documentos originales y 390 fotos en color y blanco y negro, muchas de las cuales son inéditas. Se incluye la información más reciente sobre los colores tardíos de la Luftwaffe, que se han reproducido como colores de escala en base a las fórmulas originales de la fábrica de pinturas de Gerald T. Högl y Jürgen Kiroff. Por primera vez una investigación sin precedentes sobre los colores de la Fuerza Aérea Soviética realizada por Mikhail V. Orlov se presenta a los lectores no rusos. La investigación de archivos de Nicholas Millman nos brinda una reproducción y descripción precisa de los colores utilizados por la USAAF, la US Navy y la RAF / FAA.

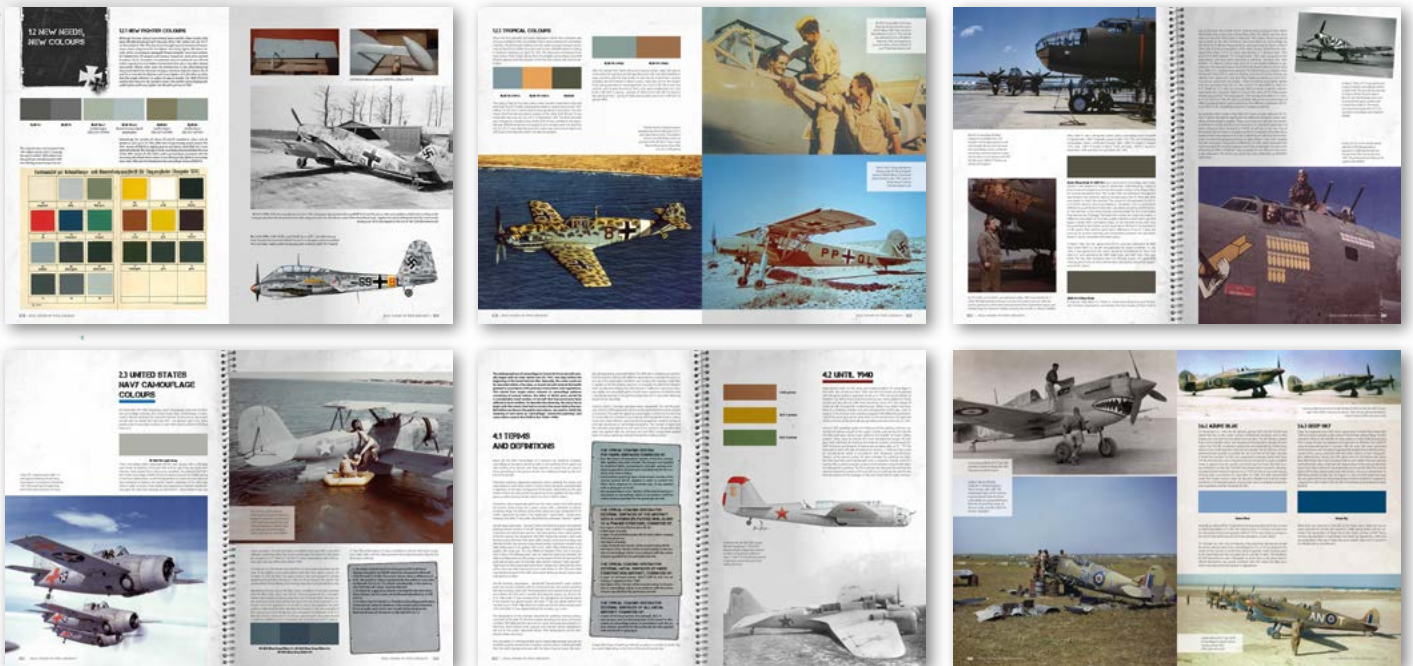



RC230
DULL DARK GREEN
FS 34092



RC231
FIELD GREEN
FS 34097



RC232
PALE GREEN
FS 34227



RC233
GREEN FS 34258



RC234
AGGRESSOR BLUE
FS 35109



RC235
INTERMEDIATE BLUE
FS 35164



RC236
BLUE FS 35190



RC237
MEDIUM GREY FS
35237



RC238
LIGHT BLUE FS 35414



RC239
AIR SUPERIORITY
BLUE FS 35450



RC240
LIGHT SKY BLUE
FS 35526



RC241
DUCK EGG BLUE
FS 35622



RC242
DARK EGGPLANT GREY
FS 36076



RC243
GREY FS 36081



RC244
MEDIUM GUNSHIP
GREY FS 36118



RC245
HAVE GLASS GREY



RC246
F-15 DARK GREY (MOD
EAGLE) FS 36176



RC247
DARK GULL GREY
FS 36231



RC248
AGGRESSOR
GREY FS 36251



RC249
MEDIUM GREY
FS 36270



RC250
LIGHT SEA GREY FS
36307



RC251
DARK GHOST GREY
FS 36320



RC252
LIGHT GHOST GREY
FS 36375



RC253
LIGHT GREY
FS 36495



RC254
CAMOUFLAGE GREY
FS 36622



RC255
M-485 LIGHT GREY



RC256
M-485 BLUE
GREY



RC257
SEA BLUE



RC258
DARK SEA BLUE



RC259
DARK OLIVE DRAB 41



RC260
MEDIUM GREEN 42



RC261
NEUTRAL GREY 43



RC262
US INTERIOR YELLOW
GREEN



RC263
ZINC CHROMATE
YELLOW



RC264
BRONZE GREEN



RC265
RLM 02 RLM-GRAU
(1938)



RC266
RLM 02 RLM-GRAU
(1941)



RC267
RLM 04



RC268
RLM 61



RC269
RLM 62



RC270
RLM 63



RC271
RLM 65 (1938)



RC272
RLM 65 (1941)



RC273
RLM 66 (1941)



RC274
RLM 70



RC275
RLM 71



RC276
RLM 72



RC277
RLM 73



RC278
RLM 74



RC279
RLM 75



RC280
RLM 78 (1941)



RC281
RLM 78 (1942)



RC282
RLM 79 (1941)



RC283
RLM 79 (1942)



RC284
RLM 80



RC285
RAF SKY GREY /
FS 26373



RC286
RAF DARK GREEN



RC287
RAF DARK EARTH



RC288
RAF OCEAN
GREY



RC289
RAF MEDIUM SEA GREY
BS381C/637



RC290
RAF SKY / FS 34424



RC291
RAF AZURE BLUE



RC292
RAF MIDDLE STONE



RC293
RAF COCKPIT
GREY-GREEN



RC294
RAF DARK
SLATE GREY



RC295
RAF EXTRA DARK
DARK SEA GREY
BS381C/640



RC296
RAF DARK SEA GREY
BS381C/638



RC297
RAF PRU BLUE
BS381C/636



RC298
RAF LIGHT AIRCRAFT
GREY BS381C/627



RC299
RAF CAMOUFLAGE (BARLEY) GREY
BS381C/626



RC300
RAF DARK CAMOUFLAGE GREY
BS381C/629



RC301
RAF CAMOUFLAGE BEIGE (HEMP)
BS 381C/389



RC302
IJN J3 HAI-IRO (GREY)



RC303
IJN J3 SP (AMBER GREY)



RC304
IJN D1 DEEP GREEN BLACK



RC305
IJN D2 GREEN BLACK



RC306
IJN M3 (M) MITSUBISHI INTERIOR GREEN



RC307
IJN M3 (N) NAKAJIMA INTERIOR GREEN



RC308
AE-9 / AII LIGHT GREY



RC309
AII GREEN



RC310
AII LIGHT BLUE



RC311
A-18F LIGHT GREY-BLUE



RC312
A-19F GRASS GREEN



RC313
AMT-1 LIGHT BROWN



RC314
A-21M LIGHT YELLOW-ISH BROWN



RC315
AMT-4 / A-24M GREEN



RC316
AMT-7 LIGHT BLUE



RC317
AMT-11 BLUE GREY



RC318
AMT-12 DARK GREY



RC319
A-14 INTERIOR STEEL GREY



RC320
RLM 76 VERSION 1



RC321
RLM 76 VERSION 2



RC322
RLM 76 LATE WAR VARIATION



RC323
RLM 81 VERSION 1



RC324
RLM 81 VERSION 2



RC325
RLM 81 VERSION 3



RC326
RLM 82



RC327
RLM 83



RC328
IJA #1 HAIRYOKUSHOKU (GREY-GREEN)



RC329
IJA #3 HAIRANSHOKU (GREY INDIGO)



RC330
IJA #7 OHRYUKO NANO GO SHOKU (OLIVE BROWN)



RC331
IJA #21 MIDORI IRO (GREEN)



RC332
IJA #27 AO MIDORI IRO (BLUE-GREEN)



RC333
IJA #29 KI MIDORI IRO (YELLOW-GREEN)



RC334
IJA #30 KAREKUSA IRO (DRY GRASS COLOUR)



RC335
IJA #31 CHA KASSHOKU (TEA COLOUR)



RC336
MIG-25/MIG-31 GREY



RC337
MIG-29 LIGHT GREY



RC338
MIG-29 GREY GREEN



RC339
RLM 66 (1938)



RC340
KENTTÄVIHREA-OLIVE GREEN FS 34096



RC341
SCHWARZGRAU-BLACK GREY RAL 7021



RC342
DARK GREEN FS 34064



AIRCRAFT SETS



RCS024

WW2 US NAVY & USMC AIRCRAFT EARLY COLORS

Included / Incluye: RC255 M-485 Light Grey, RC256 M-485 Blue-Grey, RC264 Bronze Green



RCS025

WW2 US NAVY & USMC AIRCRAFT LATE COLORS

Included / Incluye: RC222 Insignia White, RC235 Intermediate Blue, RC257 Sea Blue, RC258 Dark Sea Blue



RCS026

WW2 US ARMY AIR FORCE COLORS

Included / Incluye: RC259 Dark Olive Drab 41, RC260 Medium Green 42, RC261 Neutral Grey 43



RCS027

WW2 US AIRCRAFT INTERIOR COLORS

Included / Incluye: RC230 Dull Dark Green, RC262 US Interior Yellow Green, RC263 Zinc Chromate Yellow, RC264 Bronze Green



RCS028

LUFTWAFFE PRE-WW2 CAMOUFLAGE COLORS

Included / Incluye: RC268 RLM 61, RC269 RLM 62, RC270 RLM 63, RC271 RLM 65 (1938)



RCS029

LUFTWAFFE EARLY WW2 COLORS

Included / Incluye: RC265 RLM 02 RLM-Grau (1938), RC271 RLM 65 (1938), RC274 RLM 70, RC275 RLM 71



RCS030

LUFTWAFFE WW2 SEAPLANE COLORS

Included / Incluye: RC272 RLM 65 (1941), RC276 RLM 72, RC277 RLM 73, RC327 RLM 83



RCS031

LUFTWAFFE FIGHTER COLORS 1941-1944

Included / Incluye: RC278 RLM 74, RC279 RLM 75, RC320 RLM 76 Version 1, RC321 RLM 76 Version 2



RCS032

LUFTWAFFE TROPICAL COLORS 1941

Included / Incluye: RC280 RLM 78 (1941), RC282 RLM 79 (1941), RC284 RLM 80



RCS033

LUFTWAFFE TROPICAL COLORS 1942-1944

Included / Incluye: RC281 RLM 78 (1942), RC283 RLM 79 (1942), RC284 RLM 80



RCS034

LUFTWAFFE LATE WW2 COLORS

Included / Incluye: RC321 RLM 76 Version 2, RC322 RLM 76 Late War Variation, RC325 RLM 81 Version 3, RC326 RLM 82



RCS035

SOVIET SHTURMOVIK AND BOMBER COLORS 1943-1945 (MIXED CONSTRUCTION)

Included / Incluye: RC313 AMT-1 Light Brown, RC315 AMT-4 Green, RC316 AMT-7 Light Blue, RC318 AMT-12 Dark Grey



RCS036

SOVIET FIGHTER COLORS 1943-1945

Included / Incluye: RC316 AMT-7 Light Blue, RC317 AMT-11 Blue Grey, RC318 AMT-12 Dark Grey, RC319 A-14 Interior Steel Grey



RCS037

WW2 IJN AIRCRAFT COLORS

Included / Incluye: RC302 IJN J3 Hai-Iro (Grey), RC303 IJN J3 SP (Amber Grey), RC304 IJN D1 Deep Green Black, RC305 IJN D2 Green Black



RCS038

WW2 RAF TEMPERATE LAND SCHEME

Included / Incluye: RC286 RAF Dark Green, RC287 RAF Dark Earth, RC290 RAF Sky



RCS039

WW2 RAF DAY FIGHTER SCHEME

Included / Incluye: RC286 RAF Dark Green, RC288 RAF Ocean Grey, RC289 RAF Medium Sea Grey



RCS040

WW2 RAF DESERT COLORS

Included / Include: RC287 RAF Dark Earth, RC291 RAF Azure Blue, RC292 RAF Middle Stone



RCS041

WW2 RAF SEAC AIRCRAFT COLORS

Included / Include: RC286 RAF Dark Green, RC287 RAF Dark Earth, RC289 RAF Medium Sea Grey, RC291 RAF Azure Blue



RCS042

WW2 RAF / FAA TEMPERATE SEA SCHEME

Included / Include: RC285 RAF Sky Grey, RC290 RAF Sky, RC294 RAF Dark Slate Grey, RC295 RAF Extra Dark Sea Grey



RCS043

RAF FIGHTERS 1950S

Included / Include: RC286 RAF Dark Green, RC296 RAF Dark Sea Grey, RC297 RAF PRU Blue



RCS044

RAF V-BOMBER COLORS 1960S

Included / Include: RC222 White, RC286 RAF Dark Green, RC289 RAF Medium Sea Grey



RCS045

RAF FIGHTERS & V-BOMBERS 1970S

Included / Include: RC286 RAF Dark Green, RC296 RAF Dark Sea Grey, RC298 RAF Light Aircraft Grey



RCS046

US NAVY & USMC COLORS 1950S-1970S

Included / Include: RC258 Dark Sea Blue, RC220 Light Gull Grey FS 16440, RC222 Insignia White FS 17875, RC231 Field Green FS 34097



RCS047

USAF TAC SOUTH EAST ASIA (SEA) SCHEME

Included / Include: RC027 Forest Green FS 34079, RC083 Green FS 34102, RC225 Dark Tan FS 30219, RC254 Camouflage Grey FS 36622



RCS048

USAF EUROPEAN CAMO COLORS 1980S

Included / Include: RC027 Forest Green FS 34079, RC083 Green FS 34102, RC230 Dull Dark Green FS 34092, RC243 Grey FS 36081



RCS049

US MODERN AIRCRAFT GREYS 1980S-PRESENT

Included / Include: RC244 Medium Gunship Grey FS 36118, RC249 Medium Grey FS 36270, RC251 Dark Ghost Grey FS 36320, RC252 Light Ghost Grey FS 36375



RCS050

ISRAELI AF EARLY COLORS

Included / Include: RC208 Graublau - Grey Blue RAL 5008, RC217 Seidengrau - Silk Grey RAL 7044, RC218 Olivbraun - Olive Brown RAL 8008, RC219 MNO 2036 Small Khaki Avion



RCS051

ISRAELI AF EARLY DESERT COLORS

Included / Include: RC225 Dark Tan FS 30219, RC226 Sand FS 33531, RC232 Pale Green FS 34227, RC241 Duck Egg Blue FS 35622



RCS052

ISRAELI AF MODERN DESERT COLORS

Included / Include: RC225 Dark Tan FS 30219, RC226 Sand FS 33531, RC252 Light Ghost Grey FS 36375, RC290 FS 34424



RCS053

LUFTWAFFE COLORS 1960S-1970S

Included / Include: RC087 Gelboliv (Late) RAL 6014, RC207 Leuchtorange - Luminous Orange RAL 2005, RC210 Silbergrau - Silver Grey RAL 7001, RC212 Basaltgrau - Basalt Grey RAL 7012



RCS054

FAA (FALKLANDS/MALVINAS) 1970S-1990S

Included / Include: RC027 Forest Green FS 34079, RC083 Green FS 34102, RC225 Dark Tan FS 20400, RC224 Brown FS 30140, RC254 Camouflage Grey FS 36622



RCS055

SPANISH AIR FORCE (LAGARTO CAMO)

Included / Include: RC027 Forest Green FS 34079, RC223 Tan FS 20400, RC224 Brown FS 30140, RC254 Camouflage Grey FS 36622



RCS056

RCAF CF-18 HORNET COLORS

Included / Incluye: RC237 Medium Grey FS 35237, RC244 Medium Gunship Grey FS 36118, RC252 Light Ghost Grey FS 36375



RCS057

FORÇA AÉREA PORTUGUESA I

Included / Incluye: RC027 Forest Green FS34079, RC083 Green FS34102, RC225 Dull Dark Green FS30219, RC254 Camouflage Grey FS36622



RCS058

FORÇA AÉREA PORTUGUESA II

Included / Incluye: RC244 Medium Gunship Grey FS 36118, RC249 Medium Grey FS 36270, RC251 Dark Ghost Grey FS 36320, RC252 Light Ghost Grey FS 36375



RCS059

AERONÁUTICA MILITAR I

Included / Incluye: RC286 RAF Dark Green, RC288 RAF Ocean Grey, RC289 RAF Medium Sea Grey



RCS060

AERONÁUTICA MILITAR II

Included / Incluye: RC286 RAF Dark Green, RC287 RAF Dark Earth, RC290 RAF Sky



RCS061

LUFTWAFFE WW2 INTERIOR COLORS

Included / Incluye: RC265 RLM 02 RLM-Grau (1938), RC266 RLM 02 RLM-Grau (1941), RC273 RLM 66 (1941), RC339 RLM 66 (1938)



RCS062

WW2 FINNISH AIR FORCE COLORS

Included / Incluye: RC071 Musta - Black, RC220 Vaaleanharmaa - Light Grey (FS 16440), RC271 DN-Väri - DN-Light Blue (RLM 65), RC340 Kenttävihreä - Olive Green (FS 34096)



RCS063

LUFTWAFFE COLORS 1990S-2000S

Included / Incluye: RC213 Steingrau - Stone Grey RAL 7030, RC237 Medium Grey FS 35237, RC251 Dark Ghost Grey FS 36320, RC252 Light Ghost Grey FS 36375



RCS064

LUFTWAFFE NORM 83 SCHEME

Included / Incluye: RC027 Forest Green FS 34079, RC209 Olive Green RAL 6003, RC341 Schwarzgrau - Black Grey RAL 7021 (Modern)



RCS065

MARINEFLIEGER NORM 76 AND 87 SCHEMES

Included / Incluye: RC208 Graublau - Grey Blue RAL 5008, RC211 Grüngrau - Green Grey RAL 7009 (Modern), RC212 Basaltgrau - Basalt Grey RAL 7012, RC214 Lichtgrau - Light Grey RAL 7035



RCS066

USAF ASIA MINOR SCHEME

Included / Incluye: RC027 Forest Green FS 34079, RC223 Tan FS 20400, RC224 Brown FS 30140, RC254 Camouflage Grey FS 36622



RCS067

MODERN HELLENIC AIR FORCE GHOST SCHEME

Included / Incluye: RC237 Medium Grey FS 35237, RC248 Aggressor Grey FS 36251, RC250 Light Sea Grey FS 36307, RC251 Dark Ghost Grey FS 36320



RCS068

BELGIAN AIR FORCE COLORS 1950S-1970S

Included / Incluye: RC286 RAF Dark Green, RC289 RAF Medium Sea Grey BS381C/637, RC296 RAF Dark Sea Grey BS381C/638, RC297 RAF PRU Blue BS381C/636



RCS069

BELGIAN AIR FORCE COLORS 1970S-1990S

Included / Incluye: RC083 Green FS 34102, RC225 Dark Tan FS 30219, RC254 Camouflage Grey FS 36622, RC342 Dark Green FS 34064



RCS070

BELGIAN AIR FORCE COLORS 1990S-2000S

Included / Incluye: RC027 Forest Green FS 34079, RC244 Medium Gunship Grey FS 36118, RC249 Medium Grey FS 36270, RC252 Light Ghost Grey FS 36375

Ref.	Name	BS / FS / RAL	Mr. Hobby (GSI)	Tamiya	Vallejo	Hataka	Humbrol	Model Master	Lifecolor
RC001	Flat Black	RAL 9005 (Modern RAL 840 HR)	C33 / H12	XF-1	71.057	HTK_100	33	1749 / 4768	LC02
RC002	Cream White	RAL 9001 (Modern RAL 840 HR)	-	-	71.270	HTK_307	-	-	-
RC003	White Grey	RAL 9002 (Modern RAL 840 HR)	-	-	71.119	-	-	-	-
RC004	Flat White	RAL 9003 (Modern RAL 840 HR)	C62 / H11	XF-2	71.001	-	34	1768 / 4769	LC01
RC005	Signal Red	RAL 3020 (Modern RAL 840 HR)	C79 / H23	-	71.003	HTK_103	238	-	-
RC006	Red	RAL 3000 (Modern RAL 840 HR)	H13	XF-7	71.269	HTK_132	19	2733	LC06
RC007	Yellow	RAL 1003 (Modern RAL 840 HR)	C329 / H329	X-8	71.135	HTK_107	-	-	-
RC008	Maize Yellow	RAL 1006 (Modern RAL 840 HR)	H34	-	71.033	-	-	-	-
RC009	Orange	RAL 2004 (Modern RAL 840 HR)	C59 / H14	X-6	71.083	HTK_704	18	-	LC05
RC010	Pure Blue	RAL 5005 (Modern RAL 840 HR)	-	-	70.930	HTK_102	25	-	-
RC011	Blue	RAL 5001 (Modern RAL 840 HR)	-	-	-	-	-	-	-
RC012	Pure Green	RAL 6037 (Modern RAL 840 HR)	-	-	-	-	-	-	-
RC013	Off White	-	C69 / H21	-	-	-	-	4874	-
RC014	Buff	-	C336 / H336	XF-57	-	HTK_262	168	-	-
RC015	Gun Metal (Metallic)	-	C78 / H28	X-10	71.073	HTK_106	201	1795 / 4681	LC26
RC016	Ochre	-	-	-	-	-	-	-	LC64
RC017	Pale Blue	-	-	-	-	-	-	-	-
RC018	Pale Sand	-	-	-	70.837	-	-	-	-
RC019	Deck Tan	-	C321 / H321	XF-55	-	-	-	-	-
RC020	Aluminium (Metallic)	-	-	XF-16	71.062	HTK_078	56	1781 / 4677	LC24
RC021	Pale Grey	-	-	-	-	-	-	-	-
RC022	Rubber Black	-	C137 / H77	XF-85	71.315	-	-	1583	UA733
RC023	Olive Drab No.9 / No.22	☺	C12 / H52	-	-	HTK_018	-	2050 / 4842	-
RC024	Olive Drab Faded	☺	-	-	-	-	-	-	UA003
RC025	Dark Olive Drab No.31	☺	-	-	-	-	-	-	-
RC026	Olive Drab	☺ FS 34087	C304 / H304	-	71.043	HTK_065	155	1711 / 4728	UA523
RC027	Forest Green	☺ HH FS 34079	C309 / H309	XF-65	71.294	HTK_016	116	1710 / 4726	UA001
RC028	Interior Green	☺ HH FS 34151	C351 / H58	-	71.137	HTK_211	-	1715 / 4736	UA004
RC029	No.5 Earth Brown	☺ FS 30099	-	-	71.290	HTK_256	-	-	UA087
RC030	No.6 Earth Yellow	☺ FS 30257	-	-	71.291	HTK_212	63	-	UA081
RC031	No.8 Earth Red	☺ HH FS 30117	C43 / H37	-	71.293	HTK_213	186	1701 / 4707	UA306
RC032	Desert Sand	☺ FS 30279	H346	-	71.140	HTK_068	250	2053	UA089
RC033	Khaki Green No.3	☺	-	-	71.330	HTK_064	-	-	-
RC034	S.C.C. 1A Brown	☺	-	-	71.039	HTK_077	-	-	UA274
RC035	S.C.C. 2 Brown	☺	-	-	71.038	HTK_076	-	-	UA273
RC036	S.C.C. 14 Blue Black	☺	-	-	-	-	-	-	UA271
RC037	S.C.C. 15 Olive Drab	☺	-	-	71.016	HTK_110	-	-	UA270
RC038	BSC No.28 Silver Grey	☺	-	-	71.401	-	-	-	UA264
RC039	BSC No.34 Slate	☺	-	-	71.012	-	-	-	UA265
RC040	BSC No.61 Light Stone	☺	-	-	71.143	-	-	-	UA266
RC041	BSC No.64 Portland Stone	☺	-	-	71.288	-	-	-	UA267
RC042	British Dark Olive Green PFI	☺	-	-	-	-	-	-	UA269
RC043	British Desert Pink ZI	☺	-	-	71.400	-	-	-	UA268
RC044	British Light Mud	☺	-	-	71.284	-	-	-	UA272
RC045	BSC No.49 Light Purple Brown	☺	-	-	71.402	-	-	-	-
RC046	Elfenbein – Ivory	☺ RAL 1001	-	-	71.075	HTK_184	-	2104 / 4805	-
RC047	Olivgrün – Olive Green	☺ RAL 6003	H405	-	71.092	HTK_169	-	2149 / 4862	UA206
RC048	Feldgrau – Field Grey	☺ RAL 6006	-	-	71.268	HTK_151	-	2148 / 4860	-
RC049	Grün – Green	☺ RAL 6007	-	-	71.019	HTK_298	-	-	-
RC050	Dunkelgrün – Dark Green	☺ RAL 6009	-	-	-	-	-	-	-
RC051	Marinegrau – Navy Grey	☺ RAL 7002	-	-	-	-	-	-	-
RC052	Grau – Grey	☺ RAL 7003	-	-	-	-	-	-	-
RC053	Graugrün – Grey Green	☺ RAL 7008	-	-	71.116	HTK_304	-	2098	UA212
RC054	Hellgrau – Light Grey	☺ RAL 7009	-	-	-	-	-	-	UA233
RC055	Blaugrau – Blue Grey	☺ RAL 7016	-	-	71.115	HTK_300	-	2101	UA208
RC056	Dunkelbraun – Dark Brown	☺ RAL 7017	-	-	-	-	-	-	UA210
RC057	Dunkelgrau – Dark Grey	☺ RAL 7021	H401	XF-63	71.056	HTK_164	67	2094 / 4795	UA207
RC058	Grau – Grey	☺ RAL 7027	H404	-	71.118	HTK_306	-	2103	UA202
RC059	Dunkelgelb nach Muster	☺	-	-	-	HTK_310	-	-	-
RC060	Dunkelgelb – Dark Yellow	☺ RAL 7028	H403	XF-60	71.025	HTK_244	-	2095 / 4796	UA204

Ref.	Name	BS / FS / RAL	Mr. Hobby (GSI)	Tamiya	Vallejo	Hataka	Humbrol	Model Master	Lifecolor
RC061	Dunkelgelb Ausgabe 1944 – Dark Yellow 1944 Variant	RAL 7028	-	-	-	HTK_250	-	-	-
RC062	Dunkelgelb – Dark Yellow (variation)	RAL 7028	-	-	-	-	-	-	-
RC063	Gelbraun – Yellow Brown	RAL 8000	-	-	71.272	HTK_303	-	2099	UA203
RC064	Erdgelb – Earth Yellow	RAL 8002	-	-	71.420	HTK_297	-	2100	UA209
RC065	Braun – Brown	RAL 8010	-	-	71.038	HTK_299	-	-	-
RC066	Rot (Rotbraun) – Red (Red Brown)	RAL 8013	-	-	-	-	-	2165	-
RC067	Rot (Rotbraun) – Red (Red Brown)	RAL 8012	C43 / H47	-	71.271	HTK_175	-	2152 / 4861	UA211
RC068	Rotbraun – Red Brown	RAL 8017	H406	XF-9	71.041	HTK_147	160	2096 / 4797	UA205
RC069	Braun – Brown	RAL 8020	H402	-	71.117	HTK_305	-	2102	UA201
RC070	Common Protective Z0	-	-	-	-	HTK_316	-	-	-
RC071	Black 6RP	-	-	-	-	HTK_041	-	-	-
RC072	Protective K	-	C511	-	-	-	-	-	-
RC073	Protective 4B0	-	C512	-	71.017	HTK_251	-	-	-
RC074	Dark Brown 6K	-	-	-	71.282	HTK_317	-	-	-
RC075	Sand 7K	-	-	-	71.283	HTK_318	-	-	UA242
RC076	Protective Green 1920s – 1930s	-	-	-	-	-	-	-	-
RC077	ZB AU Basic Protector	-	-	-	71.281	HTK_246	-	-	-
RC078	APC Interior Green	FS 24533	-	XF-21	-	HTK_239	23	-	-
RC079	CARC Tan 686A	FS 33446	-	-	71.122	HTK_238	-	2136 / 4812	-
RC080	NATO Green	RAL 6031-F9	C519	XF-67	71.250	HTK_152	-	2173	UA303
RC081	NATO Brown	RAL 8027-F9	C520	XF-68	71.249	HTK_188	-	2174	UA302
RC082	NATO Black	RAL 9021-F9	C521	XF-69	71.251	HTK_125	-	-	UA301
RC083	Green	FS 34102	C303 / H303	-	71.289	HTK_021	117	1713 / 4734	UA002
RC084	Sand	FS 30277	-	-	71.138	HTK_210	187	4711	UA019
RC085	Field Drab	FS 30118	C55 / H81	-	71.139	HTK_209	-	1702 / 4708	UA016
RC086	Gelboliv Initial	RAL 6014	-	-	-	-	-	-	-
RC087	Gelboliv Late	RAL 6014 (Modern RAL 840 HR)	-	-	-	HTK_193	-	2175	-
RC088	Sandbeige	RAL 1039-F9	-	-	71.244	HTK_278	-	-	-
RC089	Graubeige – Grey Beige	RAL 1040-F9	-	-	71.245	HTK_279	-	-	-
RC090	Helloliv – Light Olive	RAL 6040-F9	-	-	71.247	HTK_281	-	-	-
RC091	Tamgrau – Camo Grey	RAL 7050-F9	-	-	71.248	HTK_089	-	-	-
RC092	Sandbraun – Sand Brown	RAL 8031-F9	-	-	71.246	HTK_280	-	-	-
RC093	British Sand Yellow	-	-	-	-	-	-	2137 / 4813	-
RC094	IDF Sinai Grey since 1990	-	C530	-	-	-	-	2138	-
RC095	IDF Sinai Grey 1982	-	C529	-	71.142	-	-	-	UA902
RC096	IDF Sinai Grey 1973	-	C528	-	71.141	-	-	-	UA020
RC097	UAE Dull Sand	-	-	-	-	-	-	-	-
RC098	Russian Modern Green	-	-	-	-	-	-	-	-
RC099	Russian Greyish Yellow	-	-	-	-	-	-	-	-
RC100	Russian Grey Green	-	-	-	-	-	-	-	-
RC101	Egyptian Desert Sand	-	-	-	-	-	-	-	-
RC102	Syrian Rep. Guard Desert Yellow	-	-	-	-	-	-	-	-
RC103	Libyan Army Desert Grey	-	-	-	-	-	-	-	-
RC104	Iraqi Army Desert Sand	-	-	-	-	-	-	-	-
RC105	Spanish Green	-	-	-	-	-	-	-	-
RC206	Russian Cockpit Torquise	-	C391	-	71.331	HTK_047	-	2135	-
RC207	Leuchtorange – Luminous Orange	RAL 2005 (Modern RAL 840 HR)	H98	-	71.082	HTK_194	-	-	LC23
RC208	Graublau – Grey Blue	RAL 5008 (Modern RAL 840 HR)	C14 / H54	-	71.005	HTK_171	-	-	-
RC209	Olive Green / USMC Green	RAL 6003 (Modern RAL 840 HR) / FS 34095	-	-	-	HTK_059	-	1786	-
RC210	Silbergrau – Silver Grey	RAL 7001 (Modern RAL 840 HR)	-	-	-	HTK_189	-	2160	-
RC211	Grüngrau – Green Grey	RAL 7009 (Modern RAL 840 HR)	-	-	71.020	HTK_225	-	-	-
RC212	Basaltgrau – Basalt Grey	RAL 7012 (Modern RAL 840 HR)	-	-	70.869	HTK_192	79	-	-
RC213	Steingrau – Stone Grey	RAL 7030 (Modern RAL 840 HR)	-	-	-	HTK_233	-	-	-
RC214	Lichtgrau – Light Grey	RAL 7035 (Modern RAL 840 HR)	-	-	-	HTK_191	196	-	-
RC215	Staubgrau – Dusty Grey	RAL 7037 (Modern RAL 840 HR)	-	-	-	HTK_249	-	-	-
RC216	Quarzgrau – Quartz Grey	RAL 7039 (Modern RAL 840 HR)	-	-	-	HTK_248	-	-	-
RC217	Seidengrau – Silk Grey	RAL 7044 (Modern RAL 840 HR)	-	-	-	HTK_173	-	-	-
RC218	Olivbraun – Olive Brown	RAL 8008 (Modern RAL 840 HR)	-	-	71.032	HTK_172	-	-	-
RC219	MNO 2036 Small Khaki Avion	RAL 6013 (Modern RAL 840 HR)	-	-	-	HTK_170	-	-	-
RC220	Light Gull Grey	FS 16440	C315 / H315	-	71.121	HTK_048	129	4692	UA025
RC221	ADC Grey	FS 16473	-	-	71.335	HTK_045	-	1731 / 4693	UA041
RC222	Insignia White	FS 17875	C316 / H316	X-1	71.279	HTK_049	22	1745 / 4696	LC52
RC223	Tan	FS 20400	-	-	71.348	HTK_187	-	2021 / 4697	UA084

Ref.	Name		BS / FS / RAL	Mr. Hobby (GSI)	Tamiya	Vallejo	Hataka	Humbrol	Model Master	Lifecolor
RC224	Brown	☼	FS 30140	-	-	71.035	HTK_160	-	1754	UA085
RC225	Dark Tan	☼☼☼	FS 30219	C310 / H310	-	71.125	HTK_012	118	1742 / 4709	UA015
RC226	Sand	☼☼☼	FS 33531	C313 / H313	XF-59	71.327	HTK_090	121	1706 / 4720	-
RC227	Radome Tan	☼☼☼	FS 33613	C318 / H318	-	71.074	-	148	1709 / 4722	-
RC228	USMC Sand	☼☼☼	FS 33711	-	-	-	HTK_060	-	-	UA090
RC229	US Army Helo Drab	☼☼☼	FS 34031	-	-	-	HTK_067	-	2024 / 4723	-
RC230	Dull Dark Green	☼☼☼	FS 34092	C302 / H302	XF-26	71.124	HTK_056	149	1764 / 4729	UA008
RC231	Field Green	☼☼☼	FS 34097	C340 / H340	-	-	-	-	1712	-
RC232	Pale Green	☼☼☼☼	FS 34227	C312 / H312	-	71.126	HTK_091	120	1716 / 4739	UA060
RC233	Green	☼☼☼☼	FS 34258	-	-	71.094	HTK_093	-	2029	UA115
RC234	Aggressor Blue	☼☼☼☼	FS 35109	-	-	71.111	HTK_156	-	2031	UA404
RC235	Intermediate Blue	☼☼☼☼	FS 35164	C366 / H56	-	71.299	HTK_027	144	1720 / 4744	UA045
RC236	Blue	☼☼☼☼☼	FS 35190	-	-	70.901	-	-	-	-
RC237	Medium Grey	☼☼☼☼☼	FS 35237	C337 / H337	-	71.114	HTK_046	145	1721 / 4746	UA145
RC238	Light Blue	☼☼☼☼☼☼	FS 35414	-	-	71.008	HTK_150	-	2033	UA062
RC239	Air Superiority Blue	☼☼☼☼☼☼	FS 35450	-	-	71.332	HTK_155	47	-	UA037
RC240	Light Sky Blue	☼☼☼☼☼☼	FS 35526	-	-	71.337	-	-	-	UA061
RC241	Duck Egg Blue	☼☼☼☼☼☼☼	FS 35622	C314 / H314	-	71.328	HTK_092	122	1722 / 4748	UA139
RC242	Dark Eggplant Grey	☼☼☼☼☼☼☼	FS 36076	-	-	71.048	HTK_230	-	2034 / 4749	-
RC243	Grey	☼☼☼☼☼☼☼☼	FS 36081	C301 / H301	-	71.314	HTK_030	32	1788 / 4750	UA030
RC244	Medium Gunship Grey	☼☼☼☼☼☼☼☼	FS 36118	C305 / H305	-	71.097	HTK_031	125	1723 / 4752	UA022
RC245	Have Glass Grey	☼☼☼☼☼☼☼☼☼	FS 36170	-	-	-	HTK_058	-	-	-
RC246	F-15 Dark Grey (Mod Eagle)	☼☼☼☼☼☼☼☼☼	FS 36176	-	-	71.273	HTK_158	5	2036 / 4754	UA029
RC247	Dark Gull Grey	☼☼☼☼☼☼☼☼☼	FS 36231	C317 / H317	-	71.277	HTK_044	140	1740 / 4755	UA033
RC248	Aggressor Grey	☼☼☼☼☼☼☼☼☼	FS 36251	-	-	71.274	HTK_157	-	-	UA034
RC249	Medium Grey	☼☼☼☼☼☼☼☼☼	FS 36270	C306 / H306	-	71.275	HTK_054	126	1725 / 4757	UA028
RC250	Light Sea Grey	☼☼☼☼☼☼☼☼☼	FS 36307	C324 / H324	-	-	HTK_266	141	1726 / 4759	UA113
RC251	Dark Ghost Grey	☼☼☼☼☼☼☼☼☼	FS 36320	C307 / H307	-	71.120	HTK_035	128	1741 / 4761	UA027
RC252	Light Ghost Grey	☼☼☼☼☼☼☼☼☼	FS 36375	C308 / H308	-	70.615	HTK_037	127	1728 / 4762	UA026
RC253	Light Grey	☼☼☼☼☼☼☼☼☼	FS 36495	C338 / H338	-	71.276	HTK_050	147	1732 / 4765	UA023
RC254	Camouflage Grey	☼☼☼☼☼☼☼☼☼	FS 36622	C311 / H311	-	71.296	HTK_039	28	4766	UA021
RC255	M-485 Light Grey	☼☼☼☼☼☼☼☼☼	-	-	-	71.298	-	-	-	UA741
RC256	M-485 Blue-Grey	☼☼☼☼☼☼☼☼☼	FS 35189	C367	-	71.109	HTK_218	-	2055 / 4847	UA038
RC257	Sea Blue	☼☼☼☼☼☼☼☼☼	FS 35042	C71 / H55	XF-17	71.295	HTK_006	-	1718	UA044
RC258	Dark Sea Blue	☼☼☼☼☼☼☼☼☼	FS 35045	C365	-	71.300	HTK_001	181	1717 / 4686	UA047
RC259	Dark Olive Drab 41	☼☼☼☼☼☼☼☼☼	FS 33070	C38 / H78	XF-62	71.316	HTK_004	-	-	UA005
RC260	Medium Green 42	☼☼☼☼☼☼☼☼☼	-	-	-	-	HTK_019	-	-	-
RC261	Neutral Grey 43	☼☼☼☼☼☼☼☼☼	-	-	-	71.051	HTK_033	-	-	UA046
RC262	US Interior Yellow Green	☼☼☼☼☼☼☼☼☼	-	-	-	-	-	-	-	-
RC263	Zinc Chromate Yellow	☼☼☼☼☼☼☼☼☼	-	C352	-	71.107	-	-	4851	-
RC264	Bronze Green	☼☼☼☼☼☼☼☼☼	-	-	-	-	-	-	-	-
RC265	RLM 02 RLM-Grau (1938)	☼☼☼☼☼☼☼☼☼	-	C60 / H70	XF-20	71.044	HTK_023	240	2071 / 4770	UA504
RC266	RLM 02 RLM-Grau (1941)	☼☼☼☼☼☼☼☼☼	-	-	-	-	-	-	-	-
RC267	RLM 04	☼☼☼☼☼☼☼☼☼	-	C113 / H413	-	71.078	HTK_066	154	2072 / 4771	UA140
RC268	RLM 61	☼☼☼☼☼☼☼☼☼	-	-	-	71.042	HTK_168	-	2075	-
RC269	RLM 62	☼☼☼☼☼☼☼☼☼	-	-	-	71.104	HTK_169	-	2076	-
RC270	RLM 63	☼☼☼☼☼☼☼☼☼	-	-	-	71.260	HTK_167	-	2077	-
RC271	RLM 65 (1938)	☼☼☼☼☼☼☼☼☼	-	-	-	-	-	65	-	-
RC272	RLM 65 (1941)	☼☼☼☼☼☼☼☼☼	-	C115 / H67	XF-23	71.255	HTK_029	-	2078 / 4778	UA503
RC273	RLM 66 (1941)	☼☼☼☼☼☼☼☼☼	-	-	-	-	-	-	-	-
RC274	RLM 70	☼☼☼☼☼☼☼☼☼	-	C18 / H65	XF-27	71.021	HTK_015	241	2080 / 4780	UA501
RC275	RLM 71	☼☼☼☼☼☼☼☼☼	-	C17 / H64	-	71.015	HTK_017	242	2081 / 4781	UA502
RC276	RLM 72	☼☼☼☼☼☼☼☼☼	-	-	-	71.263	HTK_311	243	2082	-
RC277	RLM 73	☼☼☼☼☼☼☼☼☼	-	-	-	71.256	HTK_312	244	2083	-
RC278	RLM 74	☼☼☼☼☼☼☼☼☼	-	C36 / H68	-	71.258	HTK_313	245	2084 / 4784	UA507
RC279	RLM 75	☼☼☼☼☼☼☼☼☼	-	C37 / H69	-	71.259	HTK_007	246	2085 / 4785	UA508
RC280	RLM 78 (1941)	☼☼☼☼☼☼☼☼☼	-	-	-	-	-	-	-	-
RC281	RLM 78 (1942)	☼☼☼☼☼☼☼☼☼	-	C118 / H418	-	71.101	HTK_314	248	2087	UA512
RC282	RLM 79 (1941)	☼☼☼☼☼☼☼☼☼	-	-	-	-	-	-	-	-
RC283	RLM 79 (1942)	☼☼☼☼☼☼☼☼☼	-	C119 / H66	-	71.278	HTK_014	249	2088 / 4789	UA137
RC284	RLM 80	☼☼☼☼☼☼☼☼☼	-	C120 / H420	-	71.265	HTK_053	-	2089	UA138
RC285	RAF Sky Grey	☼☼☼☼☼☼☼☼☼	FS 26373	-	-	71.339	HTK_302	-	-	UA036
RC286	RAF Dark Green	☼☼☼☼☼☼☼☼☼	BS381C/241	C330 / H330	XF-81	71.324	HTK_143	163	2060 / 4849	UA546
RC287	RAF Dark Earth	☼☼☼☼☼☼☼☼☼	-	C369 / H72	-	71.323	HTK_009	29	2054 / 4846	UA547
RC288	RAF Ocean Grey	☼☼☼☼☼☼☼☼☼	-	C362	XF-82	71.273	HTK_032	106	2057	UA093

Ref.	Name		BS / FS / RAL	Mr. Hobby (GSI)	Tamiya	Vallejo	Hataka	Humbrol	Model Master	Lifecolor
RC289	RAF Medium Sea Grey		BS381C/637	C335 / H335	XF-83	71.307	HTK_034 HTK_141	165	2058	UA094
RC290	RAF Sky		FS 34424	C368	-	71.321	HTK_234	-	2049 / 4840	UA550
RC291	RAF Azure Blue		-	C370	-	71.108	HTK_028	157	2048	UA098
RC292	RAF Middle Stone		-	C21 / H71	-	71.031	HTK_013	225	2052	UA097
RC293	RAF Cockpit Grey-Green		-	C364	XF-71	71.305	HTK_025	78	2062 / 4850	UA551
RC294	RAF Dark Slate Grey		-	-	-	71.309	HTK_202	224	2056	-
RC295	RAF Extra Dark Sea Grey		BS381C/640	C333 / H333	XF-54	71.110	HTK_140	123	-	UA109
RC296	RAF Dark Sea Grey		BS381C/638	C331 / H331	XF-77	71.405	HTK_144	164	2059	-
RC297	RAF PRU Blue		BS381C/636	C72 / H56	XF-18	71.109	HTK_207	230	2061	-
RC298	RAF Light Aircraft Grey		BS381C/627	C332 / H332	-	-	HTK_217	166	-	-
RC299	RAF Camouflage (Barley) Grey		BS381C/626	C334 / H334	XF-80	-	HTK_142	167	-	UA079
RC300	RAF Dark Camouflage Grey		BS381C/629	-	-	-	HTK_214	-	-	-
RC301	RAF Camouflage Beige (Hemp)		BS381C/389	C336 / H336	XF-57	-	HTK_262	168	-	-
RC302	IJN J3 Hai-Iro (Grey)		-	C35 / H61	-	-	-	-	-	-
RC303	IJN J3 SP (Amber Grey)		-	-	-	71.311	-	-	-	-
RC304	IJN D1 Deep Green Black		-	C15 / H59	XF-11	71.325	-	-	-	-
RC305	IJN D2 Green Black		-	-	-	71.322	-	-	-	-
RC306	IJN M3(M) Mitsubishi Interior Green		-	C126	-	-	-	-	-	-
RC307	IJN M3(N) Nakajima Interior Green		-	C127	-	-	-	-	-	-
RC308	AE-9 / All Light Grey		-	-	-	71.414	HTK_127	-	-	-
RC309	All Protective (Green)		-	-	-	71.410	HTK_128	-	-	-
RC310	All Light Blue		-	-	-	71.317	HTK_129	-	-	-
RC311	A-18f Light Blue		-	-	-	71.413	-	-	-	-
RC312	A-19f Green		-	-	-	71.411	-	-	-	-
RC313	AMT-1 Light Brown		-	-	-	71.320	-	-	-	-
RC314	A-21m Light Yellowish Brown		-	-	-	71.415	HTK_074	72	-	UA039
RC315	AMT-4 / A-24m Green		-	-	-	71.301	HTK_073	-	-	-
RC316	AMT-7 Light Blue		-	-	-	71.318	HTK_072	-	-	-
RC317	AMT-11 Blue Grey		-	-	-	71.304	HTK_071	-	-	-
RC318	AMT-12 Dark Grey		-	-	-	71.308	HTK_070	-	-	-
RC319	A-14 Interior Steel Grey		-	-	-	71.336	-	5	-	-
RC320	RLM 76 Version 1		-	-	-	-	-	-	-	-
RC321	RLM 76 Version 2		-	C117 / H417	-	71.257	HTK_038	247	2086 / 4786	UA509
RC322	RLM 76 Late War Variation		-	-	-	71.103	-	-	-	-
RC323	RLM 81 Version 1		-	C121 / H421	XF-51	71.264	HTK_008	251	2090	UA510
RC324	RLM 81 Version 2		-	C123 / H423	XF-74	71.011	HTK_022	253	2091	UA132
RC325	RLM 81 Version 3		-	-	-	-	-	-	-	-
RC326	RLM 82		-	C122 / H422	-	71.022	HTK_020	252	2092	UA511
RC327	RLM 83		-	-	-	-	-	-	-	-
RC328	IJA #1 Hairiyokushoku (Grey Green)		-	C56 / H62	XF-12	71.326	-	-	-	-
RC329	IJA #3 Hairanshoku (Grey Indigo)		-	-	-	-	-	77	-	-
RC330	IJA #7 Ohryoku Nana Go Shoku (Olive Brown)		-	-	-	71.286	-	-	-	-
RC331	IJA #21 Midori Iro (Green)		-	-	-	-	-	-	-	-
RC332	IJA #27 Ao Midori Iro (Blue Green)		-	-	-	-	-	-	-	-
RC333	IJA #29 Ki Midori Iro (Yellow Green)		-	-	-	-	-	-	-	-
RC334	IJA #30 Karekusa Iro (Dry Grass Colour)		-	-	-	-	-	-	-	-
RC335	IJA #31 Cha Kasshoku (Tea Colour)		-	-	-	-	-	-	-	-
RC336	MiG-25/MiG-31 Grey		-	-	-	-	-	-	-	-
RC337	MiG-29 Light Grey		-	-	-	-	-	-	2133	-
RC338	MiG-29 Grey Green		-	-	-	71.340	-	-	2134	-
RC339	RLM 66 (1938)		-	C116 / H416	XF-24	71.055	HTK_040	-	2079 / 4779	UA133
RC340	Kenttävihreä – Olive Green		FS 34096	-	-	-	HTK_301	30	2027	UA142
RC341	Schwarzgrau – Black Grey		RAL 7021 (Modern RAL 840 HR)	-	-	-	HTK_224	-	-	-
RC342	Dark Green		FS 34064	-	-	-	HTK_232	-	-	UA119
RC500	Flat Varnish		-	C182 / H20	XF-86	70.520	HTK-XP07	49	2015 / 4636	LC27
RC501	Satin Varnish		-	C181	-	70.522	HTK-XP08	135	2016 / 4637	LC77
RC502	Gloss Varnish		-	C46 / H30	X-22	70.510	HTK-XP09	35	2017 / 4638	LC73
RC503	Clear Red		-	C47 / H90	X-27	-	-	-	4630	-
RC504	Clear Blue		-	C50 / H93	X-23	-	-	-	4658	-
RC505	Clear Green		-	C138 / H94	X-25	-	-	-	4668	-
RC506	Clear Orange		-	C49 / H92	X-26	-	-	-	4625	-
RC507	Clear Yellow		-	C48 / H91	X-24	-	-	-	-	-
RC508	Clear Smoke		-	C101 / H95	X-19	-	-	-	-	-

5

SPRAYS / AEROSOL

Our sprays allow you to easily and effectively paint both large and small surfaces. This range includes varnishes and a number of primers suitable for coating different materials and available in various colors. The paint inside is a fast drying synthetic lacquer that adheres well to different surfaces and creates an ultra resistant undercoat layer, which holds firmly acrylic and enamel paints or extreme weathering. Remember to shake the spray well before using it!

Nuestros aerosoles le permiten pintar de manera fácil y efectiva superficies grandes y pequeñas. Esta gama incluye barnices y una serie de imprimaciones adecuadas para cubrir e imprimir diferentes materiales. Están disponibles en varios colores. La pintura está compuesta por una laca sintética de secado rápido que se adhiere perfectamente a distintas superficies y crea una capa base ultra-resistente para efectos o envejecimiento extremo. ¡Recuerda agitar bien el spray antes de usarlo!



AK1016
FINE METAL PRIMER
150 ml



AK1017
FINE RESIN PRIMER
150 ml



AK1018
MICROFILLER PRIMER
150 ml



AK1019
GREAT WHITE BASE
150 ml



AK1020
RUST BASECOAT
150 ml



AK1021
FLESH BASE
150 ml



AK1022
ALUMINUM
150 ml



AK1023
DUNKELGELB
150 ml



AK1024
SAND YELLOW
150 ml



AK1025
OLIVE DRAB
150 ml



AK1026
RUSSIAN GREEN
150 ml



AK1027
PANZERGREY
150 ml



AK1009
FINE PRIMER BLACK
400 ml



AK1010
FINE PRIMER GREY
400 ml



AK1011
FINE PRIMER WHITE
400 ml



AK1012
GLOSS VARNISH
400 ml



AK1013
MATT VARNISH
400 ml



AK1014
SEMI-GLOSS VARNISH
400 ml



AK1015
PROTECTIVE VARNISH
400 ml



AK1028
SPRAY DIFFUSERS
SET 1



AK1029
SPRAY DIFFUSERS
SET 2



6

WEATHERING PRODUCTS / PRODUCTOS DE ENVEJECIMIENTO

LABEL EVOLUTION

The legal requirements in the labeling are changing to adapt to the current regulations. The pictograms, their size and the current regulation make the labels change from time to time. The design of the labels also evolves but the quality of the product remains constant. If you have a product with a same reference, it does not matter what label it carries since you have the guarantee that it is a product of the highest quality.

Los requerimientos legales en el etiquetado son cambiantes para adaptarse a la normativa vigente. Los pictogramas, su tamaño y la regulación actual hacen que las etiquetas cambien cada cierto tiempo. El diseño de las etiquetas también evoluciona, pero la calidad del producto permanece constante. Si tienes un producto con una referencia da igual que etiqueta lleve ya que cuentas con la garantía de que es un producto de la más alta calidad.



6.1 FILTERS / FILTROS

Filters are made to bring a subtle difference in tone to a single color, creating a little contrast and adding depth and richness. You can apply a filter straight from the bottle or you can thin it for a more subtle effect with AK011 White Spirit. You can even create light modulation techniques. Filters are unlimited in their use. Available in our familiar 35 ml bottles.

Los filtros están hechos para aportar una sutil diferencia de tono sobre un color, creando un poco de contraste y agregando profundidad y riqueza. Puedes aplicar un filtro directamente de la botella o puedes diluirlo para obtener un efecto más sutil con AK011 White Spirit. Incluso puedes crear técnicas de modulación de luz. Los filtros tienen un uso ilimitado para los modelos a escala. Disponible en nuestras botellas de 35 ml.



AK065
LIGHT BROWN FOR
DESERT YELLOW
(AFRIKA KORPS FILTER)



AK071
BLUE FOR PANZER
GREY



AK076
DARK BROWN FOR
NATO CAMOUFLAGE



AK261
OCHER FOR SAND /
LIGHT FILTER FOR
WOOD



AK262
RED BROWN FILTER
(FILTER FOR WOOD)



AK4161
NEUTRAL GREY FILTER



AK4162
BLUE GREEN FOR
GREEN CAMO

6.2 ENGINE EFFECTS / EFECTOS DE MOTORES

These enamel products allow you to easily recreate the fuel, oil and grease effects that are commonly seen on the engines and other lubricated components of vehicles, aircraft and other machines. Available in our familiar 35 ml bottles.

Estos productos de esmalte permiten recrear fácilmente los efectos de combustible, aceite y grasa que se ven comúnmente en los motores y otros componentes lubricados de vehículos, aviones y otras máquinas. Disponibles en nuestras botellas de 35 ml.



AK025
FUEL STAINS



AK082
ENGINE GRIME



AK084
ENGINE OIL (Fresh
Finish)



AK2019
AIRCRAFT ENGINE OIL



AK2039
KEROSENE LEAKS
AND STAINS



6.3 STREAKING EFFECTS / EFECTOS DE CHORRETONES

The effects of streaking dirt, grime and rust can be seen on vehicles, ships, and aircraft used in different environmental and weather conditions. We offer you various enamel products suitable creating these effects over different base colors. Available in our familiar 35 ml bottles.
 Los efectos del chorretones de suciedad, mugre y óxido se pueden ver en vehículos, barcos y aviones utilizados en diferentes condiciones ambientales y climáticas. Le ofrecemos diversos productos de esmalte adecuados para crear estos efectos dependiendo de los diferentes colores base.



AK012
STREAKING GRIME



AK013
RUST STREAKS



AK014
WINTER STREAKING GRIME



AK024
DARK STREAKING GRIME



AK026
SLIMY GRIME DARK



AK027
SLIMY GRIME LIGHT



AK067
STREAKING GRIME FOR DAK VEHICLES



AK069
STREAKING GRIME FOR PANZER GREY



AK074
RAINMARKS



AK094
STREAKING EFFECTS FOR INTERIOR



AK123
OIF & OEF STREAKING EFFECTS



AK304
STREAKING GRIME FOR RED HULLS



AK305
STREAKING GRIME FOR GREY SHIPS



AK306
SALT STREAKS FOR SHIPS

6.4 DUST, MUD AND NATURE EFFECTS / EFECTOS DE BARRO, POLVO Y NATURALEZA

Enamel products in specially selected colors to easily create natural dust, earth, mud and wet effects. Simply open the jar and apply the product over your model to achieve extreme reality. Available in our familiar 35 ml bottles.

Efectos esmalte especialmente desarrollados para crear fácilmente polvo natural, tierra, barro y efectos húmedos. Simplemente agite, abra el frasco y aplique el producto sobre su modelo para lograr una realidad extrema. Disponible en nuestras botellas de 35 ml.



AK015
DUST EFFECTS



AK016
FRESH MUD



AK017
EARTH EFFECTS



AK022
AFRICA DUST EFFECTS



AK023
DARK MUD



AK078
DAMP EARTH



AK080
SUMMER KURSK EARTH



AK079
WET EFFECTS FLUID



AK2031
LANDING GEAR DUST



6.5 SPECIAL DEPOSITS / DEPÓSITOS ESPECIALES

These enamel weathering products bring a new formula of specialized key ingredients to easily achieve a light surface texture. They are perfect to recreate accumulated dust, rust and dirt on your model. Available in our familiar 35 ml bottles. *Estos productos de esmalte para el envejecimiento tienen una nueva fórmula de ingredientes clave especiales para lograr fácilmente una ligera textura en la superficie. Son perfectos para recrear el polvo, el óxido y la suciedad acumulados en su modelo. Disponible en nuestras botellas de 35 ml.*



6.6 WASHES/LAVADOS

Our extensive range of enamel-based washes is the perfect solution for emphasizing the details of your models in an easy and effective way. Choose a suitable color and apply it straight from the jar to create contrast and depth in the details. *Nuestra amplia gama de lavados con base de esmalte es la solución perfecta para enfatizar los detalles de sus modelos de una manera fácil y efectiva. Elija el color adecuado y aplíquelo directamente del frasco para crear contraste y profundidad en los detalles. Disponible en nuestras botellas de 35 ml.*





6.7 PANELINERS/ PANELADORES

Many modellers struggle as they have to choose a color to accentuate the panel lines of aircraft. We offer you the right color for each scheme, ready for use. This saves you time and effort and you can easily proceed with your model. Available in our familiar 35 ml bottles.

Muchos modelistas tienen dificultad para elegir un color para acentuar las líneas de paneles de los aviones. Le ofrecemos el color correcto para cada esquema, listo para usar. Esto ahorra tiempo y esfuerzo y obtiene los mejores resultados en su modelo. Disponible en botellas de 35 ml.



AK2071
PANELINER FOR BROWN AND GREEN CAMOUFLAGE



AK2072
PANELINER FOR GREY AND BLUE CAMOUFLAGE



AK2073
PANELINER FOR SAND AND DESERT CAMOUFLAGE



AK2074
PANELINER FOR WHITE AND WINTER CAMOUFLAGE



AK2075
PANELINER FOR BLACK CAMOUFLAGE



AK12019
LIGHT GREY PANELINER



AK12020
BLACK PANELINER



AK12021
SEPIA PANELINER



AK12022
DARK BROWN PANELINER



6.8 PIGMENTS/PIGMENTOS

With pigments, we can create different effects, depending on the method of application. Our range offers the most suitable colors for modeling, allowing you to easily choose the right product for the particular task. Available in our familiar 35 ml bottles.

Con pigmentos podemos crear diferentes efectos, dependiendo del método de aplicación (seco, húmedo, mezclado). Nuestra gama ofrece los colores más adecuados para el modelismo, lo que le permite elegir fácilmente el producto adecuado para cada tarea en particular. Disponible en nuestras botellas de 35 ml.



AK039
BLACK PIGMENT



AK040
LIGHT DUST PIGMENT



AK041
NORTH AFRICA DUST PIGMENT



AK042
EUROPEAN EARTH PIGMENT



AK043
MEDIUM RUST PIGMENT



AK044
LIGHT RUST PIGMENT



AK081
DARK EARTH PIGMENT



AK085
TRACK RUST PIGMENT



AK086
DARK STEEL PIGMENT



AK140
SIENNA SOIL PIGMENT



AK141
VIETNAM EARTH PIGMENT



AK142
WHITE ASHES PIGMENT



AK143
BURNT UMBER PIGMENT



AK144
BURNT RUST RED PIGMENT



AK145
CITY DIRT PIGMENT



AK146
ASPHALT ROAD DIRT PIGMENT



AK147
MIDDLE EAST SOIL PIGMENT



AK148
FADED GREEN PIGMENT



AK2038
SMOKE PIGMENT



AK2041
BURNT JET ENGINE PIGMENT



AK2042
DARK RUST PIGMENT



AK2043
OCHER RUST PIGMENT

Pigments can be used dry by applying the powder directly onto the surface, or combined with oils and enamels to achieve other interesting effects.

Los pigmentos se pueden usar secos aplicando el polvo directamente sobre la superficie, o combinados con aceites y esmaltes para lograr otros efectos interesantes.



PIGMENTS: HOW AND WHY / PIGMENTOS: COMO Y PORQUÉ

Pigments are a good product for every modeler. They can be used on their own or in combination with other products. Different colors can be mixed to achieve a greater tonal variety. It's important to avoid a uniform look on your model and pigments can be used to bring life to your model with very convincing results. Pigments can be used over an enamel base in combination with water or with white spirit if a protective varnish was applied. If you use pigments over an acrylic basecoat, you can fix them with white spirit. Once the pigments dry, their original colors will reappear.

Los pigmentos son un buen producto para todos los modelistas. Se pueden usar solos o en combinación con otros efectos. También se pueden mezclar diferentes colores para lograr una mayor variedad cromática. Es importante evitar una apariencia uniforme en su modelo, y los pigmentos logran dar vida a su modelo con resultados muy convincentes. Los pigmentos se pueden usar sobre una base de esmalte en combinación con agua o aguarrás. Si usa pigmentos sobre una capa base acrílica, puede arreglarlos con aguarrás. Una vez que los pigmentos se sequen, sus colores originales volverán a aparecer.



The steel pigment can be used to achieve realistic metallic effects on your model, such as on the edges of metal parts.

El pigmento de acero se puede usar para lograr efectos metálicos realistas, como por ejemplo en los bordes de las partes metálicas.

APPLYING METHODS / MÉTODOS DE APLICACIÓN

1 SINGLE / SOLOS

Pigments can be applied using a soft brush over a matt surface; this will help to retain the pigment. Working this way has as advantage that you can achieve a very subtle finish and create dust effects. The excess pigments can be easily removed. *Los pigmentos se pueden aplicar con un pincel suave sobre una superficie mate; Esto ayudará a retener el pigmento. Trabajar de esta manera tiene la ventaja de que puede lograr un acabado muy sutil y crear efectos de polvo. El exceso de pigmentos se puede eliminar fácilmente.*



2 WHITE SPIRIT

With White Spirit you can apply pigments in all areas with a realistic result. *Con White Spirit puedes aplicar pigmentos en todas las áreas con un resultado realista.*



3 FIXER & TEXTURIZERS / FIJADORES Y TEXTURIZADORES



Texturizer is a high quality acrylic resin developed to be mixed with pigments in order to add textures. It dries out completely matt. Texturizer can be used to create structured mud in terrains or on the desired areas of your model. Small fibers, plaster or real soil can be added to further enhance the effects.

Texturizer es una resina acrílica de alta calidad desarrollada para ser mezclada con pigmentos para agregar texturas. Se seca completamente mate. Texturizer puede usarse para crear barro estructurado en terrenos o en las áreas deseadas de su modelo. Se pueden agregar pequeñas fibras, yeso o tierra real para mejorar aún más los efectos.



Used in combination with plaster we will get a more exaggerated texture perfect for accumulated earth effects, mud or textured soil on your diorama.

Utilizado en combinación con yeso, obtendremos una textura más exagerada perfecta para los efectos de tierra acumulada, barro o suelo con textura en su diorama.

Pigment fixer is developed to fix the pigment in place on any surface. It can be diluted with white spirit and applied before or after the pigments are added to your model. The fixer may darken a little the pigment color.

El fijador de pigmento está desarrollado para fijar el pigmento en cualquier superficie. Se puede diluir con aguarrás y aplicar antes o después de agregar los pigmentos a su modelo. El fijador puede oscurecer un poco el color del pigmento.

Another method of application is using the airflow from your airbrush to blow the mixture on your model, creating splatter effects. *Otro método de aplicación es utilizar el flujo de aire de su aerógrafo para soplar la mezcla en su modelo, creando efectos de salpicadura.*



6.9 WEATHERING SETS/ SETS DE ENVEJECIMIENTO

Our weathering sets combine the most suitable enamel and pigment products for creating the particular effects. Take advantage of our experience and rely on our product selection for best results. Nuestros sets de envejecimiento combinan los productos de esmalte y pigmento más adecuados para crear efectos particulares. Aproveche nuestra experiencia y confíe en nuestra selección de productos para obtener mejores resultados.



AK060
DUST EFFECTS AND WHITE SPIRIT
Included / Incluye: AK011 White Spirit, AK015 Dust Effects, AK022 Africa Dust Effects



AK061
MUD EFFECTS
Included / Incluye: AK016 Fresh Mud, AK017 Earth Effects, AK023 Dark Mud



AK062
STREAKING EFFECTS
Included / Incluye: AK012 Streaking Grime, AK013 Rust Streaks, AK014 Winter Streaking Grime



AK063
SLIMY GRIME AND FUEL WEATHERING SET
Included / Incluye: AK025 Fuel Stains, AK026 Slimy Grime Dark, AK027 Slimy Grime Light



AK064
WEATHERING SET FOR GREEN VEHICLES
Included / Incluye: AK024 Streaking Grime, AK045 Dark Brown Wash, AK046 Light Rust Wash



AK068
AFRICA KORPS WEATHERING SET
Included / Incluye: AK065 Afrika Korps Filter, AK066 Afrika Korps Wash, AK067 Streaking Grime for DAK Vehicles



AK072
PANZER GREY WEATHERING SET
Included / Incluye: AK069 Streaking Grime for Panzer Grey, AK070 Brown Blue Wash, AK071 Blue Filter for Panzer Grey



AK073
NATO WEATHERING SET
Included / Incluye: AK074 Rainmarks, AK075 Wash for NATO Camo Vehicles, AK076 Filter for NATO Tanks



AK077
HEAVY MUDDY WEATHERING SET
Included / Incluye: AK078 Damp Earth, AK079 Wet Effects Fluid, AK080 Summer Kursk Earth, AK081 Dark Earth Pigment, Plaster



AK087
ENGINES AND METAL WEATHERING SET
Included / Incluye: AK082 Engine Grime, AK083 Track Wash, AK084 Engine Oil, AK085 Track Rust Pigment, AK086 Dark Steel Pigment

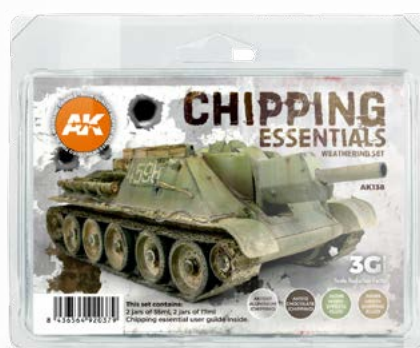

AK138
CHIPPING ESSENTIALS WEATHERING SET
Included / Incluye: AK088 Worn Effects Fluid, AK089 Heavy Chipping Fluid, AK1207 Aluminium (Chipping), AK11113 Chocolate (Chipping)



AK091
INTERIOR WEATHERING SET
Included / Incluye: AK11003 White Grey, AK093 Wash for Interiors, AK094 Streaking Effects for Interior





AK120
OIF & OEF - US VEHICLES
WEATHERING SET

Included / Include: AK121 US Vehicles Wash, AK11349
CARC Tan 606A, AK123 US Streaking Effects



AK2000
AIRCRAFT ENGINE EFFECTS
WEATHERING SET

Included / Include: AK2019 Aircraft Engine Oil, AK2033
Aircraft Engine Wash, AK2039 Kerosene Leaks & Stains



AK2030
AIRCRAFT LANDING
GEAR WEATHERING SET

Included / Include: AK2029 Landing Gear Wash, AK2031
Landing Gear Dust, AK2032 Shafts & Bearings Grease



AK2037
EXHAUST STAINS WEATHERING SET

Included / Include: AK2038 Smoke Pigment, AK2040 Exhaust Wash,
AK2041 Burnt Jet Engine Pigment, AK2042 Dark Rust Pigment, AK2043
Ocher Rust Pigment



AK2070
PANELINERS COMBO SET

Included / Include: AK2071 Brown and Green Camouflage, AK2072 Grey and Blue Camouflage, AK2073 Sand and Desert
Camouflage, AK2074 White and Winter Camouflage, AK2075 Black Camouflage



AK260
WOOD WEATHERING SET

Included / Include: AK261 Light Filter for Wood, AK262
Filter for Brown Wood, AK263 Wash for Wood



AK11651
UNFINISHED GERMAN VEHICLES WEATHERING SET

Included / Include: AK015 Dust Effects, AK093 Wash for Interior, AK11328 RAL 8012 Rotbraun,
AK1112 Medium Rust Deposits

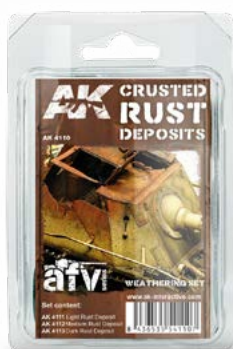

AK4110
CRUSTED RUST DEPOSITS

Included / Include: AK4111 Light Rust Deposit, AK4112
Medium Rust Deposit, AK4113 Dark Rust Deposit



AK4120
BURNT VEHICLES

Included / Include: AK039 Black Pigment, AK048 Pigment Fixer, AK142 White Ashes Pigment, AK143
Burnt Umber Pigment, AK144 Burnt Rust Red Pigment



AK4060
DUST AND DIRT DEPOSITS

Included / Include: AK4061 Sand Yellow Deposit, AK4062 Light Dust
Deposit, AK4063 Brown Earth Deposit



AK4160
MODERN RUSSIAN WEATHERING SET

Included / Incluye: AK042 European Earth Pigment, AK045 Dark Brown Wash, AK11113 Chocolate (Chipping), AK4161 Neutral Grey Filter, AK4162 Blue Green Filter



AK4270
WINTER WEATHERING SET

Included / Incluye: AK014 Winter Streaking Grime, AK088 Worn Effects Fluid, AK751 Washable White, AK8088 Snow Texture



AK688
BASIC WEATHERING SET

Included / Incluye: AK049 Odorless Thinner, AK088 Worn Effects Fluid, AK877 Neutral Grey Wash



AK4089
EARTH EFFECTS (RALLY SET)

Included / Incluye: AK042 European Earth Pigment, AK061 Dark Earth Pigment, AK085 Stirred Earth Splatter Effects

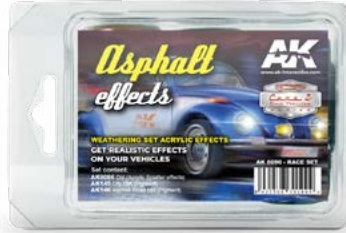

AK4090
ASPHALT EFFECTS (RACE SET)

Included / Incluye: AK145 City Dirt Pigment, AK146 Asphalt Road Dirt Pigment, AK8086 Dirt Splatter Effects



AK4091
SNOW EFFECTS (RALLY SET)

Included / Incluye: AK079 Wet Effects Fluid, AK8087 Wet Ground Splatter Effects, AK8088 Snow Texture



AK4180
DECAY & ABANDONED WEATHERING SET

Included / Incluye: AK148 Faded Green Pigment, AK675 Decay Deposit, AK676 Moss Deposit



AK555
SHIPS WEATHERING SET VOL. 1

Included / Incluye: AK302 Wash for Grey Decks, AK303 Grey Wash for Kriegsmarine Ships, AK304 Brown Streaking Grime for Red Hulls



AK556
SHIPS WEATHERING SET VOL. 2

Included / Incluye: AK301 Dark Wash for Wood Deck, AK305 Streaking Grime for Grey Ships, AK306 Salt Streaks for Ships

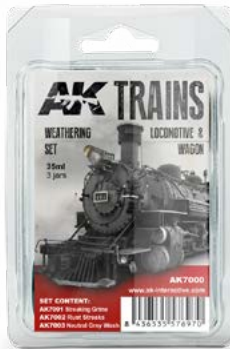

AK7000
TRAINS LOCOMOTIVE & WAGON

Included / Incluye: AK7001 Streaking Grime, AK7002 Rust Streaks, AK7003 Neutral Grey Wash

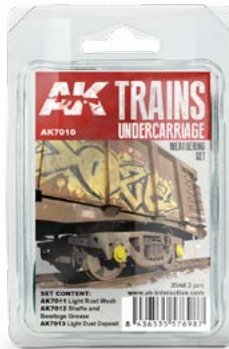

AK7010
TRAINS UNDERCARRIAGE

Included / Incluye: AK7011 Light Rust Wash, AK7012 Shafts and Bearings Grease, AK7013 Light Dust Deposit

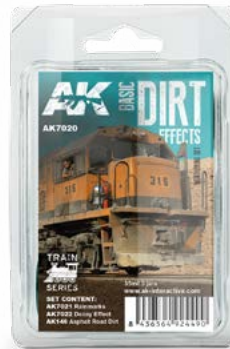

AK7020
BASIC DIRT EFFECTS WEATHERING SET

Included / Incluye: AK146 Asphalt Road Dirt Pigment, AK7021 Rainmarks, AK7022 Decay Effect



AK7023
ROLLING STOCK WEATHERING SET

Included / Incluye: AK086 Dark Steel Pigment, AK2042 Dark Rust Pigment, AK7024 Railroad Wash



W WEATHERING PENCILS FOR MODELLING

THE BEST WEAPON FOR MODELING / EL MEJOR ARMA PARA EL MODELISMO

6.10 WEATHERING PENCILS / LÁPICES PARA EL ENVEJECIMIENTO

Our non-toxic, semi-grease, water-based weathering pencils are available in 37 colors that have been carefully selected for modeling use. They are easy to handle and give you endless possibilities for creating different effects. We recommend to apply them over a matte surface for best results.

Nuestros lápices para el envejecimiento a base de agua, no tóxicos y semi-grasos, están disponibles en 37 colores que han sido cuidadosamente seleccionados para su uso en modelismo. Son fáciles de manejar y le ofrecen infinitas posibilidades para crear diferentes efectos. Recomendamos aplicarlos sobre una superficie mate para obtener mejores resultados.



AK10001 BLACK



AK10002 RUBBER



AK10003 SMOKE



AK10004 WHITE



AK10005 DIRTY WHITE



AK10006 OLIVE GREEN



AK10007 LIGHT GREEN



AK10008 DARK GREEN



AK10009 SAND



AK10010 SEPIA



AK10011 LIGHT RUST



AK10012 MEDIUM RUST



AK10013 DARK RUST



AK10014 STRONG OCHER



AK10015 VIVID ORANGE



AK10016 LIGHT CHIPPING FOR WOOD



AK10017 DARK CHIPPING FOR WOOD



AK10018 GUN METAL (GRAPHITE)



AK10019 CHIPPING COLOR



AK10020 RED PRIMER



AK10021 GREEN BLUE



AK10022 DARK BLUE



AK10023 LIGHT BLUE



AK10024 DARK GREY



AK10025 NEUTRAL GREY



AK10026 DUST / RAINMARKS



AK10027 CONCRETE MARKS



AK10028 EARTH BROWN



AK10029 BUFF



AK10030 STREAKING DIRT



AK10031 RED



AK10032 YELLOW



AK10033 ALUMINUM



AK10034 GOLD



AK10035 DARK ALUMINUM



AK10036 BRONZE



AK10037 COPPER



**AK10039
BLACK & WHITE SHADING &
EFFECTS SET**

Included / Incluye: AK10001 Black, AK10002 Rubber, AK10003 Smoke, AK10004 White, AK10005 Dirty White



**AK10040
GREEN & BROWN SHADING &
EFFECTS SET**

Included / Incluye: AK10006 Olive Green, AK10007 Light Green, AK10008 Dark Green, AK10009 Sand, AK10010 Sepia

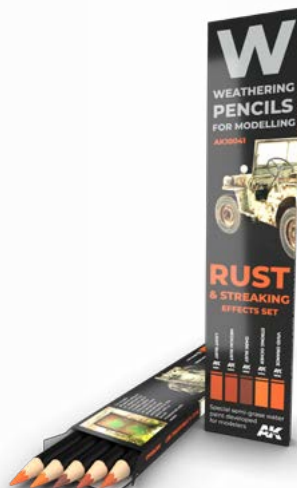

**AK10041
RUST & STREAKING EFFECTS SET**

Included / Incluye: AK10011 Light Rust, AK10012 Medium Rust, AK10013 Dark Rust, AK10014 Strong Ocher, AK10015 Vivid Orange



**AK10042
CHIPPING & AGING SET**

Included / Incluye: AK10016 Light Chipping for Wood, AK10017 Dark Chipping for Wood, AK10018 Gun Metal (Graphite), AK10019 Chipping Color, AK10020 Red Primer



**AK10043
GREY & BLUE SHADING &
EFFECTS SET**

Included / Incluye: AK10021 Green Blue, AK10022 Dark Blue, AK10023 Light Blue, AK10024 Dark Grey, AK10025 Neutral Grey



**AK10044
DIRT & MARKS SET**

Included / Incluye: AK10026 Dust / Rainmarks, AK10027 Concrete Marks, AK10028 Earth Brown, AK10029 Buff, AK10030 Streaking Dirt



**AK10045
BASIC COLORS SHADING &
DEMOTION SET**

Included / Incluye: AK10007 Light Green, AK10023 Light Blue, AK10031 Red, AK10032 Yellow, AK10033 Aluminum



**AK10046
METALLIC EFFECTS SET**

Included / Incluye: AK10033 Aluminum, AK10034 Gold, AK10035 Dark Aluminum, AK10036 Bronze, AK10037 Copper

The weathering pencil sets are composed of five colors. Each set was specially developed to bring the modeller the most suitable colors for a particular task which is the subject of this set. You can find everything from rust and chipping colors, through metallics, to colors suitable for creating shadows and highlights over differently painted surfaces. Proper use of these pencils can take your model to another level.

Los sets de lápices de envejecimiento están compuestos de cinco colores. Cada conjunto se desarrolló especialmente para brindar al modelista los colores más adecuados para una tarea en particular que es el objeto del set. Puede encontrar de todo, desde colores de óxido y desconchones, efectos metálicos, hasta colores adecuados para crear sombras y luces sobre superficies pintadas de manera diferente. El uso adecuado de estos lápices puede llevar a tu modelo a otro nivel.



7

DIORAMA PRODUCTS / PRODUCTOS PARA DIORAMAS



7.1 WATER, SNOW & ICE / AGUA, NIEVE Y HIELO

Water, snow and ice effects are some of the most difficult ones to reproduce. With our range of diorama products you will never again struggle with achieving realistic results, as we have spend a lot of time to bring you the best available solutions. Just give them a try!

Los efectos del agua, la nieve y el hielo son algunos de los más difíciles de reproducir. Con nuestra gama de productos de diorama, nunca más tendrá problemas para lograr resultados realistas, ya que hemos dedicado mucho tiempo a ofrecerte las mejores soluciones disponibles. ¡Solo pruébalos!



AK8043 RESIN WATER BIG 350 ml

A low odor, two component epoxy resin product that simulates crystal clear water. Larger packaging at a more economical price.

Un producto de resina epoxy de dos componentes y bajo olor que simula el agua cristalina. Embalaje más grande a un precio más económico.



AK8044 RESIN WATER MEDIUM 180 ml

A low odor, two component epoxy resin product that simulates crystal clear water.

Un producto de resina epoxy de dos componentes y bajo olor que simula el agua cristalina.



AK8012 RESIN ICE

This two component epoxy resin product allows to create different ice effects. The set also includes an acrylic product to imitate surface textures.

Este producto de resina epoxy de dos componentes permite crear diferentes efectos de hielo. El set también incluye un producto acrílico para imitar texturas de superficie.



AK8008 STILL WATER 250 ml

Still Water is an acrylic liquid product specially designed to reproduce the effect of clear still water.

Still Water es un producto acrílico líquido especialmente diseñado para reproducir el efecto del agua clara tranquila.



AK8002 WATER GEL TRANSPARENT 250 ml

Gel to replicate transparent water. Specially developed to mimic moving and shallow water.

Gel para replicar agua transparente. Especialmente desarrollado para imitar agua en movimiento y aguas poco profundas.



AK8003 WATER GEL ATLANTIC BLUE 250 ml

A dense gel specially developed to mimic the waters of the Atlantic Ocean and other open waters.

Un gel denso especialmente desarrollado para imitar las aguas del Océano Atlántico y otras aguas abiertas.



AK8004 WATER GEL PACIFIC BLUE 250 ml

A dense gel specially developed to mimic the waters of the Pacific Ocean.

Un gel denso especialmente desarrollado para imitar las aguas del Océano Pacífico.



AK8006 WATER GEL SWAMP GREEN 250 ml

A dense brown-green gel specially developed to mimic swamp waters.

Un gel denso de color verde-marrón especialmente desarrollado para imitar las aguas del pantano.



AK8007 WATER GEL EFFECTS 100 ml

The perfect product for recreating any type of moving water effects.

El producto perfecto para recrear cualquier tipo de efectos de agua en movimiento.



AK8009 SNOW SPRINKLES 100 ml

A snow texture product used to create ultra-realistic thin layers of snow.

Un producto de textura de nieve utilizado para crear capas finas de nieve ultra realistas.



AK8010 SNOW MICROBALLOONS 100 ml

Powder snow texture product specially developed to replicate thawing snow or the first phases of a snowfall.

Producto de textura de nieve en polvo especialmente desarrollado para replicar la nieve descongelada o las primeras fases de una nevada.



AK8011 TERRAINS SNOW 250 ml

The perfect product to create a snow texture on any surface - terrain, vehicle or building.

El producto perfecto para crear una textura de nieve en cualquier superficie: terreno, vehículo o edificio.



AK8036 WATER FOAM 100 ml

The perfect product for recreating any white foam in water effects as waves, ripples and waterfalls.

El producto perfecto para recrear cualquier espuma blanca en el agua como olas, ondas y cascadas.



AK8037 ICE SPARKLES 100 ml

A product to use in vehicles, accessories or dioramas to create snow effect as seen during the last phases of a snowfall and thaw.

Un producto para usar en vehículos, accesorios o dioramas para crear un efecto de nieve como se ve durante las últimas fases de una nevada y deshielo.



AK8028 PUDDLES 60 ml

Puddles is a special slightly tinted crystalline acrylic liquid designed to replicate small puddles and standing dirty water.

Charcos es un líquido acrílico cristalino ligeramente teñido especial diseñado para replicar pequeños charcos y agua sucia.

DIORAMA SERIES



PHOTOMONTAGE MODEL SCALE 1:35
THE ORIGINAL BRAND
UNBEATEABLE MODELING PRODUCTS

7.2 TERRAINS / TERRENOS

High quality acrylic products developed to replicate textures in dioramas, vignettes and bases. Offer perfect results when applied both in thin or thick layers. They can be diluted with water or an acrylic thinner to improve their flow. Once dry, you can work with pigments to add tonal variation

Productos acrílicos de alta calidad desarrollados para conseguir texturas en dioramas, viñetas y bases. Ofrece resultados perfectos cuando se aplica en capas finas o gruesas. Se pueden diluir con agua o un diluyente acrílico para mejorar su flujo. Una vez seco, puede trabajar con pigmentos para agregar variación tonal.



AK8013 TERRAINS ASPHALT 250 ml

Scale asphalt texture with a black/grey shade similar to that of roads, highways or any asphalt covered surface.
Textura a escala de asfalto con un tono negro / gris similar al de las carreteras, autopistas o cualquier superficie cubierta de asfalto.



AK8014 TERRAINS CONCRETE 250 ml

Scale concrete texture in a grey shade similar to that of concrete buildings and runways.
Textura a escala de cemento en un tono gris similar al de los edificios y pistas de cemento.



AK8015 TERRAINS DRY GROUND 250 ml

Dry Ground texture is the perfect product and color for recreating any dry soil or arid natural surface.
Esta textura es el producto y el color perfectos para recrear cualquier suelo seco o superficie natural árida.



AK8016 TERRAINS WET GROUND 250 ml

The perfect texture and color for recreating any wet soil or dirt natural surface.
La textura y el color perfectos para recrear cualquier suelo húmedo o superficie natural sucia.



AK8017 TERRAINS MUDDY GROUND 250 ml

Muddy Ground is the perfect texture and color for recreating heavy thick muddy surfaces.
Muddy Ground es la textura y el color perfectos para recrear superficies lodosas gruesas y pesadas.



AK8018 TERRAINS DARK EARTH 250 ml

Dark Earth is the perfect product for recreating rich dark shades of earth bases where a thick and dense texture is desired.
Dark Earth es el producto perfecto para recrear ricos tonos oscuros de bases donde se desea una textura gruesa y densa.



AK8019 TERRAINS BEACH SAND 250 ml

Beach Sand is a fine and flat texture for recreating beach areas.
Beach Sand es una textura fina y plana para recrear áreas de playa.



AK8020 TERRAINS DESERT SAND 250 ml

Desert Sand is a fine and smooth texture suitable for any type of desert scene.
Desert Sand es una textura fina y suave adecuada para cualquier tipo de escena del desierto.



AK8021 TERRAINS LIGHT EARTH 250 ml

Light Earth is the perfect product in texture and tone for recreating lighter shades of earth.
Light Earth es el producto perfecto en textura y tono para recrear tonos más claros de tierra.



AK8022 TERRAINS SANDY DESERT 250 ml

Sandy Desert is perfect for desert terrains; possessing a different color than Desert Sand, Sandy Desert is redder and a thicker textured product.
Sandy Desert es perfecto para terrenos desérticos; Al poseer un color diferente al de Desert Sand, Sandy Desert es más rojo y con una textura más gruesa.



AK8023 TERRAINS NEUTRAL TEXTURE FOR EARTH 250 ml (BASE PRODUCT)

Neutral Earth texture allows the modeler to create their own earth tones, coloring it as desired.
La textura neutra de la Tierra permite al modelista crear sus propios tonos de tierra, coloreándolos como desee.



AK8025 NEUTRAL TEXTURE FOR ROUGH TERRAIN 250 ml (BASE PRODUCT)

Neutral Texture for Rough Terrain is specially designed to reproduce rough and base of rocky terrains.
La textura neutra para terrenos accidentados está especialmente diseñada para reproducir terrenos irregulares y bajos de terrenos rocosos.



7.3 SPLATTER AND CRACKLE EFFECTS /EFECTOS DE SALPICADURAS Y CRAQUELADOS

This range of acrylic products is specially formulated to allow you to easily create various splatter and crackle effects.
Esta gama de productos acrílicos está especialmente formulada para permitirle crear fácilmente diversos efectos de salpicaduras y craquelados.



AK8026 SPLATTER EFFECTS WET MUD 100 ml

Formulated for creating wet mud splatter effects on vehicles, dioramas and vignettes.
Formulado para crear efectos de salpicaduras de lodo húmedo en vehículos, dioramas y viñetas.



AK8027 SPLATTER EFFECTS DRY MUD 100 ml

Formulated for creating dry mud splatter effects on vehicles, dioramas and vignettes.
Formulado para crear efectos de salpicaduras de barro seco en vehículos, dioramas y viñetas.



AK8029 SPLATTER EFFECTS WET GROUND 100 ml

Formulated for creating wet ground splatter and accumulation on vehicles, dioramas and vignettes.
Formulado para crear salpicaduras y acumulación de suelo húmedo en vehículos, dioramas y viñetas.



AK8030 SPLATTER EFFECTS STIRRED EARTH 100 ml

Formulated for creating stirred earth effects on vehicles, dioramas and vignettes.
Formulado para crear efectos de tierra agitada en vehículos, dioramas y viñetas.



AK8031 SPLATTER EFFECTS ACCUMULATED DUST 100 ml

Formulated for creating dust accumulations on vehicles, dioramas and vignettes.
Formulado para crear acumulaciones de polvo en vehículos, dioramas y viñetas.



AK8032 DARK & DRY CRACKLE EFFECTS 100 ml

Formulated for creating dark, dry and cracked soil on vehicles, dioramas and vignettes.
Formulado para crear suelos oscuros, secos y agrietados en vehículos, dioramas y viñetas.



AK8033 LIGHT & DRY CRACKLE EFFECTS 100 ml

Formulated for creating light, dry and cracked soil on vehicles, dioramas and vignettes.
Formulado para crear suelo ligero, seco y agrietado en vehículos, dioramas y viñetas.



AK8034 WET CRACKLE EFFECTS 100 ml

Formulated for creating wet crackled soil on vehicles, dioramas and vignettes.
Formulado para crear tierra húmeda y craquelada en vehículos, dioramas y viñetas.



AK8035 SPLATTER EFFECTS DIRT 100 ml

Formulated for creating dirty splatter effects and textures on vehicles, dioramas and vignettes.
Formulado para crear efectos sucios de salpicaduras y texturas en vehículos, dioramas y viñetas.



AK8039 FOAM TEXTURIZER & SEALER – FOR BUILDINGS AND DIORAMAS 250ml

Foam Sealer is a fine paste intended for sealing any type of foam. This paste does not damage the foam and protects it from subsequent aggressive processes. It is an acrylic product, so you can dilute it with water and clean your tools easily. We recommend to apply it with a spatula to distribute the paste over the foam. Dries in one hour (depending on the thickness of the applied layer and the environmental conditions). Comes in a neutral white color not to affect the further paint layers. Close the packaging well, allowing the product to last longer. Use a spatula or an old brush for handling.
Foam Texturizer & Sealer es una pasta fina diseñada para sellar cualquier tipo de espuma. Esta pasta no daña la espuma y la protege de los procesos agresivos posteriores. Es un producto acrílico, por lo que puede diluirlo con agua y limpiar sus herramientas fácilmente. Recomendamos aplicarlo con una espátula para distribuir la pasta sobre la espuma. Se seca en una hora (dependiendo del grosor de la capa aplicada y las condiciones ambientales). Viene en un color blanco neutro para no afectar las capas de pintura adicionales. Cierre bien el bote, permitiendo que el producto dure más. Use una espátula o un pincel viejo para manipular.



7.4 SPECIALS / ESPECIALES

The Moss and Corrosion Texture products help to add more realism to your vignettes and dioramas, whilst the Leaves and Plants Neutral Protection liquid allows for the preservation of the pieces of natural vegetation which are often used by modelers to replicate the plants in scale.

Los productos de textura de musgo y corrosión ayudan a agregar más realismo a sus viñetas y dioramas, mientras que el líquido de protección neutral de hojas y plantas permite la preservación de las partes de vegetación natural que a menudo usan los modelistas para reproducir las plantas a escala.



AK8038
MOSS TEXTURE 100 ml

This colored grained foam is ideal for applying moss like seen in forest and moist areas.

Esta espuma granulada coloreada es ideal para aplicar musgo como se ve en bosques y áreas húmedas.



AK8040
CORROSION TEXTURE 100 ml

Formulated for creating surface textures such as corrosion on vehicles, or any element of your dioramas and vignettes.

Formulado para crear texturas superficiales de corrosión en vehículos o cualquier elemento de sus dioramas y viñetas.



AK8042
NATURAL LEAVES & PLANTS
NEUTRAL PROTECTION 250 ml

Reusable preservative for natural plants.
Conservante reutilizable para plantas naturales.

7.5 BUILDING MATERIALS / MATERIALES DE CONSTRUCCIÓN

There's no need to look for building materials in any weird places - we have selected the best materials for modeling purposes specially for you. They are available in different sizes and at competitive prices.

No hay necesidad de buscar materiales de construcción en lugares extraños: hemos seleccionado los mejores materiales para fines de modelado especialmente para usted. Están disponibles en diferentes tamaños y espesores.

7.5.1 CORK / CORCHO



AK8046
CORK SHEET - FINE GRAINED
200X300X1 mm



AK8047
CORK SHEET - FINE GRAINED
200X300X2 mm



AK8048
CORK SHEET - FINE GRAINED
200X300X3 mm



AK8049
CORK SHEET - FINE GRAINED
200X300X1-2-3 mm



AK8052
CORK SHEET - FINE GRAINED
200X290X6 mm



AK8053
CORK SHEET - COARSE GRAINED
200X300X2 mm



AK8054
CORK SHEET - COARSE GRAINED
200X300X3 mm



AK8055
CORK SHEET - COARSE
GRAINED 200X290X6 mm

7.5.2 CARVING FOAM / ESPUMA PARA TALLAR



AK8092
CARVING FOAM 10 mm
A5 SIZE



AK8093
CARVING FOAM 8 mm
A5 SIZE



AK8094
CARVING FOAM 10 mm
A4 SIZE



AK8095
CARVING FOAM 8 mm
A4 SIZE

7.5.3 CONSTRUCTION FOAM / ESPUMA PARA CONSTRUIR

This blue styrofoam can be used for creating various structural elements of a vignette or diorama, such as walls, building, ruins, cobblestone and other types of pavements, etc.

- Can be cut to required shape with the help of a cutter.
 - Can be glued with PVA adhesive.
 - You can carve the surface with the help of the AK9005 Tools Set to simulate bricks, stones, or wood. The surface can also be shaped using a stamping roller.
 - The surface can be sanded.
 - We recommend to prime the surface with an acrylic primer to enhance adhesion of the further coats of paint and weathering products.
 - This material is cut with a hot wire. The surface can show dents and shape irregularities, which can be smoothed by sanding.
- Este poliestireno está indicado para la construcción y talla de elementos dentro de una viñeta o un diorama, una pared, un edificio, una ruina, una valla, un empedrado, etc...*
- Se puede cortar a la forma requerida con la ayuda de un cutter.
 - Se puede pegar con adhesivo PVA (cola blanca).
 - Puede tallar la superficie con la ayuda del juego de herramientas AK9005 para simular ladrillos, piedras o madera. La superficie también se puede conformar con un rodillo de estampado.
 - La superficie se puede lijar.
 - Recomendamos imprimir la superficie con una imprimación acrílica para mejorar la adhesión de otras capas de pintura y productos de weathering.
 - Este material está cortado con un alambre caliente industrial. La superficie puede mostrar abolladuras e irregularidades en la forma, que pueden alisarse lijando.



AK8096
CONSTRUCTION FOAM 6MM
BLUE FOAM HIGH DENSITY
195X295MM INCLUDES 2 SHEETS



AK8097
CONSTRUCTION FOAM 10MM
BLUE FOAM HIGH DENSITY
195X295MM INCLUDES 2 SHEETS



AK8098
CONSTRUCTION FOAM 6 & 10MM
BLUE FOAM HIGH DENSITY
195X295MM INCLUDES 2 SHEETS

7.5.4 EXTRUDED FOAM / ESPUMA EXTRUIDA

Extruded foam is the best material for the base of your diorama or vignette. Its surface and overall shape can be easily adapted to your requirements, although it is not really suitable for carving. Now you don't have to buy and store extra-large pieces, as we bring you this foam in reasonably- sized pieces that will suit most modelers' needs.

El poliuretano extruido es el mejor foam para las bases de tu diorama o viñeta. Su superficie y forma general se pueden adaptar fácilmente a tus necesidades. No es apto para la talla. Ya no tienes que comprar y almacenar piezas extra grandes, ya que te traemos esta espuma en piezas de tamaño razonable que se adaptarán a las necesidades de la mayoría de los modelistas.



AK8099
EXTRUDED FOAM 30MM
SIZE A4





AK8100
EXTRUDED FOAM 30MM
SIZE A4 ALREADY CUT (4 UNITS)

7.6 VEGETATION / VEGETACIÓN

Our CO2 laser-cut leaves are the most detailed leaves available on the market, and are offered in several variants to meet every modeller's needs. Their use brings a distinctive and ultra-realistic touch to your dioramas and vehicles. They can be easily fixed in place with tiny quantities of white glue, diluted white glue, or AK118 Gravel & Sand Fixer.

Nuestras hojas cortadas con láser de CO2 son las hojas más detalladas disponibles en el mercado y se ofrecen distintas variantes para satisfacer las necesidades de cada modelista. Su uso brinda un toque distintivo y ultra realista a sus dioramas y vehículos. Se pueden fijar fácilmente en su lugar con pequeñas cantidades de cola blanca, cola blanca diluida o AK118 Gravel & Sand Fixer.

7.6.1 REALISTIC LEAVES / HOJAS REALISTAS

					
AK8045 DRIED SEA GRASS	AK8101 LIME DRY LEAVES	AK8102 BIRCH AUTUMN	AK8103 MAPLE AUTUMN	AK8104 MAPLE DEAD	AK8105 OAK AUTUMN
					
AK8106 NORTHERN RED OAK AUTUMN	AK8107 OAK DRY	AK8108 OAK DEAD LEAVES	AK8109 UNIVERSAL DRY LEAVES	AK8110 TROPICAL LEAVES	AK8113 MAPLE RED
					
AK8114 ALAMO POPLAR WINTER	AK8115 HOLM OAK AUTUMN	AK8152 MAPLE SUMMER 28mm / 1.72 - BAG 7gr.	AK8153 MAPLE AUTUMN 28mm / 1.72 - BAG 7gr.	AK8154 BIRCH AUTUMN 28mm / 1.72 - BAG 7gr.	
					
AK8155 BIRCH LIGHT GREEN 28mm / 1.72 - BAG 7gr.	AK8156 BIRCH DARK GREEN 28mm / 1.72 - BAG 7gr.	AK8157 OAK SUMMER 28mm / 1.72 - BAG 7gr.	AK8158 OAK AUTUMN 28mm / 1.72 - BAG 7gr.	AK8159 OAK LATE AUTUMN 1.35 BAG 7gr.	



DIORAMA SERIES

F.A.Q. DIORAMAS



BY RUBÉN GONZÁLEZ

BY MARIJN VAN GILS

BY RUBÉN GONZÁLEZ



DIORAMA PRODUCT RANGE

WWW.AK-INTERACTIVE.COM



AKINTERACTIVE / 75



AK8162
OAK AUTUMN 1.35
BAG 7gr.



AK8163
OAK SUMMER 1.35
BAG 7gr.



AK8164
MAPLE AUTUMN 1.35
BAG 7gr.



AK8165
MAPLE SUMMER 1.35
BAG 7gr.

7.6.2 TUFTS / ARBUSTOS

These new miniature vegetation products are perfect to complement your scenes, figure bases and any type of diorama in which you need an extra touch of realism. They are self-adhesive and therefore very easy to use: simply remove the tufts of grass using a pair of tweezers, and place them on the surface. We recommend to fix them with tiny quantities of white glue or AK118 Gravel & Sand Fixer to additionally strengthen the junction.

Estos nuevos productos de vegetación en miniatura son perfectos para complementar tus escenas, bases de figuras y cualquier tipo de diorama en el que necesites un toque extra de realismo. Son autoadhesivos y, por lo tanto, muy fáciles de usar: simplemente quite los mechones de hierba con unas pinzas y colóquelos en la superficie. Le recomendamos que los lije con pequeñas cantidades de cola blanca o AK118 Gravel & Sand Fixer para reforzar adicionalmente la unión.



AK8116
AUTUMN TUFTS 6 mm



AK8117
DRY TUFTS 6 mm



AK8118
LIGHT GREEN TUFTS
6 mm



AK8119
MIXED GREEN TUFTS
6 mm



AK8120
SUMMER GREEN TUFTS
6 mm



AK8121
WINTER TUFTS 5 mm



AK8122
BACKWATER TUFT 4 mm



AK8123
WILD TUFTS 5 mm



AK8124
SUMMER GREEN TUFTS
2 mm



AK8125
STEPPE TUFTS 12 mm



AK8126
DRY TUFTS 12 mm



AK8127
LIGHT GREEN TUFTS
12 mm



AK8128
BACKWATER TUFTS
8 mm



AK8129
DENSE AUTUMN TUFTS
8 mm



AK8130
DENSE SPRING TUFTS
8 mm



AK8131
REALISTIC DARK GREEN
MOSS



AK8132
REALISTIC GREEN MOSS



AK8139
DIO-MAT TUFTS WITH
FALLEN LEAVES SUMMER



AK8140
DIO-MAT TUFTS WITH FALLEN
LEAVES AUTUMN



AK8141
BEECH FOLIAGE FALL



AK8142
BIRCH FOLIAGE FALL



AK8143
BLOSSOM TUFTS FALL



AK8144
LEAVES AND SHRUBBERY FOLIAGE
(ELONGATED)



AK8145
BEECH FOLIAGE SUMMER



AK8146
PLATANE FOLIAGE SUMMER



7.6.3 SHRUBBERY / MATORRALES

These medium-sized synthetic shrubs and shrubs with a woody trunk can be used for variety and scrub density on any terrain. The packaging is designed to keep its shape completely random. The reproduction of the slim trunk is used to facilitate its arrangement in any setting.

Place in the desired place with a pair of tweezers. They can be cut to vary its height with scissors. They can be glued with PVA glue. Possibility of combining different colors to achieve greater dynamism and color variety. Combining different heights and densities allows for achieving really convincing results.

Estos arbustos sintéticos de tamaño mediano y arbustos con un tronco leñoso se pueden utilizar para obtener variedad y lograr densidad de matorral en cualquier terreno. El embalaje está diseñado para mantener su forma completamente aleatoria. La reproducción del tronco delgado se usa para facilitar su disposición en cualquier escenario. Colocar en el lugar deseado con un par de pinzas. Se puede cortar para variar su altura con unas tijeras. Se pueden pegar con cola PVA. Posibilidad de combinar diferentes colores para lograr un mayor dinamismo y variedad cromática. Combinando diferentes alturas y densidades lograremos realmente sorprendentes resultados.



30mm-40mm

AK8166
SUMMER GREEN SHRUBBERIES
1:35 / 75MM / 90MM



30mm-40mm

AK8167
SPRING GREEN SHRUBBERIES
1:35 / 75MM / 90MM



30mm-40mm

AK8168
SUMMER DARK GREEN SHRUBBERIES
1:35 / 75MM / 90MM



30mm-40mm

AK8169
AUTUMN YELLOW SHRUBBERIES
1:35 / 75MM / 90MM



30mm-40mm

AK8170
AUTUMN BROWN SHRUBBERIES
1:35 / 75MM / 90MM



30mm-40mm

AK8171
SPRING LIGHT GREEN SHRUBBERIES
1:35 / 75MM / 90MM



30mm-40mm

AK8172
LATE SUMMER GREEN SHRUBBERIES
1:35 / 75MM / 90MM



30mm-40mm

AK8173
BLOMMING PINK SHRUBBERIES
1:35 / 75MM / 90MM



30mm-40mm

AK8174
BLOMMING WHITE SHRUBBERIES
1:35 / 75MM / 90MM



30mm-40mm

AK8175
BLOMMING YELLOW SHRUBBERIES
1:35 / 75MM / 90MM

7.6.4 LASER-CUT REALISTIC PLANTS / PLANTAS REALISTAS CORTADAS CON LÁSER



AK8134
FERN



AK8135
DRY FERN



AK8136
BRACKEN
FERN



AK8137
IVY



AK8138
JUNGLE PLANTS SET



DIORAMA SERIES

CREATE YOUR OWN FOREST

ALL YOU NEED WITH AK VEGETATION

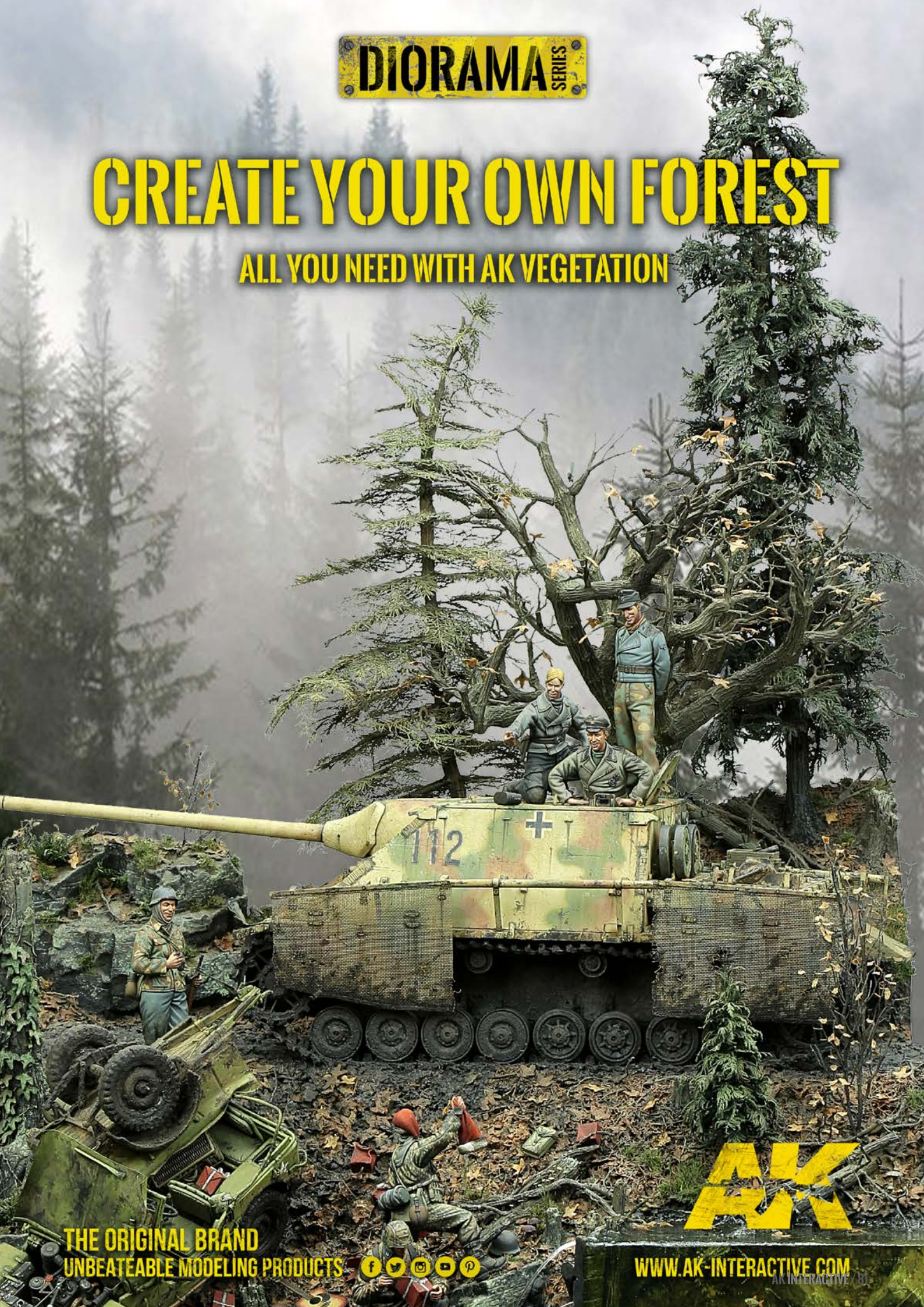

THE ORIGINAL BRAND
UNBEATEABLE MODELING PRODUCTS



AK
AK

WWW.AK-INTERACTIVE.COM

AK INTERACTIVE / BI

8

AUXILIARY PRODUCTS / PRODUCTOS AUXILIARES

To make your life easier, we have developed numerous products that complement our paint and weathering product ranges. From high quality thinners and varnishes, to fixers, putties, tools and other special items, AK Interactive brings you everything you need to take your models to the next level.
 Para facilitarle la vida, hemos desarrollado numerosos productos que complementan nuestra gama de productos de pintura y envejecimiento. Desde diluyentes y barnices de alta calidad hasta fijadores, masillas, herramientas y otros artículos especiales, AK Interactive le ofrece todo lo que necesita para llevar sus modelos al límite.

8.1 THINNERS & CLEANERS / DISOLVENTES Y LIMPIADORES



AK011
WHITE SPIRIT
35 ml



AK047
WHITE SPIRIT
100 ml

Our white spirit is perfect for diluting and blending enamel and oil based products. It is also available in an economical 100 ml bottle.

Nuestro White Spirit es perfecto para mezclar y diluir productos a base de esmalte y aceite. También disponible en una botella mas económica de 100 ml.



AK049
ODORLESS THINNER
35 ml



AK050
ODORLESS THINNER
100 ml

Our odorless thinner is very different from our white spirit. Besides being odorless, this product is softer and less aggressive than white spirit. This property of the odorless thinner (turpentine) makes it a perfect choice for delicate, soft and subtle blending the enamel and oil colors.

Nuestro Thinner sin olor es muy diferente de nuestro White Spirit. Además de ser inodoro, este producto es más suave y menos agresivo que nuestro White Spirit. Esta propiedad del diluyente sin olor (Trementina) lo hace ideal para mezclas delicadas, suaves y sutiles. Este diluyente es exclusivo para esmalte y pintura al óleo.



AK268
NITRO THINNER 100 ml

Thanks to its strong formula, developed at AK Interactive factory, our Nitro Thinner can be used both to dilute paints and clean your brushes and any other painting tools.

Gracias a su fórmula fuerte, desarrollada en la fábrica AK-Interactive, nuestro nuevo Nitro Thinner se puede usar tanto para diluir como para limpiar sus pinceles y cualquier otra herramienta de pintura.



AK470
XTREME CLEANER & THINNER 100 ml

High quality airbrush cleaner and thinner for our Xtreme Metal range. It can be used for diluting all of our metallic colors, as well as for other purposes, such as cleaning tools and diluting putty or other brand's paints that have the same base components.

Limpiador y diluyente para aerógrafo de alta calidad para nuestra gama Xtreme Metal. Se puede utilizar para toda nuestra gama de colores metálicos, así como para otros fines, como limpieza de herramientas, diluir masilla u otras marcas de pinturas que tienen los mismos componentes básicos. Funciona tanto como limpiador como para diluir las pinturas si es necesario.



AK11500
3G THINNER
100 ml



AK712
ACRYLIC THINNER
60 ml

Water-based, non-toxic, low odor thinner specially designed for use with AK Interactive acrylic paints. It also works well with any other water-based acrylic paints from other brands. Our specially formulated product is ideal for creating the perfect paint consistency for both brush and airbrush applications.

Diluyente acrílico especialmente diseñado para usar con acrílicos AK-Interactive. Nuestro diluyente no tóxico de bajo olor también es compatible para su uso con otras marcas.

No es el típico diluyente a base de agua y alcohol, nuestro producto especialmente formulado es ideal para crear la perfecta consistencia de pintura para pincel y aerógrafo.



AK119
PERFECT CLEANER
100 ml



AK11505
3G PERFECT CLEANER
250 ml

Cleaning solution designed for removing acrylics from brushes and airbrushes. It can also function as a lubricant when you want to leave and rest your airbrush for a couple of hours and want to keep the needle clean.

Solución de limpieza diseñada para eliminar los acrílicos de los pinceles y aerógrafos. También puede funcionar como lubricante cuando desea dejar descansar su aerógrafo durante un par de horas y mantener limpia la aguja.



AK701
REAL COLORS THINNER
200 ml



AK702
REAL COLORS THINNER
400 ml

Very high quality, non-toxic and odorless thinner specially designed for AK Interactive Real Colors. Due its high compatibility it is also excellent for thinning lacquer-based paints from other brands. Our specially formulated product is ideal for creating the perfect paint consistency for smooth airbrush application.

Diluyente de muy alta calidad. Especialmente diseñado para usar con AK Interactive Real Colors. Debido a su alta compatibilidad también es Compatible para usar con otras marcas.

No es solo el típico diluyente, nuestro producto especialmente formulado es ideal para crear la perfecta consistencia de pintura para el pincel y para preparar sus pinturas para usar con aerógrafo.

8.2 VARNISHES/BARNICES

3GEN RANGE GAMA 3ª GENERACIÓN



AK11237
MATT VARNISH
100 ml



AK11238
SATIN VARNISH
100 ml



AK11239
GLOSS VARNISH
100 ml

The new range of varnishes within the 3rd generation acrylics line is designed to be applied over any type of paint with a smooth and even finish, providing maximum protection and a matt, satin or gloss finish.

La nueva gama de barnices de esta línea están pensados para ser aplicados sobre cualquier tipo de pintura con un acabado suave y liso, aportando máxima protección y un acabado mate, satinado o brillante.

BASIC LINE GAMA BÁSICA



AK183
ULTRA MATTE VARNISH
60 ml

A high quality ultra matte varnish which can be applied with a brush or an airbrush to achieve a dead flat finish on any surface.

Un barniz ultra mate de alta calidad que se puede aplicar con un pincel o un aerógrafo para lograr un acabado mate en cualquier superficie.



AK190
MATTE VARNISH
60 ml

Acrylic matte varnish formulated for the best airbrush performance. Water soluble, odorless and non-toxic. Shake before each use. We recommend AK712 Acrylic Thinner for thinning. Dries completely in 12 hours. Barniz acrílico mate formulado para el máximo rendimiento del aerógrafo. Soluble en agua, sin olor, y no tóxico. Agitar antes de cada uso. Recomendamos el diluyente acrílico AK712 para diluir. Se seca completamente en 12 horas.



AK191
SATIN VARNISH
60 ml

Acrylic satin varnish formulated for the best airbrush performance. Water soluble, odorless and non-toxic. Shake before each use. We recommend AK712 Acrylic Thinner for thinning. Dries completely in 12 hours. Barniz acrílico satinado formulado para el máximo rendimiento del aerógrafo. Soluble en agua, sin olor, y no tóxico. Agitar antes de cada uso. Recomendamos el diluyente acrílico AK712 para diluir. Se seca completamente en 12 horas.



AK192
GLOSSY VARNISH
60 ml

Acrylic gloss varnish formulated for the best airbrush performance. Water soluble, odorless and non-toxic. Shake before each use. We recommend AK712 Acrylic Thinner for thinning. Dries completely in 12 hours. Barniz acrílico brillante formulado para el máximo rendimiento del aerógrafo. Soluble en agua, sin olor, y no tóxico. Agitar antes de cada uso. Recomendamos el diluyente acrílico AK712 para diluir. Se seca completamente en 12 horas.



AK9040
ULTRA GLOSS VARNISH

Two-component ultra gloss lacquer. The box contains 60 ml of thinner, 60 ml of lacquer and 20 ml of hardening agent, plus two syringes. Mix the lacquer and hardener in a 3:1 ratio, apply the mixture over your models and get the maximum shine.

Laca ultra brillo de dos componentes. La caja contiene 60 ml de diluyente, 60 ml de laca y 20 ml de agente de endurecimiento, más dos jeringas. Mezcle la laca y el endurecedor en una proporción de 3:1, aplique la mezcla sobre sus modelos y obtenga el máximo brillo.



WHAT ARE THEY / QUE SON

Varnish is a dilution of one or more resinous substances in a liquid thinner. The air volatilizes this liquid, which dries due to evaporation, leaving a film over the surface where it has been applied. Many kinds of varnishes exist depending on the thinner or resin used for their fabrication. AK Interactive, in its line of acrylic paints, has different types of vinyl-based varnish in its lines Standard and 3Gen which offer us the following finishes: ultra-matt (AK183), matt (AK190/AK775/AK11237), satin (AK191/AK776/AK11238) and glossy (AK192/AK777/AK11239). All of them are the best quality.

El barniz es una dilución de una o más sustancias resinosas en un diluyente líquido. El aire volatiliza este líquido, que se seca debido a la evaporación, dejando una película sobre la superficie donde se ha aplicado.

Existen muchos tipos de barnices según el diluyente o la resina utilizada para su fabricación. Actualmente, AK Interactive en su línea de pinturas acrílicas tiene distintos tipos de barnices con una base acrílica y distintas resinas en las líneas Standard y 3Gen que nos ofrece los siguientes acabados: ultra mate (AK183), mate (AK190/AK775/AK11237), satinado (AK191/AK776/AK11238) y brillante (AK192/AK777/AK11239). Todos ellos son de la mejor calidad.

WHY USE THEM / PORQUE USARLOS

Their main task is to protect and preserve the surface where they are applied, from the effect of atmospheric agents, such as dust, as well as to provide the surface with better resistance for any subsequent painting processes which can be very aggressive in nature.

Su tarea principal es proteger y preservar la superficie donde se aplican del efecto de los agentes atmosféricos, como el polvo, así como proporcionar a la superficie una mejor resistencia para los procesos de pintura posteriores, que pueden ser de naturaleza muy agresiva.

HOW TO USE THEM / CÓMO USARLOS

To obtain a smooth and uniform finish, it is recommended that you apply the varnish with an airbrush and to prepare the surface properly; that is, free of dust and grease. In order to have a clean atmosphere, we can spray some water into the air so the water will capture all the dust particles and drop them. When airbrushed properly, we actually guarantee a continuous layer, without imperfections, and with an adequate and uniform thickness.

Even though the special formula of the ultra matt varnish allows this varnish to be applied with a brush, thus obtaining a good result, we can also use a brush to apply other products and varnish small details.

The varnishes can be applied directly from the jar or slightly diluted with AK712/AK11500 Thinner. To obtain the best results, it is better to apply several layers instead of trying to apply just one heavy coat, as this may put your model at risk of surface ruination.

Para obtener un acabado suave y uniforme, es conveniente aplicar los barnices con un aerógrafo y preparar la superficie correctamente; Es decir, libre de polvo y grasa. Para tener una atmósfera limpia, podemos rociar un poco de agua en el aire para que el agua capture todas las partículas de polvo y las deje caer. Cuando lo aplicamos con aerógrafo, garantizamos una capa continua, sin imperfecciones, con un grosor adecuado y uniforme.

A pesar de que la fórmula especial del barniz ultra mate permite que este barniz se aplique con un pincel, obteniendo así un buen resultado, también podemos usar un pincel para aplicar los otros productos y barnizar pequeños detalles.

Los barnices pueden aplicarse directamente desde el bote o diluirse ligeramente con el diluyente AK712. Para obtener los mejores resultados, es mejor aplicar varias capas en lugar de tratar de aplicar solo una capa gruesa, ya que puede poner a nuestro modelo en riesgo de arruinar la superficie y el resultado deseado.



3GEN RANGE GAMA 3 GENERACIÓN



BASIC LINE GAMA BÁSICA



WHEN TO USE THEM / CUANDO USARLOS

If we follow the painting and finishing process on any model, there will be different stages where it is recommended that you apply varnish. The first of these stages happens after the use of the base layer and just before applying the decals. For these decals to be fixed properly and not to be seen or felt, we should varnish the surface with the glossiest finish possible.

After this process, it is recommended that you varnish over the decals again to create a film that will protect and definitively fix them. This will prevent them from suffering any damage during any handling of the model. In this case, the choice of the varnish will depend on the model. If it is a civil model, we should use a satin or gloss varnish. Whereas, if it is a military model, we will use satin or matt varnish.

It is advisable to use varnish after the chipping process using the AK088 and AK089 chipping fluids. Once we have finished all the work, and before moving into the weathering process, it is important to coat the model with one or two layers of varnish. The kind of varnish will depend on the model. After the previous process, if we choose to apply oils directly to highlight the base color, we must let it dry thoroughly after being diffused. To protect this from any subsequent enamel-based weathering product, we need to seal the work with a layer of varnish.



The use of varnishes before the washing process is also necessary. In this case, regardless of the model, it is good practice to apply a gloss or satin finish for the wash to run correctly. On the other hand, when we apply a filter, it is recommended that you do it on a matt surface, so it spreads with ease.

From this point, it is the different weathering processes themselves and the mediums (oils, enamels, pigments, acrylics...) and the way we use them (filters, washes, weathering, dusting...) over our model, which will create different finishes on the various areas of the model. This richness is something we want, so we should never, under any circumstances, use a general varnish layer, which will unify the result, thus losing all its visual richness.

Si seguimos el proceso de pintura y acabado en cualquier modelo, habrá diferentes momentos en los que es recomendable barnizarlo.

El primero de estos momentos ocurre después del uso de la capa base y justo antes de aplicar las calcas. Para que estas calcas se fijen correctamente y no se vean ni se sientan, debemos barnizar la superficie con el acabado más brillante posible.

Después de este proceso, es conveniente volver a barnizar las calcas para crear una película que las proteja y las arregle definitivamente, lo que evitará que sufran daños durante el manejo posterior del modelo. En este caso, la elección del barniz, dependerá del modelo.

Si es un modelo civil, deberíamos usar un barniz satinado o brillante. Considerando que, si se trata de un modelo militar utilizaremos barniz satinado o mate.

Es recomendable utilizar barniz después del proceso de desconchar utilizando las referencias AK088 y AK089. Una vez que hayamos terminado todo el trabajo, una vez que hayamos terminado todo el trabajo y antes de pasar al proceso de envejecimiento, es importante cubrir el modelo con una o dos capas de barniz. El tipo de barniz dependerá del modelo.

Después del proceso anterior, si elegimos aplicar óleos para resaltar la base, aplicar los óleos directamente sobre la superficie y difundirlos más adelante cuando terminemos este proceso y cuando el óleo esté seco, se recomienda aplicar una capa de barniz. Sellar el trabajo para que no se vea afectado por los esmaltes.

El uso de barnices antes del proceso de lavados también es necesario. En este caso, independientemente del modelo, debemos elegir un acabado brillante o satinado, nunca uno mate para que el lavado funcione correctamente. Por otra parte cuando aplicamos un filtro, es conveniente hacerlo sobre una superficie mate para que se propague con facilidad.

Desde este punto, son los diferentes procesos de envejecimiento en sí mismos y los medios (óleos, esmaltes, pigmentos, acrílicos...) y la forma en que los usamos (filtros, lavados, envejecimiento, polvo...) sobre nuestro modelo lo que creará diferentes acabados en las diferentes áreas del modelo. Esta riqueza es algo que queremos, por lo que nunca debemos, bajo ninguna circunstancia, utilizar una capa de barniz general, que unificará el resultado y perderá toda su riqueza visual.



8.3 PRIMERS / IMPRIMADORES

3GEN RANGE GAMA 3 GENERACIÓN

AK11242
BLACK PRIMER
100 ml



AK11240
WHITE PRIMER
100 ml



AK11241
GREY PRIMER
100 ml



The latest generation primers are applied onto the plastic with perfect adhesion properties. Simply apply a thin coat that helps to break the surface tension between the plastic and the acrylic base paint. With a second layer we can cover everything perfectly and get a perfect paint grip.

Los imprimadores de última generación permiten ser aplicados sobre el plástico con perfectas propiedades de adhesión. Basta con aplicar una capa ligera que ayude a romper la tensión superficial entre el plástico y la pintura base acrílica. Con una segunda capa podemos cubrir todo perfectamente y obtendremos un perfecto agarre de la pintura.

BASIC LINE GAMA BÁSICA



AK175
GREY PRIMER
60 ml



AK176
DARK YELLOW PRIMER
60 ml



AK177
WHITE PRIMER
60 ml



AK178
BLACK PRIMER
60 ml



AK179
RUSSIAN PRIMER
60 ml



AK180
RED PRIMER
60 ml



AK181
DESERT SAND PRIMER
60 ml



AK182
OLIVE DRAB PRIMER
60 ml



AK184
RUST PRIMER
60 ml



AK185
TRACKS PRIMER
60 ml



3RD GEN, THE BEST ACRYLICS TO PAINT...

ALL!!

AK1120
MUD
BROWN

AK11001
WHITE

AK1095
OCHER
ORANGE

AK1042
VOLCANIC
YELLOW

AK11092
MATT RED

AK1137
BRITISH
UNIFORM
BASE

AK1230
RAL 8017
ROTBRAUN

AK1309
RAL 6003
OLIVGRÜN

AK1316
RAL 7028
DUNKELGELB
(INITIAL)

AK1140
GRASS
GREEN

AK11087
SCARLET
RED

AK1109
DARK
BROWN

PERFECT FOR BRUSH AND AIRBRUSH

THE ORIGINAL BRAND UNBEATABLE MODELING PRODUCTS



AK-INTERACTIVE.COM

8.4 GLUES & FIXERS/ PEGAMENTOS Y FIADORES



AK12001
QUICK CEMENT EXTRA THIN
40 ml

Special square anti rolling base.
Ultra-thin precision maxoma fiber brush
1. Special density.
2. Glue by capillary action, very quick drying.
The Quick Cement is the fastest and strongest glue on the market. Unlike other plastic adhesives it dries quickly and allows gluing by capillary action, being very effective in joining parts with little contact surface.
*Base especial antivuelco cuadrada.
Cepillo de fibra maxoma de precisión ultrafina.*
1. Densidad especial.
2. Pegamento por capilaridad, uniones muy rápidas.
El Quick Cement es el pegamento más rápido y más fuerte del mercado, a diferencia de otros adhesivos plásticos en el mercado, su secado es rápido y muy efectivo y permite pegar por capilaridad y es muy efectivo en superficies con poca superficie de contacto.



AK12002
EXTRA THIN CEMENT
40 ml

Special square anti rolling base.
Ultra-thin precision maxoma fiber brush
1. Special density.
2. Glue by capillary action, quick drying.
The Extra Thin Cement glues by capillary action with a medium / fast drying time. It is undoubtedly the best option for general assembly work.
*Base especial antivuelco cuadrada.
Cepillo de fibra maxoma de precisión ultrafina.*
1. Densidad especial.
2. Pegamento por capilaridad, uniones muy rápidas.
El extra fino para pegar por capilaridad con un tiempo de secado medio / rápido es, sin duda, la mejor opción para el trabajo de montaje general. Gran rendimiento con la viscosidad perfecta para modelar plástico.



AK12003
PLASTIC CEMENT
STANDARD DENSITY
40 ml

Special square anti rolling base.
1. Normal density and thicker maxoma fiber brush to glue.
2. Glue by contact, quick drying.
The classic modeling glue with medium drying time and more viscosity. It has a standard application brush for work on larger surfaces and general assembly. Great performance, is indicated for the assembly of plastic models and acts in a few seconds.
Base especial antivuelco cuadrada.
1. Densidad normal y cepillo de fibra de maxoma más grueso para pegar.
2. Pegamento por contacto, uniones rápidas.
El clásico pegamento de modelismo con un tiempo de secado medio y más viscosidad. Tiene una brocha de aplicación estándar para trabajar en superficies más grandes y como ensamblaje en general. Gran rendimiento, está indicado para el montaje de modelos de plástico y actúa en pocos segundos.



AK12004
EXTRA THIN CITRUS CEMENT
40 ml

Special square anti rolling base.
Ultra-thin precision maxoma fiber brush.
1. Special density.
2. Glue by capillary action, quick drying.
The Extra Thin Citrus Cement glues by capillary action with a medium / fast drying time, and has a mild citrus aroma. It is undoubtedly the best option for general assembly work. Great performance with the perfect viscosity for plastic modeling.
*Base especial antivuelco cuadrada.
Cepillo de fibra maxoma de precisión ultrafina.*
1. Densidad especial.
2. Pegamento por capilaridad, uniones muy rápidas.
El Extra Fino Cítrico tiene las características del pegamento extra fino pero con un aroma cítrico suave. Para pegar por capilaridad con un tiempo de secado medio / rápido, es sin duda la mejor opción para el trabajo de montaje general. Gran rendimiento con la viscosidad perfecta para modelar plástico.



AK12016
BLACK WIDOW ULTRA RESISTANT
CYANOACRYLATE GLUE 20g

Special cyanoacrylate 380 formulated with rubber particles to add flexibility to the joints. Extra strong, low viscosity, with a special formulation for metals, rubber and plastics. The surfaces to be joined must be free of dirt, dust and grease. A small amount of adhesive should be applied, more cyanoacrylate does not guarantee a better bond and makes more difficult the drying of the adhesive that is effective for bonding.
Cianoacrilato especial 380 formulado con partículas de caucho para agregar flexibilidad a las juntas, extra fuerte, baja viscosidad, con una formulación especial para metales, caucho y plásticos. Las superficies a unir deben estar libres de suciedad, polvo y grasa. Se debe aplicar una pequeña cantidad de adhesivo, más cianoacrilato no garantiza una mejor unión y dificulta el secado del adhesivo que es efectivo para la unión.



AK12015
MAGNET CEMENT CIANOACRILATO
99% CIANO 20g

General-purpose cyanoacrylate 401. Fast drying, extra strong, low viscosity, specially formulated for adhesion between materials that can even have an acidic surface. Can be used with rubber, leather, wood, metal, resin and plastic. The surfaces to be joined must be free of dirt, dust and grease. A small amount of adhesive should be applied; more cyanoacrylate does not guarantee a better bond and makes more difficult the drying of the adhesive that is effective for bonding.
Cianoacrilato de uso general 401, secado rápido, extra fuerte, baja viscosidad especialmente formulado para la adhesión entre materiales que incluso pueden tener una superficie ácida. Se puede usar con caucho, cuero, madera, metal, resina y plástico. Las superficies a unir deben estar libres de suciedad, polvo y grasa. Se debe aplicar una pequeña cantidad de adhesivo; más cianoacrilato no garantiza una mejor unión y hace más difícil el secado del adhesivo que es efectivo para la unión.

THINK, CREATE, GLUE

NEW GLUE RANGE FOR ALL MODELING GENRES



AK12026

FLASH – ACCELERATOR FOR CYANOACRYLATE GLUE 150 ml

CA-glue activator designed to reduce the bonding time to mere seconds. Especially useful for gluing elements with small contact surface.

Activador de pegamento cianocrilato diseñado para acelerar el tiempo de secado.

Especial para piezas con pequeña superficie de contacto.



AK12017

ERASER – CLEANER FOR CYANOACRYLATE GLUE EXCESS REMOVER 20g

Softens and removes already hardened cyanoacrylate adhesives. Ideal for small touches once the piece has been glued.

HOW TO USE:

Treat the surface to be cleaned by rubbing with paper towels dipped in ERASER cleaner.

Clean the surfaces, while they are damp, with paper towels, in order to eliminate the remains of the ERASER cleaner.

Ablanda y elimina los restos de cianocrilato secos.

Ideal para pequeños retoques una vez las piezas están secas.

MODO DE USO:

Trate la superficie a limpiar frotando con un papel humedecido en el Eraser Cleaner.

Limpie las superficies, mientras están húmedas, con un papel, para eliminar los restos del Eraser.



AK12014

WOLVERINE COLA BLANCA 100 ml

“Wolverine” is a white glue of high quality and high resistance with drying accelerator.

With all the properties of white glue and faster drying. Especially suitable for work on transparent parts and for resistant and invisible joints. To glue wood, paper, cardboard, cork, wicker, polystyrene, foam, etc. High viscosity extends very smoothly. It can be diluted with water to achieve the desired viscosity. Apply with temperatures between 10 and 35°C. and a relative humidity of 70% maximum. Total cure in 6 hours (According to room temperature and applied thickness).

Wolverine, es una cola blanca de alta calidad y alta resistencia con acelerante de secado. Con todas las propiedades de la cola blanca y un secado más rápido. Especialmente indicado para trabajos en piezas transparentes y para juntas resistentes e invisibles. Para pegar madera, papel, cartón, corcho, mimbre, poliestireno, espuma, etc. La alta viscosidad se extiende muy suavemente. Se puede diluir con agua para lograr la viscosidad deseada. Aplicar con temperaturas entre 10 y 35°C. y una humedad relativa del 70% como máximo. Curado total en 6 horas (según temperatura ambiente y espesor aplicado).



AK118

GRAVEL AND SAND FIXER 100 ml

This special adhesive, with an alcohol base, is much more effective than the traditional white glue. The white glue tends to leave a plastic finish over the surface giving an unreal aspect and also tends not to expand well through the material. This product is easily cleaned using alcohol, can be applied using an airbrush or paint brush.

Este adhesivo especial, con una base de alcohol, es mucho más efectivo que la cola blanca tradicional. La cola blanca tiende a dejar un acabado plástico sobre la superficie dando un aspecto irreal y también tiende a no expandirse bien a través del material. Este producto se limpia fácilmente con alcohol, se puede aplicar con aerógrafo o pincel.



AK048

PIGMENT FIXER 35 ml

Recommended product to adhere pigments to the surfaces of your models and bases. Use capillary action to allow fluid to flow over pigment powder. Once dried, pigments are permanently adhered to the surface and return to dry color.

Producto recomendado para adherir pigmentos a las superficies de sus modelos y bases. Use el efecto capilaridad para permitir que el fluido fluya sobre el pigmento en polvo. Una vez secos, los pigmentos se adhieren permanentemente a la superficie y vuelven al color seco.

8.5 AK SPECIALS / ESPECIALES DE AK



AK737

DRYING RETARDER 60 ml

Liquid to slow down the drying times for any acrylic paint. To use simply add a few drops to your airbrush and will prevent fast drying at the tip of the airbrush especially in high temperature conditions.

Also can be used to apply with brush to get glazing effects, or just delay dry in a controlled way. Non-toxic and odorless.

Líquido para ralentizar los tiempos de secado de cualquier pintura acrílica. Para usarlo, simplemente agregue unas gotas a su aerógrafo y evitará un secado rápido en la punta del aerógrafo, especialmente en condiciones de alta temperatura.

También se puede usar para aplicar con brocha para obtener efectos de acristalamiento, o simplemente retrasar el secado de una manera controlada. No tóxico y sin olor.



AK186

PAINT STRIPPER 100 ml

pag. 163

The definitive liquid to strip the paint completely or selectively from models or figures without damaging the plastic, resin or white metal.

El líquido definitivo para retirar la pintura completa o selectivamente de modelos o figuras sin dañar el plástico, la resina o el metal blanco.



AK582

DECAL ADAPTER SOLUTION 100 ml

Liquid to adapt your decals to any surface. After applying the decal in desired position, wet the decal with the solution, using a brush. Leave it for a few minutes, then with the help of a brush, adapt it to the surface to fully integrate it. With this product no decal will resist, no matter how complicated the surface will be. And only with one product!

Líquido para adaptar tus calcas a cualquier superficie. Moje la calca con la solución y un pincel después de colocarla. Dejar unos minutos, luego con la ayuda del pincel, adaptarlo a la superficie para integrarlo completamente. Con este producto, ninguna calca se resistirá, sin importar cuán complicada sea la superficie. ¡Y solo con un producto!



AK893
GAUZY AGENT COAT 100 ml pag. 181

High quality product developed to enhance, repair, and achieve extremely realistic transparent glass-like finishes on clear plastic parts. Simply dip and let dry for a few minutes. For best results, allow product to dry in a dust-free environment. *Producto de alta calidad desarrollado para mejorar, reparar y lograr acabados de vidrio transparente extremadamente realistas en piezas de plástico transparente. Simplemente sumerge y deje secar por unos minutos. Para mejores resultados, deje que el producto se seque en un ambiente libre de polvo.*



AK894
INTERMEDIATE GAUZY AGENT SHINE ENHANCER 100 ml pag. 182

High quality product to create a protective and very realistic glossy sheen to areas where applied. This product also serves as a protective layer for the paint underneath. Apply in the way you would with any varnish. Apply and let dry for a few minutes. With self-leveling properties, it can be applied with brush or airbrush. *Producto de alta calidad para crear un brillo satinado protector y muy realista en las áreas donde se aplica. Este producto también sirve como una capa protectora para la pintura debajo. Aplicar de la forma que lo haría con cualquier barniz. Aplicar y dejar secar unos minutos. Tiene propiedades de autonivelación, se puede aplicar con pincel o aerógrafo.*



AK236
WASHABLE AGENT 100 ml pag. 164

A special product which converts any acrylic paint into washable paint. This product is recommended for winter camouflage, creating dust effects, or to imitate the low quality paint layers. The result is very convincing as it is based on the same principle as real paint. The possibilities are endless because the product can be used with any color. Add 10% of this product to your acrylic paint to make it washable. Once the mix is applied, you can remove the desired quantity with a brush moistened in water. *Super producto especial que convierte cualquier pintura acrílica en lavable, imagine en los efectos que se pueden lograr en cualquier tipo de maqueta. Desarrollado por AK y ninguna otra marca tiene este producto. Agregue un 10% de este producto a su pintura acrílica para que sea lavable. Una vez que se aplica la mezcla, puede eliminar la cantidad deseada con un pincel humedecido en agua.*



AK159
METAL BURNISHING FLUID 100 ml pag. 161

A new faster formula (works in seconds), and at a more competitive price. With our Metal Burnishing fluid, you can naturally weather and 'rust' white metal tracks, such as those made by AK-Interactive or Friulmodel. Just dip the tracks in the liquid for a few seconds and the metal will begin to appear dark and rusty very quickly, easily and effortlessly. You can vary the effect using different dilutions and varying lengths of soak. *Una nueva fórmula más rápida (funciona en segundos) y a un precio más competitivo. Hemos probado y formulado exhaustivamente para mejorar este producto. Con nuestro fluido para metales, naturalmente, puede desgastar y oxidar cadenas de metal blanco, como las hechas por Friulmodel o las nuestras. Simplemente sumerja las cadenas en el líquido durante unos segundos y el metal comenzará a aparecer oscuro y oxidado muy rápido, fácil y sin esfuerzo. Puede variar el efecto utilizando diferentes diluciones y diferentes tiempos de inmersión. Usando menos producto, puede lograr incluso mejores resultados que con nuestra fórmula anterior.*



AK174
PHOTOETCH BURNISHING 100 ml pag. 162

New formula, improved, faster and at a more competitive price. This liquid will darken photo-etch brass parts, and also machine gun and tank barrels. The end result with brass parts is a finish which is very similar to steel. It is highly recommended that you darken your photo-etch parts before use. *Nueva fórmula, mejorada, más rápida y a un precio más competitivo. Este líquido se oscurecerá las piezas de latón fotográficas, y también barriles de ametralladoras y cañones de tanque. El resultado final con piezas de latón es un acabado muy similar al acero. Es muy recomendable oscurecer las partes de fotográficas antes de usar para una mejor adherencia a la pintura.*



AK088
WORN EFFECTS FLUID 35 ml pag. 155

Odorless acrylic product intended for the creation of various chipping effects that can effectively eliminate the need for hairspray, which yields inconsistent results due to different chemical formulas and properties, from one brand to another. To create the chipping effects, we first paint our model with a color that we want to see under the scratches. Next, we apply a generous coat of Worn Effects fluid, using an airbrush or a brush. Afterwards, we apply the base color. Once the base color is dry, we dampen the surface with water and gently rub away the paint to reveal the undercoat. For this operation you can use different types of brushes, toothpicks, needles, etc. Each generates a different kind of chip effect. We recommend using AK088 Worn Effects for the more subtle chips and scratches. *Producto acrílico inodoro y efectivo para reemplazar la laca de pelo y hacer efectos de desgaste y descomchones en nuestros modelos. Primero pintamos nuestro modelo con un color oscuro o el color que queremos ver debajo de los rasguños. Posteriormente, podemos aplicar directamente con un aerógrafo dando una capa generosa sobre nuestro modelo. Luego, utilizando una pintura acrílica, podemos hacer pequeños efectos de daños. Humedezca la superficie con un pincel y luego haga los efectos con una herramienta afilada o el mismo pincel. No juegue con ninguna laca antigua y confíe el resultado de su modelo a este producto. El producto AK es el original y el primero en el mercado.*



AK089
HEAVY CHIPPING FLUID 35 ml pag. 156

Odorless acrylic product intended for the creation of various chipping effects that can effectively eliminate the need for hairspray, which yields inconsistent results due to different chemical formulas and properties, from one brand to another. To create the chipping effects, we first paint our model with a color that we want to see under the scratches. Next, we apply a generous coat of Heavy Chipping fluid, using an airbrush or a brush. Afterwards, we apply the base color. Once the base color is dry, we dampen the surface with water and gently rub away the paint to reveal the undercoat. For this operation you can use different types of brushes, toothpicks, needles, etc. Each generates a different kind of chip effect. We recommend using AK089 Heavy Chipping for large chips. *Producto acrílico inodoro y efectivo para reemplazar la laca de pelo y hacer efectos de desgaste y rayones en nuestros modelos. Primero pintamos nuestro modelo con un color oscuro o el color que queremos ver debajo de los rasguños. Posteriormente, podemos aplicar directamente con un aerógrafo una capa generosa sobre nuestro modelo. Luego, utilizando una pintura acrílica, podemos hacer efectos grandes de daño. Humedezca la superficie con un pincel y luego haga los efectos con una herramienta afilada o el mismo pincel. No juegue con ninguna laca antigua y confíe el resultado de su modelo a este producto. El producto AK es el original y el primero en el mercado.*



AK8200
ANTI-SLIP TEXTURE

Two-component product to create realistic anti-slip texture in scale models:
1. Spread the adhesive liquid over the previously delimited surface of the model.
2. Pour the silica over the surface covered with cement. Make sure you cover the entire work area.
3. Remove the excess sand. The anti-slip texture is ready for priming.

Producto de 2 componentes para crear una textura antideslizante realista en modelos a escala.
1. Extender el adhesivo líquido sobre la superficie del modelo previamente delimitada.
2. Vierta la sílice sobre la superficie cubierta con el adhesivo. Asegúrese de cubrir toda la zona donde irá el antideslizante.
3. Retire el exceso de arena. La textura antideslizante está lista para imprimación.



8.6 PUTTY & PASTE/ MASILLAS Y TEXTURAS



AK897
EASY CAST TEXTURE 75 ml pag. 187

Product to create texture of cast in any plastic, resin or metal part of your model. Just open, apply and let dry. Your models will have a completely different appearance.

Producto para crear textura de fundición en cualquier parte de plástico, resina o metal de su modelo. Simplemente abra, aplique y deje secar. Sus modelos tendrán una apariencia completamente diferente.



AK103
MODELING WHITE PUTTY HARD

High quality white acrylic putty, extra hard, (20 ml, 39 gr). Polyurethane, water-based. Does not shrink when drying. Specially designed for modeling. Superfine filler with perfect adhesion and sanding properties. It is water-based so there are no smelly chemicals in the mix to cause skin and respiratory problems. It can be cleaned off with water.

Masilla acrílica blanca de alta calidad, extra dura, (20 ml, 39 gr.). Poliuretano a base de agua. No se merma al secar. Especialmente desarrollada para el modelismo. Relleno superfino con perfecta adherencia y propiedades de lijado. Es a base de agua, por lo que no hay productos químicos malolientes en la mezcla que causen problemas respiratorios y en la piel. Se puede limpiar con agua.



AK104
MODELING GREY PUTTY STANDARD

High quality grey acrylic putty, standard hardness, (20 ml, 39 gr). Polyurethane, water-based. Does not shrink when drying. Specially designed for modeling. Superfine filler with perfect adhesion and sanding properties. It is water-based so there are no smelly chemicals in the mix to cause skin and respiratory problems. It can be cleaned off with water.

Masilla acrílica blanca de alta calidad, dureza estándar, (20 ml, 39 gr.). Poliuretano a base de agua. No se merma al secar. Especialmente desarrollada para el modelismo. Relleno superfino con perfecta adherencia y propiedades de lijado. Es a base de agua, por lo que no hay productos químicos malolientes en la mezcla que causen problemas respiratorios y en la piel. Se puede limpiar con agua.



AK665
TEXTURIZER ACRYLIC RESIN 100 ml
pag. 170

High quality acrylic resin intended for mixing with pigments to fix textures, with a matte finish. TEXTURIZER can be used to create terrains and splatter effects.

Botella de 100 ml. Resina acrílica de alta calidad para mezclar con pigmentos para fijar texturas y con un acabado mate. TEXTURIZER se puede utilizar para hacer terrenos y efectos de salpicaduras en partes bajas de vehículos.



AK617
WEATHERING PLASTER BASE 100 ml

A must have product for any modeler who wants to add volume to his/her mud and soil mixtures intended for a diorama or to be splashed onto a vehicle. Mix the plaster with any of our high quality Nature Effects products to create different types of mud, earth, dust and soil. The combinations are endless. If your mixture is too thick, you can dilute it with white spirit. If is too thin, add more plaster.

Un producto imprescindible para cualquier modelista que quiera aportar volumen a sus mezclas de lodo y tierra, ya sea para un diorama o para hacer salpicaduras en un vehículo. Mezcla el yeso con cualquiera de nuestra línea de efectos de naturaleza de diferentes tipos de lodo, polvo y tierra. Las combinaciones son infinitas. Si tu mezcla es demasiado espesa, puedes diluirla con White Spirit. Si es demasiado líquida, agrega más yeso. Pinta tu mezcla en tu diorama o carga un pincel con tu mezcla y con tu aerógrafo, sopla breves ráfagas de aire en el pincel para recrear las salpicaduras.



AK9050
DETAIL SHINE ENHANCER

Detail Shine Enhancer is a special modeling wax developed to create extra shine on certain objects and add more richness to the colors. It can be used on models, dioramas and vignettes, allowing you to achieve different effects on small surfaces, such as grease or wet effects on canvas or floor tiles. With this product, you can easily add ultra-realistic touches to your model without having to use a varnish.

Este producto ha sido desarrollado para aportar un aspecto brillante selectivamente en algunas aristas y piezas de las maquetas, tales como toldos, lonas, ropas, etc. No es un barniz satinado y no funciona como tal, es una base cera incolora que puede aplicarse con el dedo consiguiendo mates muy realistas en ciertos materiales.



AK8208
GREENPOWER 2 COMPONENT
MODELING PUTTY

GREENPOWER is an epoxy putty that when both components are mixed at room temperature, allows for the creation of anything you like! Once both components are mixed, the result is a sticky green putty. At this point, you have about 90 minutes to mold and detail, reaching maximum hardness after 24 hours. To obtain smoother surfaces, it is recommended to use a lubricant such as water, oil, or Vaseline, in order to prevent unwanted settling of the putty. The tools must always be lubricated or moistened, and talcum powder can be used to avoid fingerprints, or to add texture. Altering the proportions of both components produces a greater or lesser hardness and a faster or slower hardening time. Storing the putty in a cool area or even in the refrigerator will keep it in better condition, and it will last longer.

This product contains 2 x 10cm stripes of putty. GREENPOWER es una masilla epóxica que cuando se mezclan ambos componentes a temperatura ambiente permite recrear cualquier pieza. Una vez mezclados ambos componentes, el resultado se convierte en una masilla verde pegajosa. Luego tienes aproximadamente 90 minutos para moldear y detallar, alcanzando la máxima dureza después de 24 horas.

Para obtener superficies más suaves, se recomienda usar un lubricante como agua, aceite o vaselina para evitar la sedimentación no deseada de la masilla. Las herramientas deben estar siempre lubricadas o humedecidas, y se puede usar talco en polvo para evitar las huellas dactilares o para agregar textura. La alteración de las proporciones de ambos componentes produce una mayor o menor dureza y un endurecimiento más rápido o más lento. Almacenar la masilla en un lugar fresco o incluso en el refrigerador la mantendrá en mejores condiciones y durará más tiempo. Este producto contiene 2 tiras de 10cm de masilla.

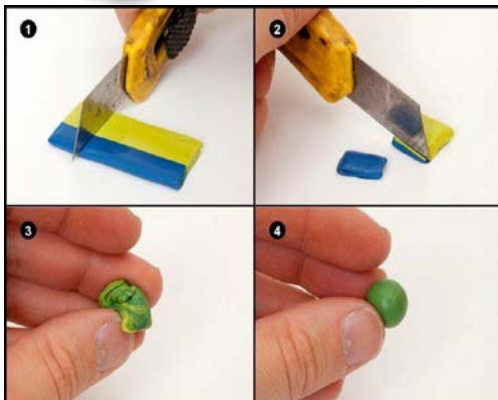

9

TOOLS & ACCESORIES/ HERRAMIENTAS & ACCESORIOS

In this range you will find some very useful tools that stand out from comparable products thanks to their quality.
En esta gama encontrará algunas herramientas y accesorios muy útiles que destacan de productos similares gracias a su calidad.

9.1 PAINT TOOLS / HERRAMIENTAS PARA PINTAR



AK612
ALUMINUM
PALETTE 6 WELLS



AK613
ALUMINUM PALLET
12 WELLS



AK9014
SIX WELLS TRAY



AK614
SMALL PIPETTES
12 UNITS



AK615
MEDIUM PIPETTES
7 UNITS



AK892
STAINLESS STEEL
SHAKERS (250)



AK616
MIX N' READY 35 ml



AK505
MIX N' READY 17 ml



AK620
MIX N' READY GLASS 10 ml



AK8206
MODELING PAINT
WELLS



AK8207
STIRRING BARS



AK9048
PAINT DOSER BOTTLES
3X100ML

Set of three 100ml bottles with a doser and a comfortable screw closure. It includes a crystal ball for shaking the paint better. The transparent PVC allows to see the color of the paint directly.
Juego de tres botellas de 100ml con dosificador y cómodo cierre a rosca. Incluye una bola de cristal para agitar mejor la pintura. El PVC transparente permite ver el color de la pintura directamente.



AK9047
PAINT DOSER BOTTLES
4X60ML

Set of four 60ml bottles with a doser and a comfortable screw closure. It includes a crystal ball for shaking the paint better. The transparent PVC allows to see the color of the paint directly.
Juego de cuatro botellas de 60ml con dosificador y cómodo cierre a rosca. Incluye una bola de cristal para agitar mejor la pintura. El PVC transparente permite ver el color de la pintura directamente.



100ml



60ml



30ml



AK9046
PAINT DOSER BOTTLES
4X30ML

Set of four 30ml bottles with a doser and a comfortable screw closure. It includes a metal ball to stir the paint better. The transparent PVC allows to see the color of the paint directly.
Juego de cuatro botellas de 30ml con dosificador y cómodo cierre a rosca. Incluye una bola de metal para agitar mejor la pintura. El PVC transparente permite ver el color de la pintura directamente.

9.2 MODELING TOOLS / HERRAMIENTAS PARA MODELAR

AK9169 MULTIFUNCTION BAR TOOL FOR PUTTY



This is one of the essential tools for a scale modeling workbench. This straight stainless steel spatula is a perfect tool for the application of putty and distributing it in a precise manner. Also useful for mixing and stirring. It is easy to clean and very resistant.

Esta es una de las herramientas imprescindibles en una mesa de modelismo. Esta espátula recta de acero inoxidable es una herramienta perfecta para la aplicación de masilla o para extenderla de forma precisa. También es útil para mezclar y revolver. Fácil de limpiar y muy resistente.



AK9051 SET DE ESPÁTULAS PARA MODELISMO



Auxiliary spatulas set. A very interesting tool when tackling both sculpting and carving work as well as the construction of vignettes and dioramas. It helps to spread and level the paste on the surface where we want to place our vehicle or figure and on the walls of buildings.

Use the spatulas also to help you sprinkle the sand on the putty or to distribute the pigments, even to extract them comfortably from their cans without staining yourself. With its different designs you will always find the ideal spatula for each job.

Juego de espátulas auxiliares. Una herramienta muy interesante a la hora de abordar tanto trabajos de escultura como tallado, así como la construcción de viñetas y dioramas. Ayuda a esparcir y nivelar la pasta en la superficie donde queremos colocar nuestro vehículo o figura y en las paredes de los edificios. Utiliza las espátulas también para ayudarte a espolvorear la arena sobre la masilla o para distribuir los pigmentos, incluso para extraerlos cómodamente de sus latas sin mancharse. Con sus diferentes diseños siempre encontrarás la espátula ideal para cada trabajo.

AK9052 SET DE PUNZONES PARA ESCULPIR

Sculpting burnishers, an ideal tool for shaping putty in conjunction with the Carving Tools. Five pieces with different tips to always have the precise tool.

Also use these punches to make headlights by pressing the tip over a tin foil placed on a soft surface. Burnish small pieces of leather for belts and straps on large scales. You can simulate shrapnel impacts and small craters on your scenes.

Punzones para esculpir, una herramienta ideal para dar forma a la masilla junto con las herramientas para tallar. Cinco piezas con puntas diferentes para tener siempre la herramienta precisa. También use estos punzones para hacer faros presionando la punta sobre un papel de aluminio colocado sobre una superficie blanda. Lustra pequeñas piezas de cuero para cinturones y correas a gran escala. Puede simular impactos de metralla y pequeños cráteres en sus escenas.

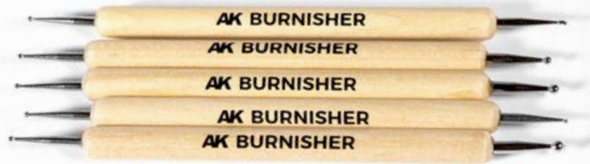

AK9005 CARVING TOOLS DELUXE BOX

These four tools can be used to carve the foam and for modeling of figures and accessories. They have the most useful types of tips for carving and shaping your models, bases, foams and other materials. These tools are made of stainless steel and it is recommended to always wash them with soap and water after using these with any material, and dry them well with a soft cloth. This set comes in a handy and solid aluminium box.

Estas cuatro herramientas pueden usarse para tallar el foam y para el modelado de figuras. Tienen los tipos de puntas más útiles para poder realizar todo tipo de efectos en la talla y en el modelado. Estas herramientas son de acero inoxidable y es recomendable lavarlas con agua y jabón siempre después de usar estas con cualquier material y secarlas bien con un paño suave. Se presentan en una práctica y sólida caja de aluminio.



9.2.1 SILICONE BRUSHES / PINCELES DE SILICONA

Silicone-tip brushes. Two hardnesses and two sizes.

The perfect tool when undertaking any modeling job. Also suitable for applying oil glazes on flat vehicle surfaces.

The white-tipped ones are normal hardness and the black-tipped ones are slightly higher hard. Suitable for any modeling putty, Apoxie Sculpt, Greenpower, Milliput, Sculpey, Fimo, etc.

Use water, alcohol or vaseline as a softening agent to prevent the putty from sticking to the tip of the brush, extend its life by rinsing them regularly with soap and water gently. The variety of tips in the set will make it easy for you to tackle any type of job.

Pinceles con punta de silicona. Dos durezas y dos tamaños. La herramienta perfecta para realizar cualquier trabajo de modelado. También adecuado para aplicar barnices de aceite en superficies planas de vehículos. Los de punta blanca son de dureza normal y los de punta negra son un poco más duros. Apto para cualquier masilla de modelar, Apoxie Sculpt, Greenpower, Milliput, Sculpey, Fimo, etc. Utilice agua, alcohol o vaselina como agente suavizante para evitar que la masilla se pegue a la punta del pincel, alargue su vida enjuagándolos regularmente con jabón y agua suavemente. La variedad de formas del set le facilitará la realización de cualquier tipo de trabajo.



AK9085
SILICONE BRUSHES MEDIUM TIP SMALL
(5 SILICONE PENCILS)



AK9086
SILICONE BRUSHES MEDIUM TIP MEDIUM
(5 SILICONE PENCILS)



AK9087
SILICONE BRUSHES HARD TIP SMALL
(5 SILICONE PENCILS)



AK9088
SILICONE BRUSHES HARD TIP MEDIUM
(5 SILICONE PENCILS)



9.3 TOOLS / HERRAMIENTAS



AK9007
PRECISE CURVED
TWEEZERS



AK9008
PRECISE
STRAIGHT
TWEEZERS



AK9161
HG ANGLED TWEEZERS 01
THIN TIPPED

Size: 140 mm long. High-precision tweezers specially designed for scale modelling purposes. They allow to grab and hold small parts and handle them with precision. Our tweezers are made of stainless steel with a polished surface, providing an extremely delicate and smooth feel. Their thickness guarantees the stability of the tweezers during use. The arch-shaped design ensures a good grip on the workpiece.

Tamaño: 140 mm de largo. Pinza de alta precisión especialmente diseñada para el modelista. Las pinzas de alta precisión AK sirven para sujetar piezas pequeñas o cualquier trabajo que requiera precisión. La pinza está hecha de acero inoxidable con la superficie pulida, lo que brinda una sensación extremadamente delicada y suave. Su grosor garantiza la estabilidad de las pinzas durante su uso. El diseño en forma de arco asegura una buena sujeción de la pieza a manejar.



AK9162
HG ANGLED TWEEZERS 02
FLAT-END

Size: 140 mm long. High-precision tweezers specially designed for scale modelling purposes. They allow to grab and hold small parts and handle them with precision. Our tweezers are made of stainless steel with a polished surface, providing an extremely delicate and smooth feel. Their thickness guarantees the stability of the tweezers during use. The arch-shaped design ensures a good grip on the workpiece.

Tamaño: 140 mm de largo. Pinza de alta precisión especialmente diseñada para el modelista. Las pinzas de alta precisión AK sirven para sujetar piezas pequeñas o cualquier trabajo que requiera precisión. La pinza está hecha de acero inoxidable con la superficie pulida, lo que brinda una sensación extremadamente delicada y suave. Su grosor garantiza la estabilidad de las pinzas durante su uso. El diseño en forma de arco asegura una buena sujeción de la pieza a manejar.



AK9013
BASIC TOOLS SET

Basic toolkit for beginners, advanced modelers or anyone interested in this hobby that requires precision tools.

It includes:

- Straight tweezers
- Cutting pliers
- Cutter with replacement blades and safety cap
- Metal file

Set de herramientas básicas para principiantes, modelistas avanzados o para cualquier persona interesada en este hobby que requiera herramientas de precisión.

Incluye:

- Pinzas rectas
- Alicata de corte
- Cúter con hojas de recambio y tapón de seguridad
- Lima de metal



AK9012
SIDE CUTTER



AK9009
PLIER



AK9006
HAND DRILL

Precision hand drill made of aluminum alloy and lacquered in black with the brand logo, valid for drill bits from 0.2 to 3.4mm. A very practical, precise and very efficient tool for all types of holes in the models or in any craft and jewelry work.

Taladro de mano de precisión fabricado en aleación de aluminio y lacado en negro con el logo de la marca, válido para brocas desde 0.2 a 3.4mm. Una herramienta muy práctica, precisa y muy eficiente para todo tipo de agujeros en los modelos o en cualquier trabajo de artesanía y joyería.



AK9043
QUICK CHANGE
DRILL BITS
MEDIUM

Set of ten carbide drill bits ranging from 0.4mm up to 1.3mm. They have a stem of the same measure to facilitate its use in any type of drill holder.

Set de diez brocas de carburo que van desde 0.4mm hasta 1.3mm y que tienen un vástago de la misma medida para facilitar su uso en cualquier tipo de porta-brocas.



AK9168
SCISSORS
SPECIAL FOR
PHOTOETCHED PARTS

This is one of the essential tools for a scale modeling workbench. Special scissors for cutting photo-etched parts. They have a long arm and a curved tip to apply more force and to make a precise cut.

Esta es una de las herramientas imprescindibles en una mesa de modelismo. Tijeras especiales para fotograbados. Poseen un brazo largo y punta curva para aplicar más fuerza y realizar un corte preciso.



AK9011B
CUTTER 20 SPARE BLADES

Precision cutter with 20 Replacement Blades. The metal handle has a non-slip grip surface and is lacquered in a black color with the AK logo. It is comfortable, lightweight and easy to control. It contains a safety hood to protect the blade and prevent accidents. The blades are extremely sharp and durable.

Size of the grip surface: 36mm.

Cúter de precisión con 20 Cuchillas de Repuesto. El mango metálico tiene una superficie de agarre antideslizante y está lacado en un color negro con el logo de AK. Es cómodo, ligero y fácil de controlar. Contiene una capucha de seguridad para proteger la cuchilla y evitar accidentes. Las cuchillas son extremadamente afiladas y duraderas.

Tamaño de la superficie de agarre: 36mm.



AK9011
CUTTER



AK8058
GLASS FIBRE PENCIL



AK8065
3 GLASS FIBRE REFILL



AK1050
SPRAY CRAFT SPRAY CAN TRIGGER GRIP



Adaptable gun to spray paint or varnishes. Easy to control trigger for precise spray coverage and pressure control. No more finger strain or paint covered hands. Can be used with gloves. Comfortable trigger grip securely clamps onto can. Universal Fit: fits all standard spray cans.

Pistola adaptable para pintura en aerosol o barnices. Gatillo fácil de controlar para una cobertura de pulverización precisa y control de presión. No más esfuerzo en los dedos ni pintura en las manos cubiertas. Se puede usar con guantes. El cómodo gatillo se sujeta de forma segura a la lata. Ajuste universal: se adapta a todas las latas de aerosol estándar.



AK9166
PROFESSIONAL UNIVERSAL
HOLLOW HANDLE 0-14MM

High quality tool intended for making holes of a diameter up to 14 mm in plastic, PVC, resin, wood or aluminium and brass sheet. The perforations in the handle allow a long shank to pass through to facilitate turning when working with somewhat hard or thicker materials.

Herramienta de precisión para realizar todo tipo de agujeros en piezas de plástico, forex, resina, madera o aluminio y latón en láminas. Con dimensiones de 0 a 14 mm. Las perforaciones del mango permiten hacer pasar un vástago largo para facilitar el giro a la hora de trabajar con materiales algo duros o de mayor grosor.

AK9167
BEARING DISMANTLE TOOL

Precision tool to make circular pieces or for bending PE curved parts. Great versatility thanks to the number of diameters available, 2, 3, 4, 5, 6, 8, 10, 12 and 14mm. Simple is better. Material: Aluminio Eloxado

Herramienta de precisión para hacer piezas circulares o para doblar piezas curvas de fotograbado. Gran versatilidad gracias a la cantidad de diámetros disponibles, 2, 3, 4, 5, 6, 8, 10, 12 y 14mm. Simple es mejor. Material: Aluminio Eloxado

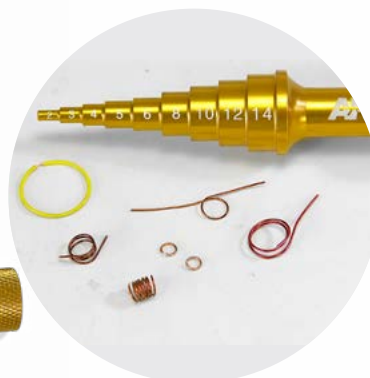

AK9163
PHOTO ETCHED ROLLING SET

Tool for shaping photo-etched parts, thin aluminum sheet or other malleable materials. The rolling rods are made of stainless steel. The base is made of an aluminum alloy and is finely carved. The surface received anodizing and sandblasting treatment. In the model making and detailing process, we often need to make cylindrical parts or shape photo-etched parts; with this tool, greater efficiency is achieved and cylindrical photo-etched parts can be easily manufactured.

Herramienta para dar forma a fotograbados, chapas finas de aluminio o materiales maleables. Los cilindros están hechos de acero inoxidable. La base está hecha de una aleación de aluminio y está finamente tallado. La superficie tiene un tratamiento de anodizado y pulido con chorro de arena. En el proceso de fabricación y detallado de maquetas, a menudo necesitamos hacer partes cilíndricas o dar forma a los fotograbados. Con esta herramienta se consigue mayor eficiencia y se pueden fabricar fácilmente piezas cilíndricas de fotograbado.

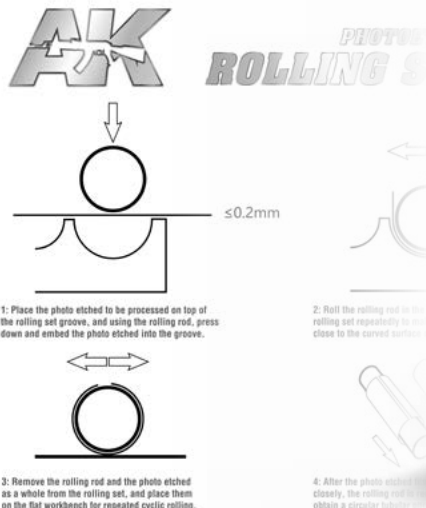

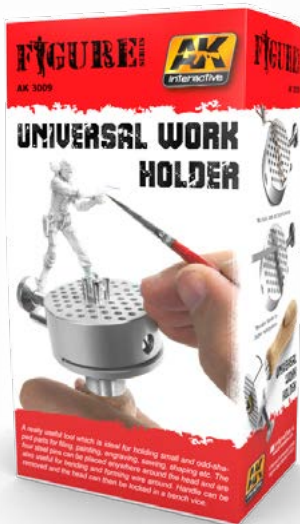

AK3009
UNIVERSAL WORK
HOLDER



AK9165
UNIVERSAL WORK HOLDER WITH HEAVY
BASE

Versatile aluminum holder allows hands free use while engraving, repairs, sanding or painting. Weigh 715 gr. Make this a handy workbench aid. The four movable pins allow for secure grip on large and small pieces. Sturdy heavy base and easy adjustment knobs. Comes with 8 steel pins can be placed anywhere on the head to accommodate various shapes. Ideal for bending and forming wire.

El soporte de aluminio versátil permite usarlo con las manos libres mientras graba, repara, lija o pinta. Pesa 715 gr. Convierta esto en una práctica ayuda para el banco de trabajo. Los cuatro pasadores móviles permiten un agarre seguro en piezas grandes y pequeñas. Base robusta y pesada y perillas de fácil ajuste. Viene con 8 clavijas de acero que se pueden colocar en cualquier lugar para adaptarse a varias formas. Ideal para doblar y manejar alambre.

AK9100
BASE FOR METAL PAINTING CLIPS

Size: 170x270 mm.
Painting clips not included (AK9127)
High quality compressed cardboard base for painting clips.
Tamaño: 170x270 mm.

*Pinzas de sujeción para piezas no incluidas (AK9127)
Cartón comprimido de alta calidad para usar como base para colocar las pinzas.*

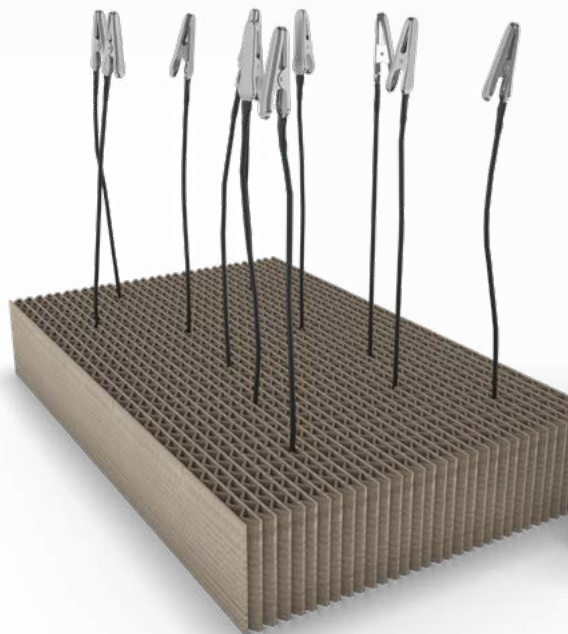

AK9127
METAL PAINTING CLIPS

20 units of metal alligator clips with the sticks and tips made from plastic, allowing for better grip without damaging the held pieces.
*Intended for clamping parts for the painting phase.
*The tweezers are covered with a plastic layer to avoid damaging the parts.
*The grip of the tweezers is precise so as not to damage the parts and hold them firmly at the same time.
*The length of the cane allows a comfortable grip away from the paint.
*Materials designed for a long service life.
*Suitable for any scale.
*If they are fixed to a base, they allow for having free hands during the painting process.
*Work faster and easier.

20 pinzas de Metal cocodrilo Clip Stick con plástico en la punta para mejor agarre sin daño en las piezas.
*Destinado a sujetar piezas para la fase de pintura.
*Las pinzas están cubiertas con una capa de plástico para evitar dañar las piezas.
*El agarre de las pinzas es preciso para no dañar las piezas y sujetarlas firmemente al mismo tiempo.
*La longitud del bastón permite un agarre cómodo lejos de la pintura.
*Materiales diseñados para una larga vida útil.
*Apto para cualquier escala.
*Si se fijan a una base, permiten tener manos libres durante el proceso de pintura.
*Trabaja más rápido y más fácil.

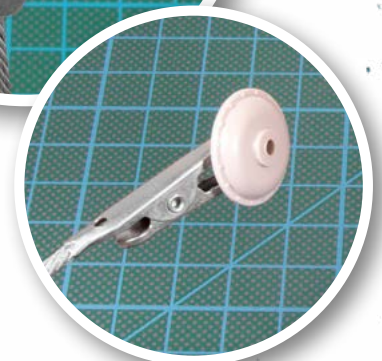

**AK8209-A3
AK8209-A4
MODELING CUTTING MAT
MANTEL DE CORTE**

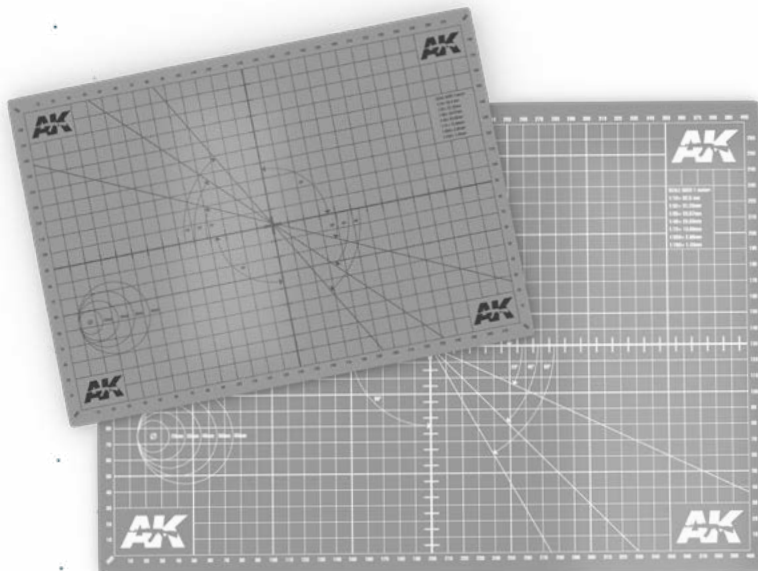

Tamaño A3: 450 x 300 mm.
Tamaño A4: 300 x 220 mm.

Modeling cutting mat.

- It is a five-layer recycled PVC cutting mat to try to meet the ecology demands that we must respect.
- 3mm thickness.
- Two soft outer layers and a hard white inside.
- It has self-healing power, superficial cuts tend to close over time.
- The selected color is a neutral one so that people can take photographs on their surface with a minimum incidence of the background on the model.
- This grid is printed in two different shades on each face, a light and a darker one, so that each person can choose the one that best suits their vision or working conditions, this is currently a unique feature of our cutting mats.

Mantel de corte para modelismo.

- Es un mantel de cinco capas de PVC reciclado para intentar atender a las demandas ecológicas que debemos respetar.
- 3mm de grosor.
- Las dos capas exteriores son blandas y la interior blanca es dura.
- Tiene poder auto-curativo, los cortes superficiales tienden a cerrarse con el tiempo.
- El color seleccionado es un color neutro para que la gente pueda realizar fotografías en su superficie con la mínima incidencia de este color de fondo sobre el modelo.
- Esta cuadrícula está impresa en dos tonos diferentes en cada cara, una clara y una más oscura, con el fin de que cada persona pueda elegir la que se adapta mejor a su visión o a sus condiciones de trabajo. Esto de momento es una característica única de nuestros manteles.

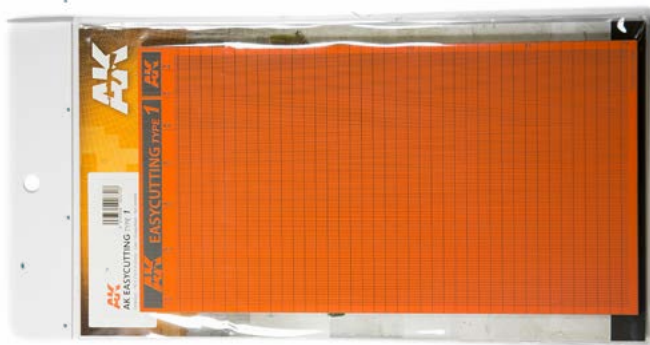

**AK8056
EASY CUTTING TYPE 1**

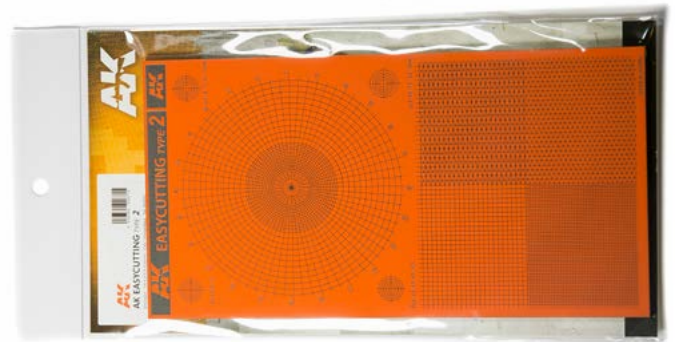

**AK8057
EASY CUTTING TYPE 2**

AK9049

**METALLIC MULTI SCALE TRIANGULAR RULER
CENTIMETERS, INCHES, 1/35, 1/72 AND 1/48 PLUS A CENTERED CENTIMETERS SCALE
REGLA TRIANGULAR METÁLICA MULTI ESCALA
CENTIMETROS, PULGADAS, 1/35, 1/72 Y 1/48 MÁS UNA ESCALA DE CENTIMETROS CENTRADOS**

This aluminum scale is perfect for different jobs and a very useful tool on the model table. It contains different scales to measure pieces in 1:48, 1:72, 1:35, Inches and centimeters.

Esta báscula de aluminio es perfecta para diferentes trabajos y una herramienta muy útil en la tabla de modelos. Contiene diferentes escalas para medir piezas en 1:48, 1:72, 1:35, pulgadas y centímetros.



APPLICATIONS AND RECOMMENDATIONS

Asides from measuring this tool has various other uses:

APLICACIONES Y RECOMENDACIONES

Además de medir esta herramienta tiene varios otros usos:

1.- Can be used as a helping tool for bending photo-etched parts.
1.- Se puede utilizar como herramienta de ayuda para doblar piezas fotográficas.

2.- Using plastic rulers as the guides for cutting can end up breaking the ruler and messing up our work.
2.- Usar reglas de plástico como guías para cortar puede terminar rompiendo la regla y arruinando nuestro trabajo.

3.- Using a metal ruler, you can cut precisely and without worrying about breaking the tool.
3.- Usando una regla de metal, puede cortar con precisión y sin preocuparse por romper la herramienta.

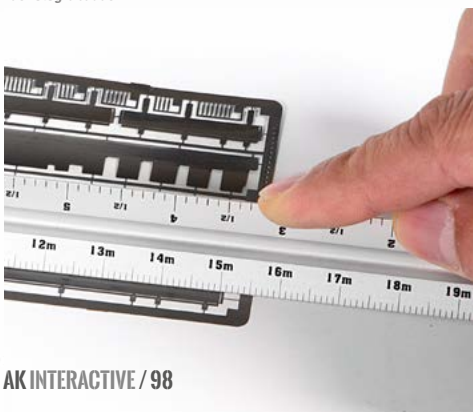

9.4 MASKING TAPE / CINTA DE ENMASCARAR

High quality rice paper tape to mask, protect, and delimit areas during the painting processes, or to temporarily fix some parts together. Its special glue does not leave any kind of residue and is ultra-smooth to prevent damage or lifting the paint layer. Has a matt surgance to better absorption of the the paint and avoid slip.

Cinta de papel de arroz de alta calidad para enmascarar, proteger y delimitar áreas durante los procesos de pintura, o para arreglar temporalmente algunas partes. Su pegamento especial no deja ningún tipo de residuo y es ultra suave para evitar daños o levantar la capa de pintura. Es mate para absorber mejor la pintura y que no resbale.

AK8210 MASKING TAPE A4 SIZE



AK8201
MASKING TAPE: 2MM



AK8202
MASKING TAPE: 3MM



AK8203
MASKING TAPE: 5MM



AK8204
MASKING TAPE: 12MM



AK8205
MASKING TAPE: 18MM

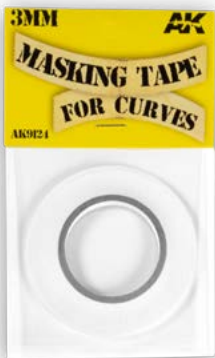

AK9124
MASKING TAPE FOR CURVES
3 MM. 18 meters long.



AK9125
MASKING TAPE FOR CURVES
6 MM. 18 meters long.



AK9126
MASKING TAPE FOR CURVES
10 MM. 18 meters long.

3 mm, 6mm and 10mm masking tape for curves. Perfect grip without residue. The tape is made from a soft resin material, allowing the tape to adhere in a curved line while preventing paint from slipping into masked off areas.

This tape allows you to make curves of any shape or pattern that you need. This product will work well for canopy masking, painting spirals and complex camouflage patterns.

Cinta de enmascarar de 3 mm, 6mm y 10mm para curvas. Agarre perfecto sin residuos. La cinta está hecha con un material de resina suave, lo que permite que se adhiera y se puedan realizar líneas curvas evitando que la pintura se filtre en las zonas enmascaradas. Esta cinta le permite hacer curvas de cualquier forma o patrón que necesite. Este producto es ideal para enmascarar cabinas, realizar espirales y patrones de camuflajes.

MASKING TAPE FOR CURVES CINTA DE ENMASCARAR PARA CURVAS



9.5 SANDPAPER / PAPEL DE LIJA



AK9073
WET SANDPAPER
600 GRIT. 3 UNITS



AK9032
WET SANDPAPER
800 GRIT. 3 UNITS



AK9033
WET SANDPAPER
1000 GRIT. 3 UNITS

WET SANDPAPER

High quality sandpaper with resistant minerals and impregnated with a water resistant substance for wet sanding hand-works. Special to smooth and perform polishing works combining different numbers from the thickest to the finest. Moisten the sandpaper with water and work on a wet surface. Sanding in wet prevents the surface from getting rough, obtaining optimal results. We recommend starting with a thick grain (lower numbers) and end up with a fine grain (higher numbers) for a perfect sanding / polishing of your miniatures.

Lija de papel de alta calidad con minerales resistentes e impregnada con una sustancia resistente al agua para el lijado a mano en húmedo.

Especiales para alisar y para realizar trabajos de pulido combinando distintas numeraciones desde la más gruesa hasta la más fina.

Moja la lija con agua y trabaja en una superficie húmeda. El lijado en húmedo evita que la superficies se emboce consiguiendo óptimos resultados.

Recomendamos empezar por un grano grueso (números más bajos) y acabar por un grano más fino (números más altos) para un perfecto lijado/pulido de tus miniaturas.



AK9034
WET SANDPAPER
1200 GRIT. 3 UNITS



AK9035
WET SANDPAPER
1500 GRIT. 3 UNITS



AK9036
WET SANDPAPER
2000 GRIT. 3 UNITS



AK9037
WET SANDPAPER
2500 GRIT. 3 UNITS

DRY SANDPAPER

High quality sandpaper with resistant minerals for dry hand sanding. Special for smoothing and performing combined polishing works different numbers from the thickest to the finest. Paper is a flexible material with very good resistance. We recommend starting with a thick grain (lower numbers) and ending with a fine grain (higher numbers) for a perfect sanding / polishing of your miniatures.

Lija de papel de alta calidad con minerales resistentes para el lijado a mano en seco. Especiales para alisar y para realizar trabajos de pulido combinando distintas numeraciones, desde la más gruesa hasta la más fina. El papel es un material flexible con muy buena resistencia. Recomendamos empezar por un grano grueso (números más bajos) y acabar por un grano más fino (números más altos) para un perfecto lijado/pulido de tus miniaturas.



AK9038
DRY SANDPAPER
400 GRIT. 3 UNITS



AK9039
DRY SANDPAPER
600 GRIT. 3 UNITS



AK9041
DRY SANDPAPER
800 GRIT. 3 UNITS



AK9042
DRY SANDPAPER
1000 GRIT. 3 UNITS

WET



AK9028

AK9027

AK9026

SANDPAPER

Choose the suitable sandpaper for your work (water or dry based) and thanks to these practical strips of different grains and measures 11x1 cm. you could reach difficult areas comfortably, and discard them when they have worn out. 50 strips included per set.

Escoge la lija precisa para tu trabajo (al agua o en seco) y gracias a estas prácticas tiras de distintos granos y de medidas 11x1 cm. podrás llegar a zonas difíciles cómodamente y desecharlas cuando se hayan desgastado. Incluye 50 tiras por set.



DRY



AK9025

AK9024

AK9023

AK9022

AK9029

DOBLE-SIDED SPONGE FILE
TWO SIDES, DIFFERENT RESULTS:
SEMI-GLOSS EFFECT / FINE
POLISHING

Practical sanding sponges, triangular finishing, to reach the most difficult corners. Its two faces have a different grain for the most demanding finishes. Semi-gloss and polished effect.

Prácticas esponjas de lija con acabado triangular, para llegar a los rincones más difíciles.

Sus dos caras tienen un grano diferente para los acabados más exigentes. Efecto semi brillo y pulido.



AK9016
COARSE SANDING PADS
120 GRIT. 4 UNITS.

A super flexible high quality sanding sponge. Resists jamming. Folds and adapts without breaking for comfortable sanding. The colour of the sponge identifies the grit size.

Red: 120

Una esponja de lijado súper flexible de alta calidad. Resiste atascos. Se pliega y se adapta sin romperse para un lijado cómodo. El color de la esponja identifica el tamaño de grano. Rojo: 120



AK9017
MEDIUM SANDING PADS
220 GRIT. 4 UNITS.

A super flexible high quality sanding sponge. Resists jamming. Folds and adapts without breaking for comfortable sanding. The colour of the sponge identifies the grit size.

Yellow: 220

Una esponja de lijado súper flexible de alta calidad. Resiste atascos. Se pliega y se adapta sin romperse para un lijado cómodo. El color de la esponja identifica el tamaño de grano. Amarillo: 220



AK9019
SUPER FINE SANDING PADS
800 GRIT. 4 UNITS.

A super flexible high quality sanding sponge. Resists jamming. Folds and adapts without breaking for comfortable sanding. The colour of the sponge identifies the grit size.

Green: 800

Una esponja de lijado súper flexible de alta calidad. Resiste atascos. Se pliega y se adapta sin romperse para un lijado cómodo. El color de la esponja identifica el tamaño de grano. Verde: 800



AK9021
MIXED GRIT SANDING PADS
SET. 4 UNITS.

This set contains one unit of each of the super flexible, jam resistant sponges. They fold and adapt without breaking for very comfortable sanding. The colour of the sponge identifies the grit size.

Grit sizes included: 800, 400, 220, 120. Este set contiene una unidad de cada tipo de lija en esponja súper flexible y resistente a los atascos. Se pliegan y se adaptan sin romperse para un lijado muy cómodo. El color de la esponja identifica el tamaño de grano.

Tamaños de grano incluidos: 800, 400, 220, 120



AK9018
FINE SANDING PADS
400 GRIT. 4 UNITS.

A super flexible high quality sanding sponge. Resists jamming. Folds and adapts without breaking for comfortable sanding. The colour of the sponge identifies the grit size.

Blue: 400

Una esponja de lijado súper flexible de alta calidad. Resiste atascos. Se pliega y se adapta sin romperse para un lijado cómodo. El color de la esponja identifica el tamaño de grano. Azul: 400

9.6 BRASS PIPES / TUBOS DE LATON

Modeling pipes made from High Quality brass. 20cm rods. Ideal for the creation of specific details in model kits, architecture works and scenes. Can be fixed with cyanoacrylate glues, two component adhesives or by welding.

Tubos de modelado de latón de alta calidad. Varillas de 20cm. Ideal para la creación de detalles específicos en maquetas, obras de arquitectura y escenas. Se puede fijar con pegamentos de cianoacrilato, adhesivos de dos componentes o mediante soldadura.

AK9101
BRASS PIPES
0.2MM Ø. 2 UNITS.



AK9102
BRASS PIPES
0.3MM Ø. 5 UNITS.



AK9103
BRASS PIPES
0.4MM Ø. 5 UNITS.



AK9104
BRASS PIPES
0.5MM Ø. 5 UNITS.



AK9105
BRASS PIPES
0.6MM Ø. 5 UNITS.



AK9106
BRASS PIPES
0.7MM Ø. 5 UNITS.



AK9107
BRASS PIPES
0.8MM Ø. 5 UNITS.



AK9108
BRASS PIPES
0.9MM Ø. 5 UNITS.



AK9109
BRASS PIPES
1MM Ø. 5 UNITS.



AK9110
BRASS PIPES
1.1MM Ø. 5 UNITS.



AK9111
BRASS PIPES
1.2MM Ø. 5 UNITS.



AK9112
BRASS PIPES
1.3MM Ø. 5 UNITS.



AK9113
BRASS PIPES
1.4MM Ø. 5 UNITS.

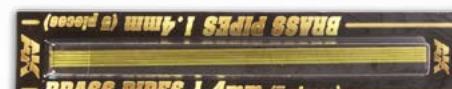

AK9114
BRASS PIPES
1.5MM Ø. 5 UNITS.



AK9115
BRASS PIPES
1.6MM Ø. 5 UNITS.

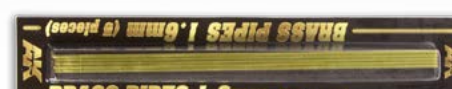

AK9116
BRASS PIPES
1.7MM Ø. 5 UNITS.



AK9117
BRASS PIPES
1.8MM Ø. 5 UNITS.



AK9118
BRASS PIPES
2.0MM Ø. 2 UNITS.



AK9119
BRASS PIPES
2.2MM Ø. 2 UNITS.

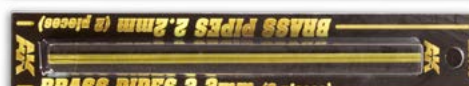

AK9120
BRASS PIPES
2.4MM Ø. 2 UNITS.



AK9121
BRASS PIPES
2.6MM Ø. 2 UNITS.

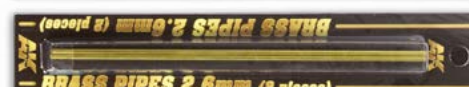

AK9122
BRASS PIPES
2.8MM Ø. 2 UNITS.



AK9123
BRASS PIPES
3.0MM Ø. 2 UNITS.

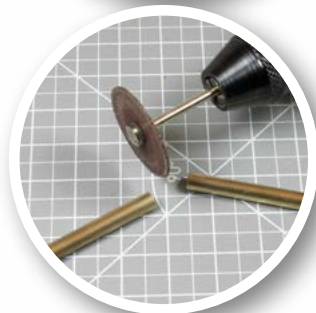
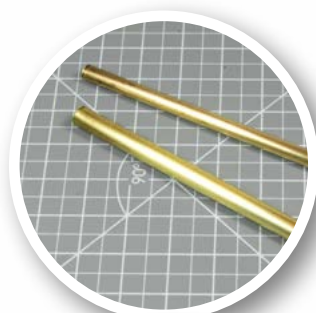
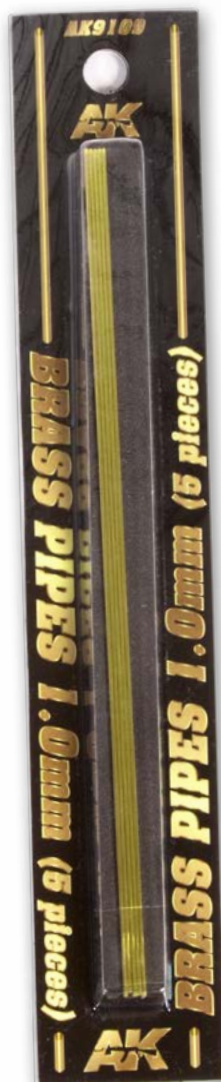
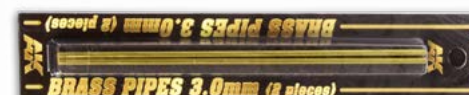

AK Airbrush 0.3 BASIC LINE

ART *loves* TECHNOLOGY



Simple to assemble, great performance and versatile use.

Easy to clean and made for precision and fine painting. Permanent stock will be available in case spare parts are needed.

Unleash your creativity with this new tool that will bring your models to the next level!

WWW.AK-INTERACTIVE.COM

AK INTERACTIVE / 103



AK9000 AK AIRBRUSH BASIC LINE 0.3

A new basic airbrush that will allow the modeler to perform detail work with ease and maximum precision. Thanks to its 0.3mm nozzle and needle you can spray the paint with total control. Our airbrush is easy to clean and maintain. The basic line airbrush is perfect for beginners and all modelers who want a strong airbrush that offers good performance at an economical price.

It is presented in an attractive box which includes a cleaning tool, a wrench to disassemble the nozzle and two different tip pieces.

Double action airbrush / gravity feed.

0.3mm nozzle.

Adjustable stop for needle recoil.

Components made of resistant and strong materials.

1/8 air hose connection.

Un nuevo aerógrafo básico que permitirá al modelista realizar trabajos de máxima precisión con facilidad. Gracias a su boquilla y aguja de 0,3mm se pueden realizar trazos finos con un control total y resulta muy cómodo de limpiar y con un mantenimiento muy sencillo. La línea básica es ideal para principiantes y para todo tipo de modelistas que quieren un aerógrafo robusto con buenas prestaciones a un precio económico.

Viene presentado en una atractiva caja que incluye una herramienta de limpieza, una llave para desmontar la boquilla y dos piezas para la punta distintas. Aerógrafo de doble acción y alimentación por gravedad.

Boquilla de salida de 0,3mm.

Tope ajustable para el retroceso de la aguja.

Componentes fabricados con materiales fuertes y resistentes.

Conectores de manguera de 1/8.





AK9001
0.3 NEEDLE
AIRBRUSH BASIC LINE 0.3

Replacement needle 0.3mm for the airbrush AK basic line (AK9000)
Aguja de repuesto de 0.3 para el aerógrafo línea básica de AK. (AK9000)



AK9002
0.3 NOZZLE
AIRBRUSH BASIC LINE 0.3

Replacement nozzle 0.3mm for the airbrush AK basic line (AK9000).
Recambio de boquilla 0.3 para el aerógrafo línea básica de AK. (AK9000).



AK9003
HOSE (3 METROS)
AIRBRUSH BASIC LINE 0.3

High strength airbrush hose made of outer braided nylon, soft and durable. With 1/8" BSP female connectors on both ends.
3 meters long.

Manguera para aerógrafos de alta resistencia de nailon trenzado exterior, suave y duradero. Con conectores hembra BSP de 1/8" en ambos extremos. 3 metros de longitud.



AK9004
RUBBER RINGS (20 UNIDADES)
AIRBRUSH BASIC LINE 0.3

Set with 20 units of rubber toric joints. The Basic Line series airbrush (AK9000) uses this type of rubber gaskets but also many other types of airbrushes use similar gaskets.
Set con 20 unidades de juntas tóricas de goma. El aerógrafo de la serie Basic Line utiliza este tipo de juntas de goma pero también muchos otros tipos de aerógrafos utilizan juntas similares.



AK9045
AIRBRUSH MASKING FILM

High quality airbrush paper. Special for modeling. Transparent PVC film with acrylic adhesive. Low adherence, zero residue, especially for masking scale models, works really good over glossy or matt surface.

Plantilla de PVC transparente con adhesivo acrílico, baja adherencia, cero residuos, especialmente para enmascarar maquetas a escala, funciona muy bien sobre una superficie brillante o mate.



AK9079
FLEXIBLE AIRBRUSH STENCIL
1/20 - 1/24 - 1/35

AK9080
FLEXIBLE AIRBRUSH STENCIL
1/48 - 1/72

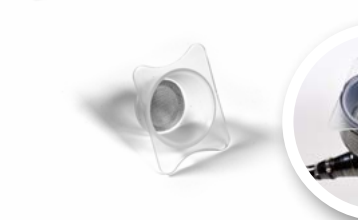

AK9053
AIRBRUSH HOLDER

Airbrush holder, can hold up to two airbrushes. You can adapt in height and angle the holder for a more comfortable working position. Suitable for most of the workbenches. Suitable for most airbrushes. Plastic cover protection all over the upper support to avoid damages in the airbrush. Long life product. Use this tool while filling up your airbrush with paint. Make your hobby easier, use tools for working better.
Soporte para aerógrafo, puede contener hasta dos aerógrafos. Puede adaptar la altura y el ángulo del soporte para una posición de trabajo más cómoda. Adecuado para la mayoría de los bancos de trabajo. Apto para la mayoría de los aerógrafos. Protección de la cubierta de plástico en todo el soporte superior para evitar daños en el aerógrafo. Producto de larga vida. Use esta herramienta mientras llena su aerógrafo con pintura. Haz tu hobby más fácil, usa herramientas para trabajar mejor.



AK9129
AIRBRUSH PURIFICATION CUP

Special accessory for a better paint process and care for the airbrush.
* Filter your paints while pouring them into the airbrush cup.
* Avoid problems by removing lumps that can cause clogging.
* Diameter of 21mm. Compatible with standard cups.
* Can be used for acrylics, lacquers and any type of paint.
* A simple and effective tool.

Accesorio especial para un mejor proceso de pintura y cuidado del aerógrafo.

* Filtre sus pinturas mientras las introduce en el depósito del aerógrafo.
* Evite problemas al obtener su pintura sin grumos que pueden causar obstrucción.
* Diámetro de 21mm. Compatible con copas standard.
* Se puede usar para acrílicos, lacas y cualquier tipo de pintura.
* Una herramienta simple y efectiva.





AK8076 CAMOUFLAGE ELASTIC PUTTY 80 gr.



Reusable putty for masking areas when airbrushing. Specially designed to leave no residue on any surface. Can be easily removed without damaging other painted areas. Doesn't stain and is grease-free. The best quality with the best price in a product that is perfect for modelers. This putty can adapt to any surface and allows for the creation of both camouflage and general masking of areas (such as wheels or clear parts) that don't need to be painted.

Masilla reutilizable para enmascarar zonas al aerografiar. Especialmente diseñado para no dejar residuos en ninguna superficie. Se puede quitar fácilmente sin dañar otras áreas pintadas. No mancha y está libre de grasa. La mejor calidad a un precio excelente en un producto perfecto para los modelistas que se pueden adaptar a cualquier superficie y que permite realizar camuflajes y enmascarar áreas (como ruedas o piezas transparentes) que no se quieren pintar.



1

Place the masking putty around the areas you want to keep unpainted. Remember to use masking tape in areas such as windows.

Coloque la masilla de enmascaramiento alrededor de las áreas que desea mantener sin pintar. Recuerde usar cinta adhesiva en áreas como las ventanas.



2

Its elastic consistency makes it very easy to apply. Take real photo references to match the desired camouflage.

Su consistencia elástica hace que sea muy fácil de aplicar. Tome referencias reales de fotos para que coincida con el camuflaje deseado.



3

Using an airbrush, apply the first camouflage color.

Usando el aerógrafo, pinte cómodamente la pieza para el primer color de camuflaje.



4

Remove the masking putty and observe the results.

Retire la masilla de enmascaramiento y observe los buenos resultados.



5

Again, place the masking putty over the desired areas and in readiness for the second camouflage color.

De nuevo, coloque la masilla de enmascaramiento sobre las áreas deseadas para aplicar el segundo color de camuflaje.



6

Apply the second color as you did before.

Aplicar el segundo color como hicimos antes.



7

The result is a perfectly fine camouflage, and the masking putty can be cleaned and stored for the next use.

El resultado es un camuflaje fino perfecto y la masilla de enmascaramiento se puede limpiar y almacenar para el siguiente uso.





AK8064 WET PALETTE

The Wet Palette is a tool mainly used by figure painters but is more and more being used by people who paint with acrylics. It will extend the useful life of any acrylic so that it can be used for hours after leaving the bottle, and once shut it will preserve the colors and color mixtures. It can be kept in the fridge.

It has three components:

1. Sponge, to hold large quantities of water, since it is quite thick.
2. Cloth made of fiber, placed on top of the sponge as a leveler, humidity filter, and as an interchangeable element in case of stains, or if not used for a long time.
3. High quality Special Paper, made of a fine silicone film, allows the transfer of humidity but prevents water forming and paints from dissolving, and does not shed any fibers when worked with brushes.

The Wet Palette is watertight and airtight, made of the same material as marine containers for flares, charts, and medicines. Its locks guarantee the seal. This extends the life of paints, especially in summer, hot climates, and under extreme conditions.

La Wet Palette es una herramienta utilizada principalmente por pintores de figuras, pero cada vez más es utilizada por personas que pintan con acrílicos. Extenderá la vida útil de cualquier acrílico para que pueda usarse durante horas y una vez que se cierre, conservará los colores y las mezclas de colores. Se puede guardar en la nevera.

1. Esponja, para contener grandes cantidades de agua, ya que es bastante espesa.

2. Tela hecha de fibra, colocada sobre la esponja como nivelador, filtro de humedad y como elemento intercambiable en caso de manchas o si no se utiliza durante mucho tiempo.

3. El papel especial de alta calidad, hecho de una película de silicona fina, permite la transferencia de humedad pero evita que se forme agua y que las pinturas se disuelvan, y no desprende fibras ni pelos cuando se trabaja con los pinceles.

La Wet Palette es impermeable y hermética, y está hecha del mismo material de contenedores marinos para bengalas, tablas y medicamentos. Sus cerraduras garantizan el sellado. Esto prolonga la vida útil de las pinturas, especialmente en verano, climas cálidos y en condiciones extremas.

Content / Contenido:
1 AK Wet Palette / AK Paleta Húmeda
1 Wipe / Tela
40 Papers / Papeles
2 Foams / Esponjas

Spare / Repuestos:



AK8073
WIPE / TELA



AK8074
PAPER 40 UNITS / PAPEL 40 UNIDADES



AK8075
FOAM / ESPONJA

The spare parts for the components of the Wet Palette will remain available, in the correct sizes and ready to be used. The top and bottom of the palette can be used as workable areas if so desired. The spares also fit on both parts.

The size of the Wet Palette is designed to offer the largest possible working area while taking as little space as possible on the working desk.

It is stable also when in motion.

Siempre habrá repuestos disponibles para los componentes de la Wet Palette, y el tamaño correcto, listos para ser utilizados.

La parte superior e inferior de la paleta se pueden utilizar como áreas de trabajo si así se desea. Las piezas de repuesto también caben en ambas partes.

El tamaño de la Wet Palette está concebido para ofrecer la mayor área de trabajo posible, al tiempo que ocupa el mínimo espacio posible en la mesa de trabajo.

Es estable también cuando está en movimiento.



Introduce the sponge in the palette and try to make sure it has a good amount of water left.

Introduzca la esponja en la paleta y trate de asegurarse de que le quede una buena cantidad de agua.

Soak the sponge with tap or distilled water, depending on which one you use.

Empape la esponja con agua del grifo o destilada, dependiendo de cuál use.

Wet the wipe with water until it is completely saturated. And place it over the foam.

Moje la toallita con agua hasta que esté completamente saturada y colóquela sobre la espuma.



Moisten the paper with care. Place the paper, centered over the wipe, to cover it.
Humedezca el papel con cuidado. Coloque el papel centrado sobre el paño para cubrirlo.

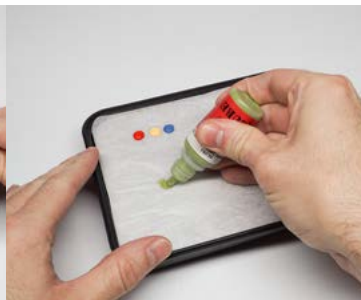

Place the paints you are going to mix, considering the space you have.
Coloque las pinturas que vas a mezclar, considerando el espacio que tienes.



Mix the paints as needed, and when finished, leave it in the fridge for further use.
Mezcle las pinturas según sus necesidades y, cuando termine, déjelas en el refrigerador para seguir usándolas.



9.8 BRUSHES / PINCELES

Our high quality synthetic brushes come in a wide array of sizes and shapes. This includes special brushes that are specifically developed to help you in weathering your models.

Nuestros pinceles sintéticos de alta calidad se presentan en una amplia gama de tamaños y formas. Esto incluye pinceles especiales que están específicamente desarrollados para ayudarte a envejecer tus modelos.

9.8.1 SYNTHETIC BRUSHES / PINCELES SINTÉTICOS



9.8.2 SPECIAL SYNTHETIC BRUSHES FOR WEATHERING / PINCELES SINTÉTICOS ESPECIALES PARA EL ENVEJECIMIENTO



AK663
Included / Incluye:
AK576, AK577, AK578,
AK579, AK580



9.8.3 PREMIUM SIBERIAN KOLINSKY BRUSHES / PINCELES PREMIUM SIBERIAN KOLINSKY

These premium brushes made by hand by expert craftsmen are made with the best Kolinsky Siberian hair and are some of the highest quality brushes on the market. The softness of the hair and the load-bearing capacity are ideal for figure painters looking for an extreme quality brush with a great capacity to line.

Natural brushes require more care than synthetic hair brushes, as their deterioration leads to loss of shape and degradation of the hair. To increase their service, good maintenance and cleaning is recommended so that paint residues do not dry on your hair. Recommended for any type of acrylic paint.

Estos pinceles elaborados a mano por expertos artesanos están realizados con los mejores pelos de Kolinsky Siberiana y son unos de los pinceles de más alta calidad en el mercado. La suavidad del pelo y la capacidad de carga son ideales para los pintores de figuras que buscan un pincel de extrema calidad con gran capacidad de trazo.

Se presentan en un tubo transparente y están disponibles en cuatro tamaños.

Los pinceles naturales exigen más cuidado que los pinceles de pelo sintético, ya que su deterioro conduce a la pérdida de la forma y degradación del pelo. Para aumentar su vida útil, es recomendable un buen mantenimiento y limpieza para que no se sequen restos de pintura en sus pelos. Recomendados para cualquier tipo de pintura acrílica.

AKSK-2/0

SIBERIAN KOLINSKY BRUSH



AKSK-0

SIBERIAN KOLINSKY BRUSH

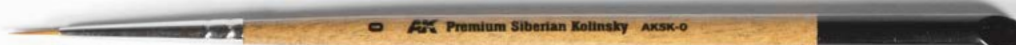

AKSK-1

SIBERIAN KOLINSKY BRUSH

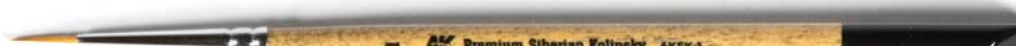

AKSK-2

SIBERIAN KOLINSKY BRUSH



AKSK-10

SIBERIAN KOLINSKY BRUSHES DELUXE CASE

Premium AK Siberian Kolinsky 4 Brush Case: Sizes: 00-0-1-2

These sizes correspond to the brushes most demanded by figure painters of any scale.

Estuche con cuatro pinceles Siberian Kolinsky de AK: Numeraciones: 00-0-1-2

Estos números corresponden a los pinceles más demandados por los pintores de figuras de cualquier escala.



9.8.4 DRY BRUSH / PINCEL SECO

AK621

DRY BRUSH

AK Premium synthetic hair brush, special for the dry brush technique.

This short hair brush is designed to apply the dry brush technique on different scenes, warhammer bases or any other piece.

Pincel AK Premium de pelo sintético, especial para la técnica de pincel seco.

Este pincel de pelo corto está diseñado para aplicar la técnica de pincel seco sobre diferentes escenas, bases warhammer o cualquier otra pieza.



9.9 ACCESSORIES / ACCESORIOS

9.9.1 LENSES & TOW CHAINS / LENTES Y CADENAS

Ready to use accessories which will add more realism to your model. Just remove them from their packaging and install on your miniature. Forget about complicated finishing processes you've applied in the past to reproduce the lenses or tow chains.

Accesorios listos para usar que aportarán más realismo a tu modelo. Solo retíralos de su soporte y colócalos en tu miniatura. Olvidate de los complicados procesos de acabado que aplicaste en el pasado para reproducir las lentes o las cadenas a escala.



AK200
WHITE 1MM



AK201
RED 1MM



AK202
AMBER 1MM



AK203
WHITE 1.5MM



AK204
RED 1.5MM



AK205
AMBER 1.5MM



AK206
WHITE 2MM



AK207
RED 2MM



AK208
AMBER 2MM



AK210
RED 2.3MM



AK211
AMBER 2.3MM



AK212
WHITE 3MM



AK213
RED 3MM



AK214
AMBER 3MM



AK216
RED 4MM



AK217
AMBER 4MM



AK218
WHITE 5MM



AK219
RED 5MM



AK220
AMBER 5MM



AK221
WHITE & BLACK 3MM



AK222
OPTIC COLOR 1MM



AK223
OPTIC COLOR 1.5MM



AK224
OPTIC COLOR 2MM



AK225
OPTIC COLOR 2.3MM



AK226
OPTIC COLOR 3MM



AK227
OPTIC COLOR 4MM



AK228
OPTIC COLOR 5MM



AK232
LIGHTS FOR
AIRCRAFT 1MM



AK233
LIGHTS FOR
AIRCRAFT 1.5MM



AK235
LIGHTS FOR
AIRCRAFT 2.3MM



AK237
WHITE LENSES 2.7MM



AK229
RUSTY TOW CHAIN
SMALL

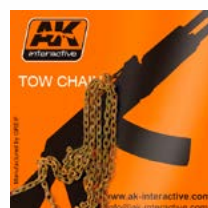

AK230
RUSTY TOW CHAIN
MEDIUM



AK231
RUSTY TOW CHAIN
BIG

9.9.2 CAMOUFLAGE NETS / REDES DE CAMUFLAJE

Modern camouflage nets for your 1/35 scale vehicles. They can be applied directly or further decorated with acrylics, lacquers or enamels to achieve a realistic camouflage effect depending on the situation and environment chosen for your model.

Redes de camuflaje modernas para tus vehículos de escala 1/35. Se pueden colocar directamente o pintadas con acrílicos, lacas o esmaltes para lograr un efecto de camuflaje realista según la situación y el entorno elegidos para tu modelo.



AK8060
CAMOUFLAGE NET SAND
TYPE 1

AK8061
CAMOUFLAGE NET
PERSONALIZED WHITE
TYPE 1

AK8062
CAMOUFLAGE NET
BROWN TYPE 2

AK8063
CAMOUFLAGE NET
PERSONALIZED WHITE
TYPE 2

AK8066
CAMOUFLAGE NET FIELD
GREEN TYPE 1

AK8067
CAMOUFLAGE NET FIELD
GREEN TYPE 2

9.9.3 BOBBIN / BOBINAS

The elastic thread is a suitable material in modeling to make any type of ultra-realistic bracing in airplanes, boats, antenna fastening, Sci-fi, dioramas, etc. Elasticity allows for easy installation and a natural fit tight. It can be glued with cyanoacrylate, handled with tweezers. The excess may be cut with a sharp blade. Once placed it can be easily painted with an ink marker or silver paint if desired. It is provided as a practical spool and is 20m long.

El hilo elástico es un material adecuado en modelismo para realizar cualquier tipo de riostrado ultra-realista en aviones, barcos, sujeción de antenas, Sci-fi, dioramas etc. La elasticidad permite colocarse fácilmente y ajustarse de forma natural tensada. Se puede pegar con cianocrilato, manejar con una pinza y cortar el sobrante con una cuchilla afilada. Una vez colocado es muy sencillo de pintar con un marcador de tinta o pintura plateada si se desea. Se sirve en una práctica bobina y tiene 20m de longitud.



AK9134
BOBBIN MEGA-THIN

SUITABLE FOR 1/700 AND LESS
SCALE SHIP ANTENNAS.

AK91345
BOBBIN HYPER-THIN

SUITABLE FOR 1/72 RIGGING. 1/350 - 1/700
SHIP ANTENNAS.

AK9136
BOBBIN SUPER-THIN

SUITABLE FOR 1/35 - 1/32 - 1/48 THIN
RIGGING, ANTENNAS AND WIRES. 1/350 SHIP
ANTENNAS.

AK9137
BOBBIN THIN

SUITABLE FOR 1/35 - 1/32 - 1/48
RIGGING.

9.9.4 MAGNETS / IMANES

Use the magnets to assemble your constructions, for fixing the models to the base, for creating interchangeable pieces and much more multiple uses.

Use los imanes para ensamblar sus construcciones, para fijar los modelos a la base, para crear piezas intercambiables y muchos más usos múltiples.



AK9130
IMANES DE NEODIMIO
3X1 MM N35



AK9131
IMANES DE NEODIMIO
3X2 MM N35



AK9132
IMANES DE NEODIMIO
3X1 MM N52



AK9133
IMANES DE NEODIMIO
3X2 MM N52

9.9.5 DECALS / CALCAS

Set of decals printed in the most high quality by Cartograf simulating a fine wood grain planking texture and some popular graffitiies. Can be used from 1/32 to 1/48. The product can match different applications from railway vehicles to aircrafts, floors, boxes, accessories , etc.

Set de calcas impreso en la más alta calidad por Cartograf simulando una textura de tablaje de grano de madera fina y algunos graffitis populares. Se puede usar de 1/32 a 1/48. El producto puede adaptarse a diferentes aplicaciones, desde vehiculos ferroviarios hasta aviones, suelos, cajas, accesorios, etc.



AK9081
LIGHT WOOD DECALS



AK9082
WOOD VEINS DECALS



AK9084
WOOD DECALS



AK9091
ASSORTED GRAFFITI DECALS



AK801
NATIONALIST T-26
TANKS IN THE SPANISH
CIVIL WAR



AK803
RUSSIAN NAVAL
INFANTRY



AK804
CHECHNYA WAR IN
RUSSIAN TANKS AND
AFVS



AK805
WAR IN AFGHANISTAN
NORTHERN ALLIANCE
TANKS AND AFV



AK806
MODERN RUSSIAN
TANKS AND AFVS



AK807
DANGEROUS GOODS
SIGNS FOR VEHICLES

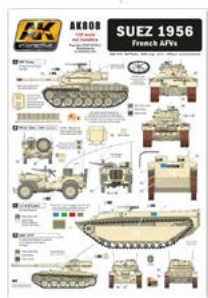

AK808
SUEZ 1956 FRENCH
AFVS



AK809
SOUTH AMERICAN
TANKS AND AFVS
CHILE, PARAGUAY AND
CUBA



AK810
TANKS AND AFVS IN
BOSNIA



AK811
US HALFTRACKS AND
M5A1 IN NORTH AFRICA



AK812
AXIS & EAST EUROPEAN
PZKPFW II, III, IV

MODERN AFV PAINTING TECHNIQUES

464 pages. More than 2.500 images

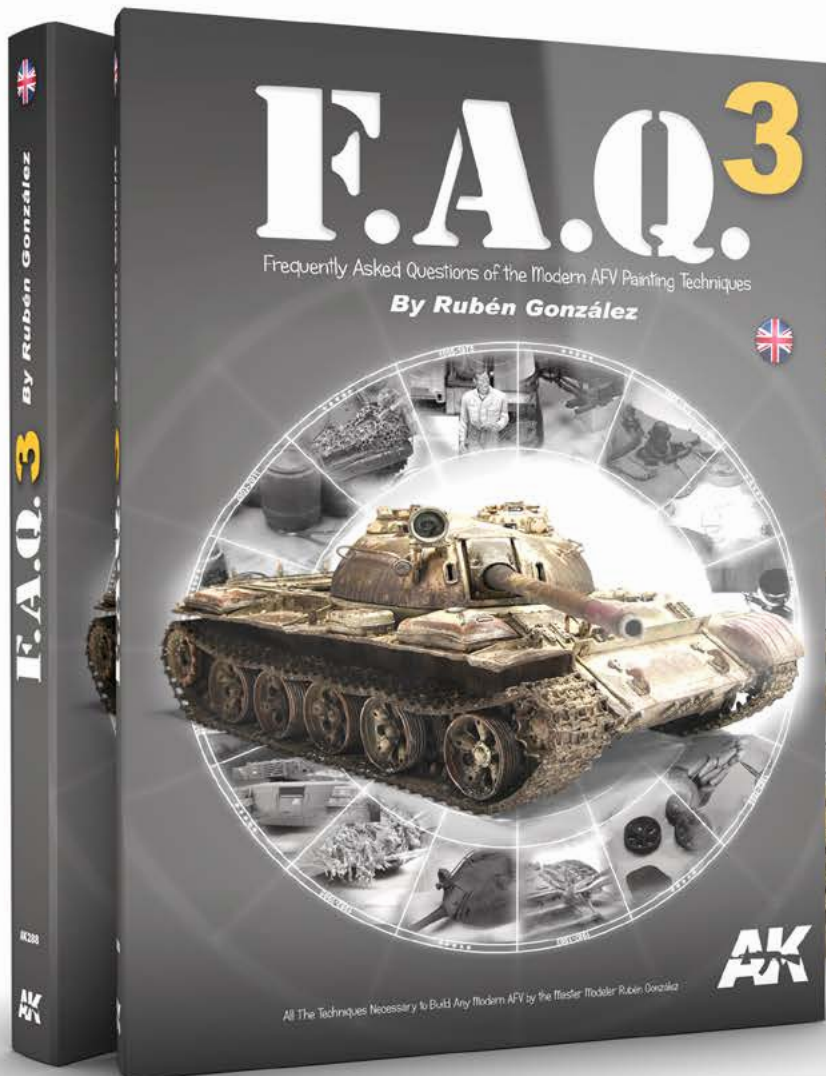

This new Super-Book, like its predecessors in this same series of technical manuals called "FAQ", is dedicated to modeling military vehicles and the techniques used for assembling, painting and weathering. The difference with the previous book is that we have moved on in the timeframe and this book is a complement of the previous ones. It also explains some new techniques that have appeared these last years, mainly to use in modern vehicles but that can be also used in vehicles of all eras. The most complete book for military vehicles edited until now.



www.ak-interactive.com
Phone & Fax: (+34) 941 22 30 64
info@ak-interactive.com



AK INTERACTIVE / 113

10

MEDIA / IMPRESIÓN Y AUDIOVISUALES

10.1 BOOKS / LIBROS

To satisfy the needs of the discerning modelers, AK Interactive publishes various reference and modeling books which both belong to the very best in these genres. We are especially proud of our F.A.Q. series, which comprises the most complete modeling manuals available on the market.
 Para satisfacer las necesidades de los modelistas más exigentes, AK Interactive publica libros de modelismo, históricos y de referencia que se han convertido en algunos de los manuales más prestigiosos del mercado. Estamos especialmente orgullosos de nuestra serie F.A.Q., que comprende los manuales de modelismo más completos que existen.

10.1.1 F.A.Q. / PREGUNTAS FRECUENTES



AK038
F.A.Q. 2 LIMITED EDITION
 304 pages. English edition

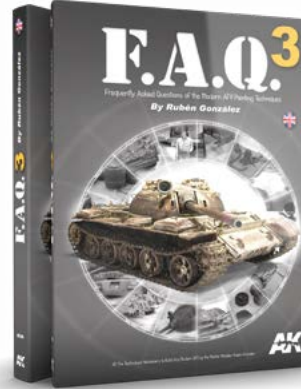

AK288
F.A.Q. 3 MODERN AFVS
 464 pages. English and Spanish editions

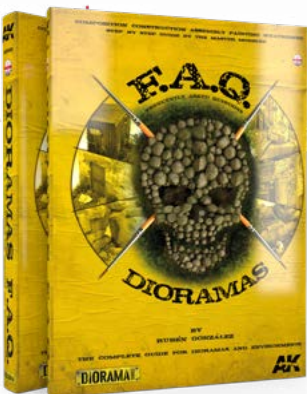

AK8000
DIORAMAS F.A.Q.
 560 pages. English and Spanish editions

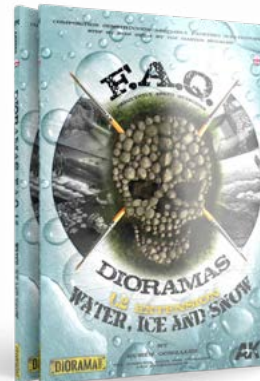
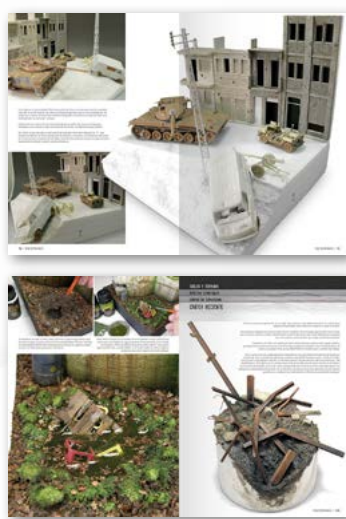

AK8050
DIORAMAS F.A.Q. 1.2 EXTENSION – WATER, ICE & SNOW
 138 pages. English and Spanish editions

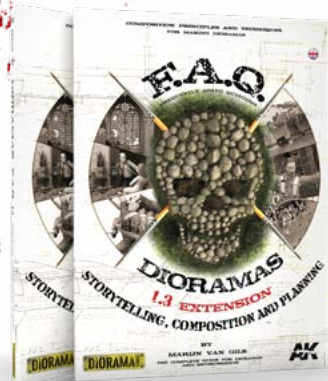

AK8150 / AK8151
DIORAMAS F.A.Q. 1.3 EXTENSION HISTORIA, COMPOSICIÓN Y PLANIFICACIÓN
 240 pages. English and Spanish editions

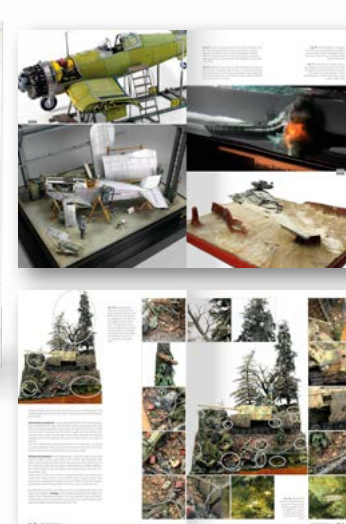

AK276
AIRCRAFT SCALE MODELLING F.A.Q.
 384 pages. English and Spanish editions



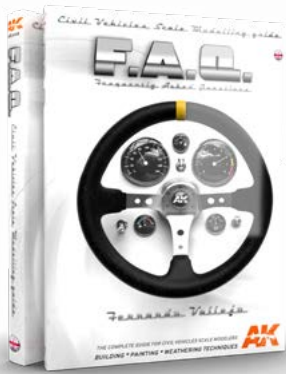

AK282
CIVIL VEHICLES SCALE
MODELLING F.A.Q.
 360 pages. English and Spanish editions



AK631
FIGURES F.A.Q.
FIGURE PAINTING TECHNIQUES
THE COMPLETE GUIDE FOR FIGURE SCALE MODELERS
 488 pages. English and Spanish editions. Semi Hard Cover.



ARE YOU READY TO IMPROVE YOUR PAINTING METHODS AND CHANGE THE FINISH OF YOUR FIGURES FOREVER?

In this book you will find advice and explanation of all techniques and processes which you need to master painting of all types of figures, provided by the best painter of all time: Master Kirill Kanaev.

This guide through the world of figures is a unique book, full of impressive works and examples used to demonstrate the secrets of miniature painting from the basic pillars to the most complex techniques.

Now we put this knowledge in your hands to allow you to become a high level painter.

¿ESTÁS LISTO PARA TRANSFORMAR TUS MÉTODOS DE PINTURA Y CAMBIAR PARA SIEMPRE EL ACABADO DE TUS FIGURAS?

En este libro encontrarás los consejos y las explicaciones para aprender las técnicas y los procesos con los cuales perfeccionar tu pintura de figuras, de la mano del mejor pintor de todos los tiempos: El maestro Kirill Kanaev.

Esta guía, centrada en el mundo de las figuras es un libro único, repleto de trabajos y ejemplos impresionantes que aborda el conocimiento de la pintura de figuras y sus secretos, desde sus pilares básicos hasta las técnicas más complejas.

Ahora está en tus manos ser un pintor de alto nivel.

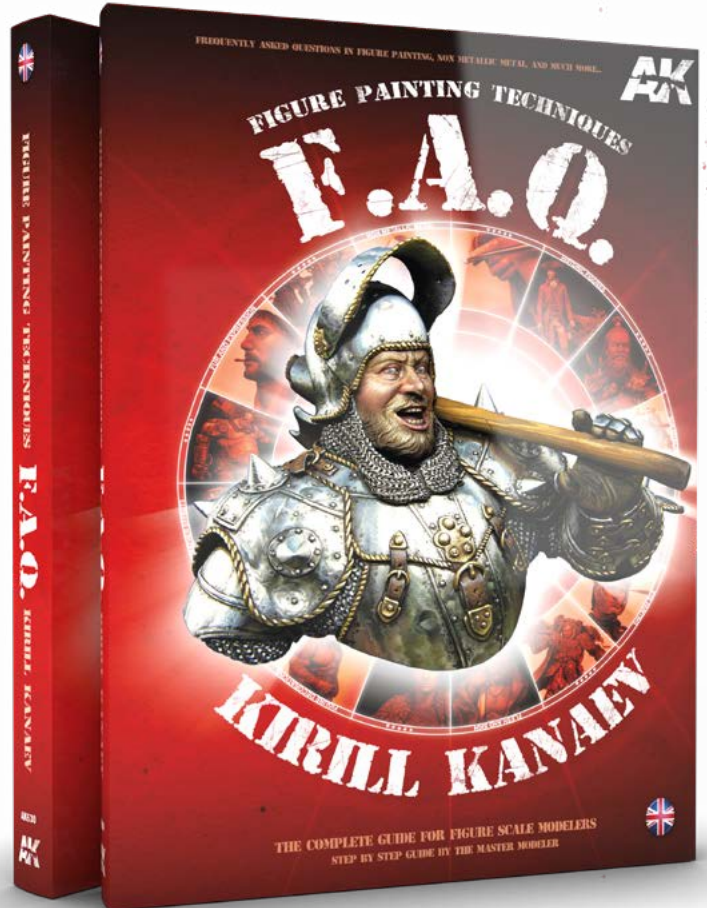

10.1.2 LEARNING SERIES

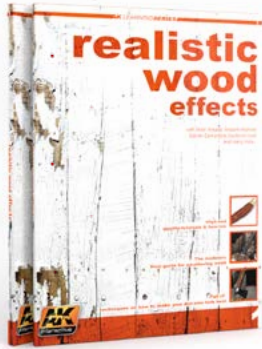

AK259
REALISTIC WOOD EFFECTS.
LEARNING SERIES 1
 86 pages. English edition



AK272
PANZER CREW UNIFORMS PAINTING GUIDE.
LEARNING SERIES 2
 82 pages. English edition



AK274
TRACKS & WHEELS.
LEARNING SERIES 3
 86 pages. English edition

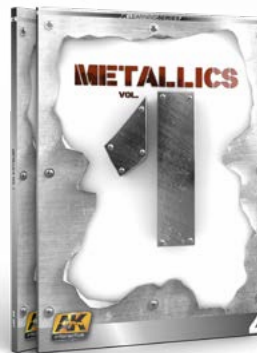

AK507
METALLICS VOL.1. AIRCRAFT & VEHICLES.
LEARNING SERIES 4
 86 pages. English edition

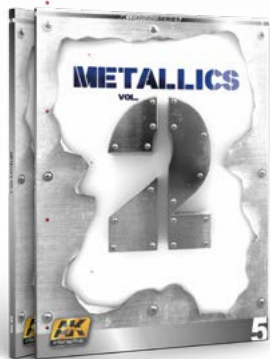

AK508
METALLICS VOL.2. FIGURES.
LEARNING SERIES 5
 92 pages. English edition



AK241
FLESH & SKIN.
LEARNING SERIES 6
 90 pages. English and Spanish editions

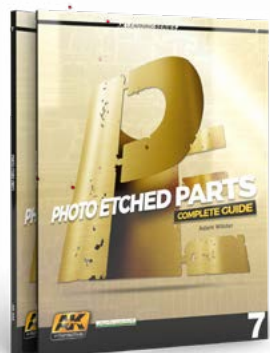
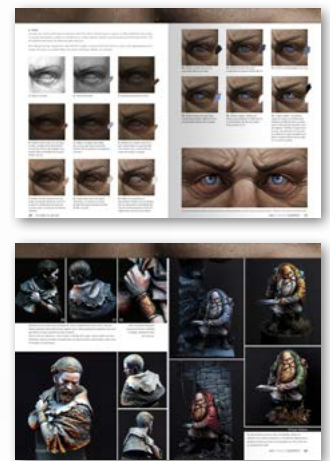

AK244
PHOTOETCHED PARTS.
LEARNING SERIES 7
 90 pages. English and Spanish editions



AK247
MODERN FIGURES CAMOUFLAGES.
LEARNING SERIES 8
 94 pages. English edition

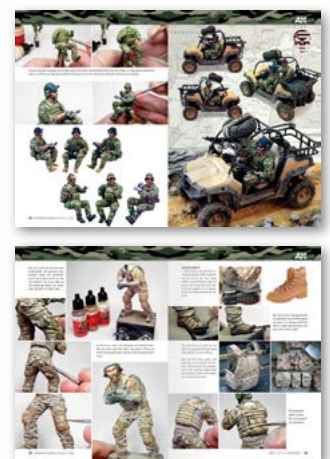

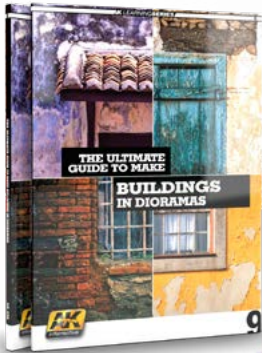

AK256
THE ULTIMATE GUIDE TO MAKE BUILDINGS IN DIORAMAS.
LEARNING SERIES 9
 92 pages. English edition



AK295 / AK296
MASTERING VEGETATION IN MODELING.
AK LEARNING 10
 84 pages. English and Spanish editions

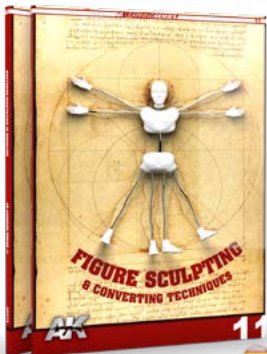

AK512 / AK513
FIGURE SCULPTING & CONVERTING TECHNIQUES.
AK LEARNING 11
 80 pages. English and Spanish editions

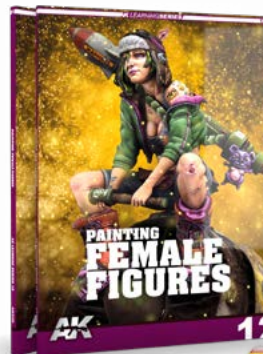
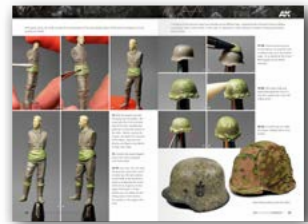

AK520
PAINTING FEMALE FIGURES.
AK LEARNING 12
 100 pages. English and Spanish editions



LEARNING SERIES



10.1.3 MODELING BOOKS / LIBROS DE MODELISMO

Are you a beginner modeler or an advanced one? It does not really matter if youtube tutorials are not your thing because you love the smell of a brand new book edited and printed with weathering passion. Great modelers bringing you great pictures, techniques, tips, products and models to help you enhancing your modeling projects.

¿Eres un modelista principiante o avanzado? Realmente no importa si los tutoriales de Youtube no son lo tuyo porque te encanta el olor de un nuevo libro editado e impreso con pasión. Grandes modelistas que te traen grandes imágenes, técnicas, consejos, productos y modelos para ayudarte a mejorar con sus proyectos de modelado.



AK912 / AK913
DAK. GERMAN AFV IN NORTH AFRICA
196 pages. English and Spanish editions

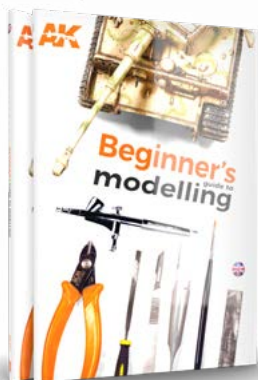

AK251
BEGINNER'S GUIDE TO MODELLING
140 pages. English and Spanish editions

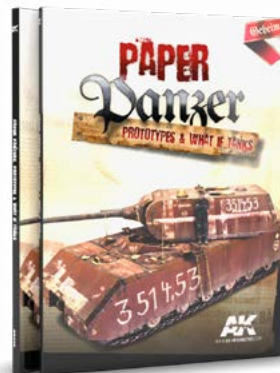

AK246
PAPER PANZER: PROTOTYPES & WHAT IF TANKS
212 pages. English edition



AK278
USN LEGENDARY JETS
192 pages. English and Spanish editions



AK280
LITTLE WARRIORS
96 pages. English and Spanish editions



AK287
ABANDONED: LITTLE TREASURES
140 pages. English edition
AK INTERACTIVE / 118



AK918
WRECKED PLANES
146 pages. Bilingual English / Spanish edition



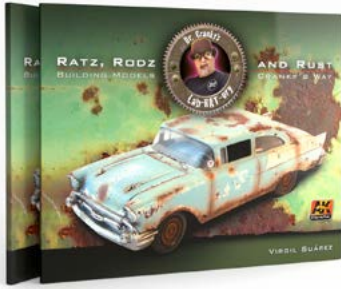

AK090
RATZ, RODZ AND RUST
 120 pages. English edition

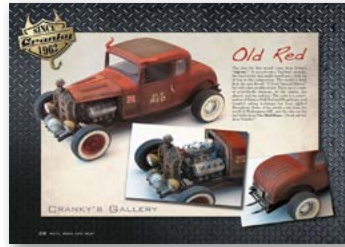

AK687
THE EAGLE HAS LANDED
 292 pages. English and Spanish editions

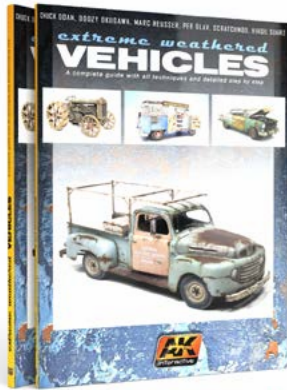

AK404
EXTREME WEATHERED VEHICLES
 132 pages. English edition



AK307
EXTREME REALITY
 130 pages. English edition



AK503
EXTREME SQUARED
 252 pages. English edition

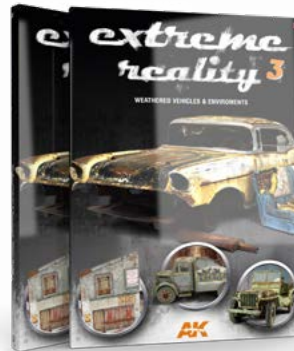

AK510
EXTREME REALITY 3
 140 pages. English and Spanish editions

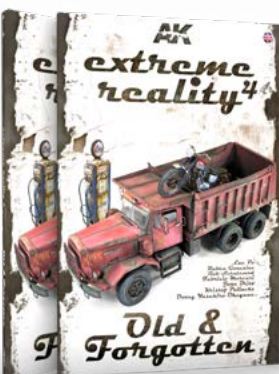
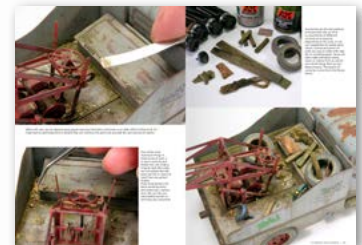

AK511
EXTREME REALITY 4
 136 pages. English edition



AK666
CHINESE POWER
 244 pages. English edition



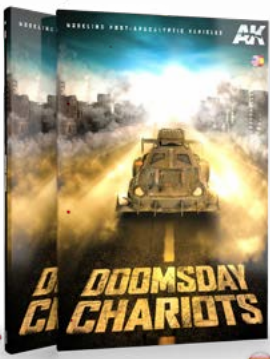

AK258
DODMSDAY CHARIOTS – MODELING POST-APOCALYPTIC VEHICLES
104 pages. Bilingual English / Spanish edition



AK696
TRAINSPOTTING
212 pages. English and Spanish editions



AK914 / AK915
T-54 / T-55 MODELING WORLD'S MOST ICONIC TANK
176 pages. English and Spanish editions

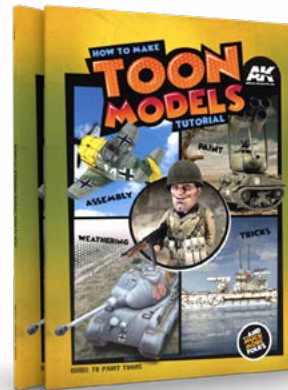

AK911
HOW TO MAKE TOON MODELS
156 pages. English edition

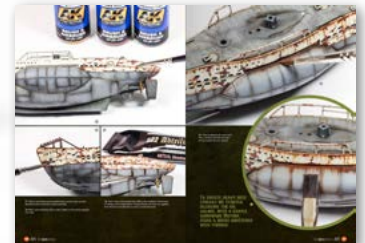

AK514 / AK515
SS MOST ICONIC VEHICLES
164 pages. English and Spanish editions



AK516 / AK517
SS MOST ICONIC VEHICLES 2
172 pages. English and Spanish editions



AK297 / AK298
CONDEMNATION
196 pages. English and Spanish editions
AK INTERACTIVE / 120



AK293 / AK294
HOW TO WORK WITH COLORS AND TRANSITIONS WITH ACRYLICS
216 pages. English and Spanish editions



WORNART COLLECTION

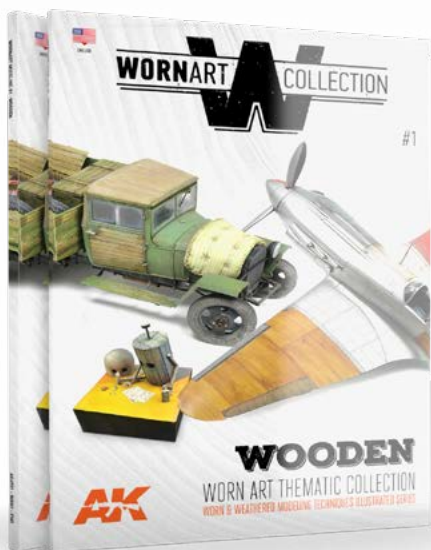

AK4901 / AK4902 EXTREME WEATHERED VEHICLES

92 pages. English and Spanish editions



AK4903 / AK4904 WORN ART COLLECTION #02 CHIPPING

124 pages. English and Spanish editions



AK4905 / AK4906 WORN ART COLLECTION #03 CHERNOBYL

120 pages. Bilingual edition.

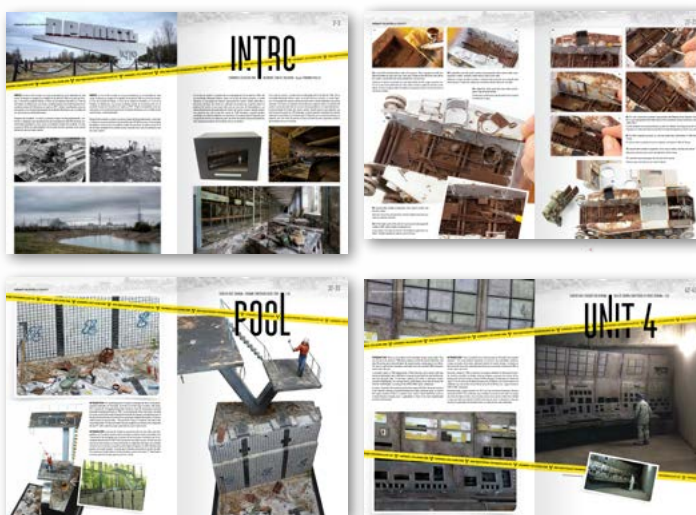

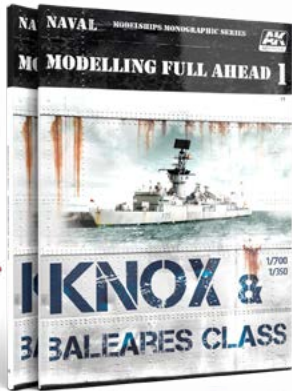

AK098
MODELLING FULL AHEAD 1: KNOX & BALEARES CLASS
 80 pages. English and Spanish editions



AK895
MODELLING FULL AHEAD 2: NEW ORLEANS CLASS
 104 pages. English and Spanish editions

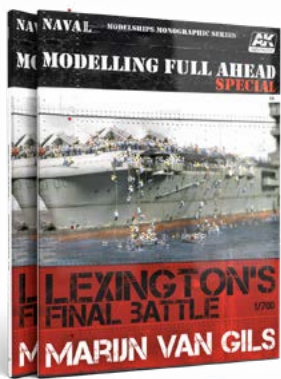

AK667
MODELLING FULL AHEAD SPECIAL 1: LEXINGTON'S FINAL BATTLE
 80 pages. English and Spanish editions

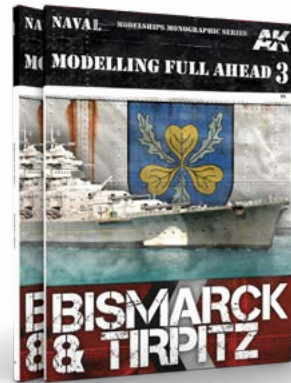
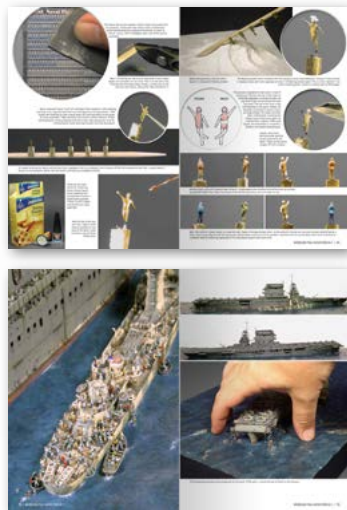

AK249
MODELLING FULL AHEAD 3: BISMARCK & TIRPITZ
 88 pages. English and Spanish editions



10.1.4 PROFILE GUIDES/ GUÍAS DE PERFILES

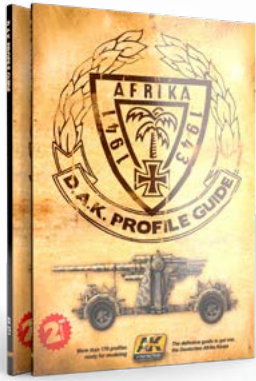

AK271
D.A.K. PROFILE GUIDE
 112 pages. Over 170 color profiles.
 English edition

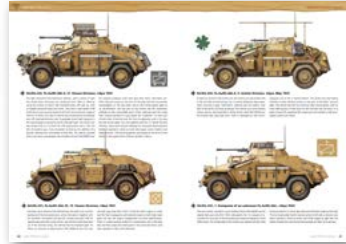

AK916 / AK917
1944 GERMAN ARMOUR IN NORMANDY CAMOUFLAGE PROFILE GUIDE
 112 pages. Over 190 color profiles.
 English and Spanish editions



AK273
WWI THE FIRST MECHANIZED WAR
 172 pages. Over 120 photos and 100 color profiles.
 English edition

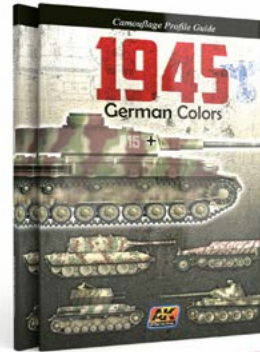

AK403
1945 GERMAN COLORS. CAMOUFLAGE PROFILE GUIDE
 76 pages. Over 180 color profiles.
 English edition



AK284
MIDDLE EAST WARS 1948-1973. MODERN CONFLICTS PROFILE GUIDE VOL. I
 108 pages. Over 120 color profiles.
 English edition



AK285
WARS IN LEBANON 1958-2017. MODERN CONFLICTS PROFILE GUIDE VOL. II
 100 pages. Over 120 color profiles.
 English edition

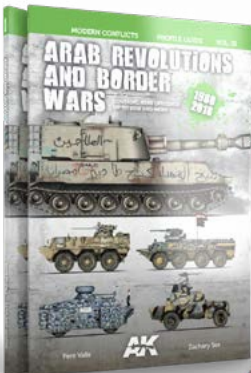

AK286
ARAB REVOLUTIONS & BORDER WARS 1980-2018. MODERN CONFLICTS PROFILE GUIDE VOL. III
 152 pages. Over 170 profiles.
 English edition

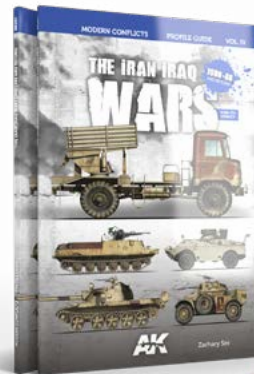

AK291
THE IRAN-IRAQ WARS. MODERN CONFLICTS PROFILE GUIDE VOL. IV
 140 pages. Over 190 color profiles.
 English edition



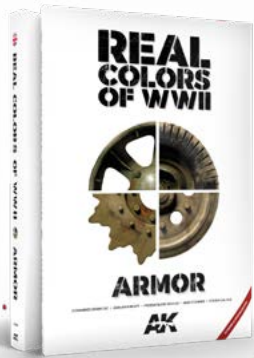

AK299
REAL COLORS OF WWII ARMOR NEW 2ND EXTENDED & UPDATED VERSION
 228 pages. English editions



AK290
REAL COLORS OF WWII AIRCRAFT
 292 pages. 390 photos. 42 color profiles. English edition



10.1.5 HISTORY BOOK/ LIBROS HISTÓRICOS

ABTEILUNG502 BOOKS / LIBROS DE ABTEILUNG502

Abteilung 502 releases some very special publications in the form of books and manuals that are designed to help modelers with their skills, as well as add to the libraries of both fans and collectors. Abteilung 502 only releases publications which stand out from others, while following the philosophy of exclusive luxury goods for modelers.

Abteilung 502 edita algunas publicaciones muy especiales en forma de libros y manuales que están concebidos para ayudar a los modelistas con sus habilidades, así como para agregar a las bibliotecas de aficionados y coleccionistas. Abteilung 502 solo realiza publicaciones que se destaquen de otras, mientras sigue la filosofía de los productos de lujo exclusivos para los modelistas.



ABT601
PANTHER EXTERNAL APPEARANCE & DESIGN CHANGES
 Authored by Roddy MacDougall and Martin Block. 284 pages. English edition
Escrito por Roddy MacDougall y Martin Block. 284 páginas. Edición en inglés

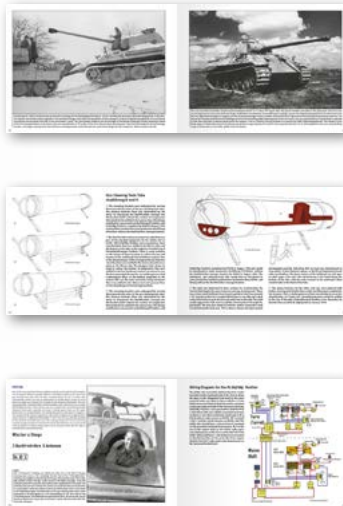

ABT602
MASTERING OILS 1. OIL PAINTING TECHNIQUES ON AFVS
 Authored by Joaquin García Gazquez. 124 pages. English, Spanish, German and French editions
Escrito por Joaquin García Gazquez. 124 páginas. Ediciones en inglés, español, alemán y francés.

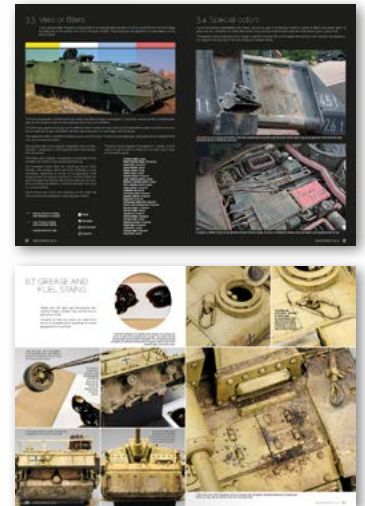

Abteilung 502

It's not the best because it's expensive,
 It is expensive because it is the best.



AK LEARNING SERIES 6

AK LEARNING SERIES

TECHNIQUES TO PAINT ALL TYPES OF FLESH IN MINIATURES

FLESH & SKIN



FLESH & SKIN TECHNIQUES TO PAINT ALL TYPES OF FLESH IN MINIATURES

NOW THERE IS NO EXCUSE TO PAINT FIGURES LIKE A PRO

All the secrets to paint skins and flesh in your figures by the hands of the best modelers.



FIGURE SERIES



YouTube

www.ak-interactive.com
Phone & Fax: (+34) 941 22 30 64
info@ak-interactive.com



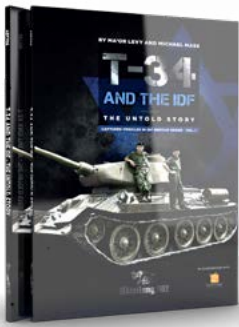

ABT709
T-34 AND THE IDF
THE UNTOLD STORY

Author by Ma'or Levy and Michael Mass. 88 pages. English edition
Escrito por Ma'or Levy y Michael Mass. 88 páginas. Edición en inglés.

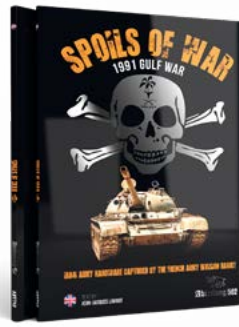
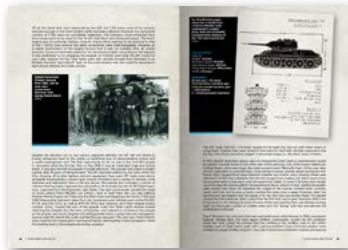

ABT710
SPOILS OF WAR

Author by Jean-Jacques Labrot. 108 pages. English edition
Escrito por Jean-Jacques Labrot. 108 páginas. Edición en inglés.



ABT715
THE SECRETS OF LEVIATHAN:
SCULPTING & PAINTING TECHNIQUES

Author by Michael Kontraras. 120 pages. English edition
Escrito por Michael Kontraras. 120 páginas. Edición en inglés.



ABT718
PANZERDIVISIONEN

Author by Ricardo Recio Cardona. 348 pages. English and Spanish editions
Escrito por Ricardo Recio Cardona. 348 páginas. Ediciones en inglés y español.

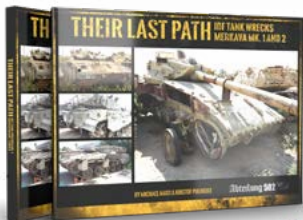

ABT606
THEIR LAST PATH, IDF TANK WRECKS
MERKAVA MK.1 & MK.2

Author by Michael Mass and Kristof Pulinckx. 220 pages. English edition
Escrito por Michael Mass y Kristof Pulinckx. 220 páginas. Edición en inglés.

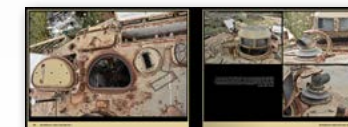

ABT720
DEUTSCHE PANZER

Author by Carlos de Diego Vaquerizo and Ricardo Recio Cardona. 108 pages. English and Spanish editions
Escrito por Carlos de Diego Vaquerizo y Ricardo Recio Cardona. 108 páginas. Ediciones en inglés y español.

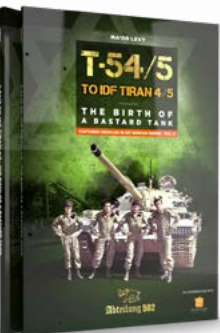

ABT607
T-54/5 TO IDF TIRAN 4/5
THE BIRTH OF A BASTARD TANK

Author by Ma'or Levy. 88 pages. English edition
Escrito por Ma'or Levy. 88 páginas. Edición en inglés.



ABT724
STURMGESCHÜTZ

Author by Ricardo Recio Cardona and Carlos de Diego Vaquerizo. 118 pages. English and Spanish editions
Escrito por Ricardo Recio Cardona y Carlos de Diego Vaquerizo. 118 páginas. Ediciones en inglés y español.





ABT730
DEUTSCHE UNIFORMEN 1919-1945 THE
UNIFORM OF THE GERMAN SOLDIER.
VOLUME I: 1919 - 1935

Authored by Ricardo Recio Cardona. 210 pages.
 English and Spanish editions
 Escrito por Ricardo Recio Cardona. 210 páginas.
 Ediciones en inglés y español.

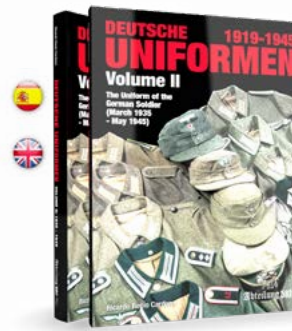

ABT738
DEUTSCHE UNIFORMEN 1919-1945 THE
UNIFORM OF THE GERMAN SOLDIER.
VOLUME II: 1935 - 1945

Authored by Ricardo Recio Cardona. 256 pages.
 English and Spanish editions
 Escrito por Ricardo Recio Cardona. 256 páginas.
 Ediciones en inglés y español.



ABT608
1982 - INVASION OF LEBANON
SAMER KASSIS

Authored by Samer Kassis. 300 pages. English
 edition
 Escrito por Samer Kassis. 300 páginas. Edición
 en Inglés.



ABT713
AIRCRAFT OF THE SPANISH CIVIL WAR
1936-1939

232 pages. English and Spanish editions
 232 páginas. Edición en inglés y español.



ABT722
PANZERWAFFE TARNFARBEN
CAMOUFLAGE COLOURS AND
ORGANIZATION OF THE GERMAN
ARMoured FORCE (1917-1945)

128 pages. English and Spanish editions
 128 páginas. Edición en inglés y español.



ABT609
СОВЕТСКОЕ ОБОРУДОВАНИЕ
SOVIET ARMoured FORCE
(1939-1945)

Authored by Carlos de Diego Vaquerizo and
 Cristóbal Vergara Durán. 132 pages. English
 and Spanish edition.
 Escrito por Carlos de Diego Vaquerizo and
 Cristóbal Vergara Durán. 132 páginas. Edición
 en inglés y español.

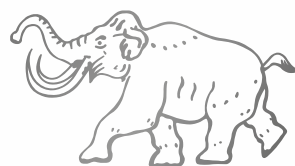

Abteilung 502

10.2 MAGAZINES / REVISTAS

Our range of modeling publications includes various magazines aimed at fans of different modeling genres. Their common features are high quality of images and printing and contribution of the very best modelers from around the world who reveal their secrets and tricks to the readers.
 Nuestra gama de publicaciones de modelismo incluye varias revistas dirigidas a fanáticos de diferentes géneros. Sus características comunes son la alta calidad de las imágenes y la impresión y la contribución de los mejores modelistas de todo el mundo que revelan sus secretos y trucos a los lectores.

10.2.1 ACES HIGH

Aces High is a specialized magazine for scale aircraft modelers. It is divided into several articles, which guide the reader step by step through the processes of building amazing models. Each issue is devoted to a unique theme.

Aces High es una revista especializada para modelistas de aviones a escala. Se divide en varios artículos, que guían al lector paso a paso a través de los procesos de construcción de modelos asombrosos. Cada número está dedicado a un tema único.

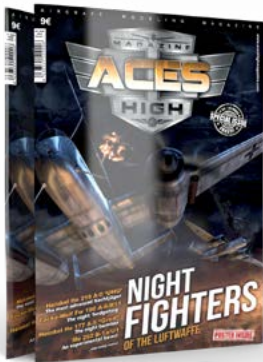

AK2900
ISSUE 1 NIGHT FIGHTERS
 84 pages. English and Spanish editions



AK2902
ISSUE 2 WWI
 72 pages. English and Spanish editions



AK2904
ISSUE 3 THE EMPIRE OF JAPAN
 68 pages. English and Spanish editions



AK2906
ISSUE 4 THE MEDITERRANEAN
 68 pages. English and Spanish editions

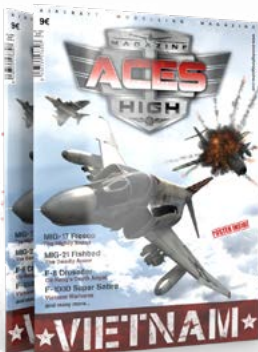

AK2908
ISSUE 5 VIETNAM
 80 pages. English and Spanish editions



AK2910
ISSUE 6 THE BATTLE OF BRITAIN
 84 pages. English and Spanish editions



AK2912
ISSUE 7 SILVER WINGS
 84 pages. English and Spanish editions



AK2914
ISSUE 8 CAPTURED!
 84 pages. English and Spanish editions



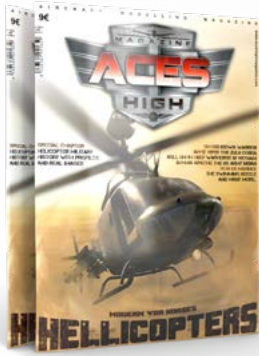

AK2916
ISSUE 09 HELICOPTERS
84 pages. English and Spanish editions



AK2919
ISSUE 10 EASTERN FRONT
76 pages. English and Spanish editions



AK2921
ISSUE 11 FW 190 DER WÜRGER
76 pages. English and Spanish editions



AK2923
ISSUE 12 HYDRO
76 pages. English and Spanish editions

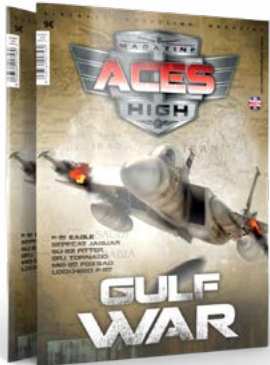

AK2927
ISSUE 13 THE GULF WAR
80 pages. English and Spanish editions



AK2929
ISSUE 14 TWIN-ENGINE WARRIORS
80 pages. English and Spanish editions



AK2931
ISSUE 15 FRENCH JET FIGHTERS
76 pages. English and Spanish editions



AK2933
ISSUE 16 NORMANDY D-DAY
76 pages. English and Spanish editions





AK2935
ISSUE 17 TORPEDO ACHTUNG!!
 88 pages. English and Spanish editions



AK2937
ISSUE 18 TRAINERS
 88 pages. English and Spanish editions



ACES HIGH SPECIALS

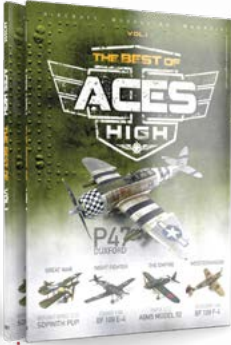

AK2925
THE BEST OF ACES HIGH
MAGAZINE VOL.1
 108 pages. English edition



AK2926
THE BEST OF ACES HIGH
MAGAZINE VOL.2
 104 pages. English edition



AK2918
HIND SPECIAL
 144 pages. English edition

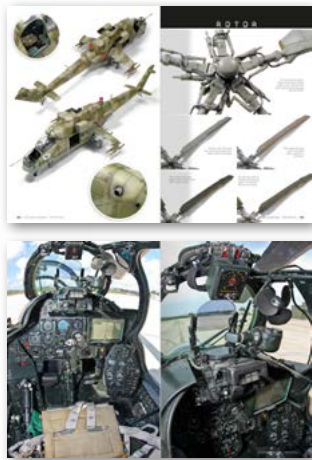

10.2.2 TANKER TECHNIQUES MAGAZINE

As the title suggest, Tanker is a magazine focused on modeling techniques useful for fighting vehicle hobbyists. In each issue you'll find step-by-step articles written by some of the best modelers from around world, who share their secrets with our readers. Como sugiere el título, Tanker es una revista centrada en técnicas de modelismo útiles para los aficionados de los vehículos. En cada número, encontrará artículos paso a paso escritos por algunos de los mejores modelistas de todo el mundo, que comparten sus secretos con nuestros lectores.



AK4810
ISSUE 1 EXTREME RUST
 100 pages. English, Spanish, Russian, German, French, Czech, Hungarian and Chinese editions



AK4812
ISSUE 2 EXTRA ARMOR
 104 pages. English, Spanish, French, and Hungarian editions





AK4817
ISSUE 3 DUST AND DIRT
 108 pages. English, Spanish and Hungarian editions



AK4820
ISSUE 4 DAMAGE INC.
 92 pages. English, Spanish and Hungarian editions

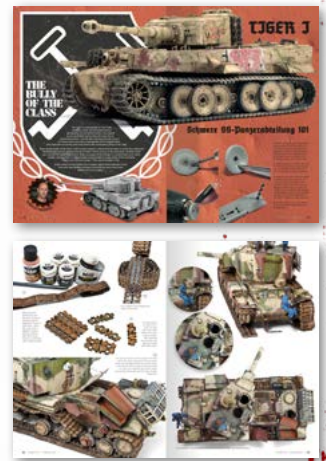

AK4823
ISSUE 5 MUD AND EARTH
 88 pages. English, Spanish and Hungarian editions



AK4826
ISSUE 6 STEEL CATS
 84 pages. English, Spanish and Hungarian editions



AK4829
ISSUE 7 URBAN WAR
 92 pages. English, Spanish and Hungarian editions



AK4832
ISSUE 8 BEASTS OF WAR
 88 pages. English, Spanish and Hungarian editions



AK4835
ISSUE 9 RARITIES & VARIANTS
 88 pages. English, Spanish and Hungarian editions



AK4838
ISSUE 10 SPECIAL EDITION
 80 pages. English, Spanish, German and Hungarian editions





AK4844

TANKER SPECIAL IDF 01

114 pages. Bilingual English / Spanish edition

This special edition of Tanker magazine is focused on the Israel Defense Forces armoured vehicles. It is an excellent step-by-step guide on creating realistic miniatures of IDF AFVs in 1/35 scale. Our goal is to provide artistic inspiration and necessary guidance for your future projects. This is the first volume of the two that will feature the most iconic tanks and armoured vehicles of the Israel Defense Forces. Prepared in strict collaboration with Michael Mass of Desert Eagle Publishing!

Esta edición especial de la revista Tanker se centra en los vehículos blindados de las Fuerzas de Defensa de Israel. Es una excelente guía paso a paso sobre la creación de miniaturas realistas de AFV de las FDI en escala 1/35. Nuestro objetivo es brindar la inspiración artística y la orientación necesaria para sus proyectos futuros. Este es el primer volumen de los dos que contará con los tanques y vehículos blindados más emblemáticos de las Fuerzas de Defensa de Israel. Preparado en estricta colaboración con Michael Mass de Desert Eagle Publishing.



AK4842
ISSUE 11 SPECIAL WINTER
220 pages. English edition



AK4845
TANKER SPECIAL IDF 02

112 pages. Bilingual English / Spanish edition

This special edition of Tanker magazine is focused on the Israel Defense Forces armoured vehicles. It is an excellent step-by-step guide on creating realistic miniatures of IDF AFVs in 1/35 scale. Our goal is to provide artistic inspiration and necessary guidance for your future projects. This is the second volume of the two that will feature the most iconic tanks and armoured vehicles of the Israel Defense Forces. Prepared in strict collaboration with Michael Mass of Desert Eagle Publishing!

Esta edición especial de la revista Tanker se centra en los vehículos blindados de las Fuerzas de Defensa de Israel. Es una excelente guía paso a paso sobre la creación de miniaturas realistas de AFV de las FDI en escala 1/35. Nuestro objetivo es brindar la inspiración artística y la orientación necesaria para sus proyectos futuros. Este es el segundo volumen de los dos que contará con los tanques y vehículos blindados más emblemáticos de las Fuerzas de Defensa de Israel. Preparado en estricta colaboración con Michael Mass de Desert Eagle Publishing.

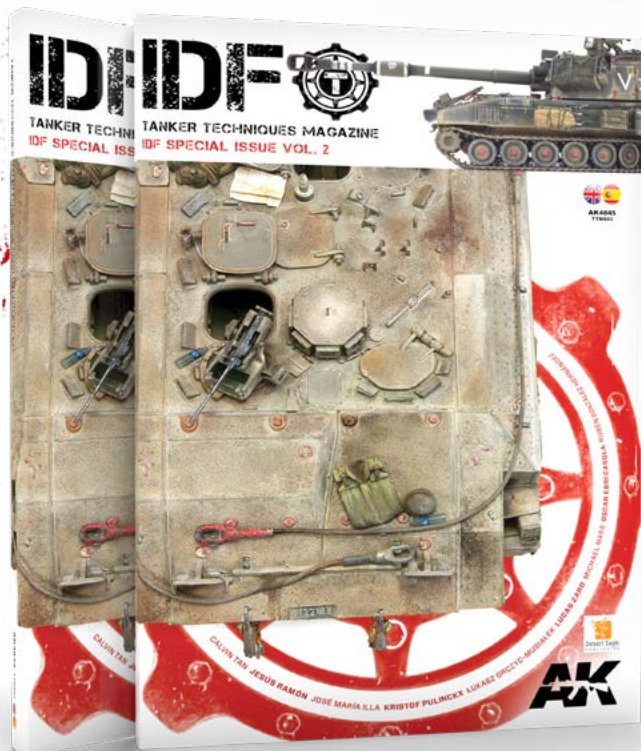

**ALL YOU
NEED FOR
MODELING**



**REGARDLESS
OF YOUR
FAVORITE GENRE**



WWW.AK-INTERACTIVE.COM



10.2.3 DAMAGED MAGAZINE / REVISTA DAMAGED

Damaged is a very special magazine developed to inspire modelers and show them new possibilities in the hobby. In each issue we invite you to a great journey through different modeling genres and really uncommon subjects. The articles are prepared in step-by-step style and are illustrated with high quality photos, allowing to explain different building, painting and weathering techniques and notice interesting details created by the authors.

Damaged es una revista muy especial desarrollada para inspirar a los modelistas y mostrarles nuevas posibilidades en el hobby. En cada número te invitamos a un gran viaje a través de diferentes géneros de modelismo y temas realmente poco comunes. Los artículos se preparan en un estilo paso a paso y se ilustran con fotos de alta calidad, lo que permite explicar diferentes técnicas de construcción, pintura y meteorización y notar detalles interesantes creados por los autores.



ABT701
ISSUE 1

76 pages. English & Spanish editions



ABT703
ISSUE 2

80 pages. English & Spanish editions



ABT705
ISSUE 3

80 pages. English & Spanish editions



ABT707
ISSUE 4

80 pages. English & Spanish editions



ABT711
ISSUE 5

80 pages. English & Spanish editions



ABT716
ISSUE 6

80 pages. English & Spanish editions



ABT726
ISSUE 7

76 pages. English & Spanish editions



ABT728
ISSUE 08

72 pages. English & Spanish editions

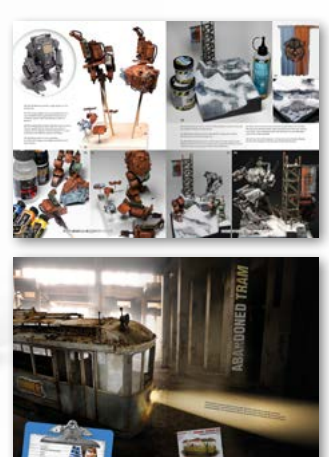



ABT734
ISSUE 09
72 pages. English & Spanish editions



ABT736
ISSUE 10
72 pages. English & Spanish editions



ABT740
ISSUE 11
72 pages. English & Spanish editions

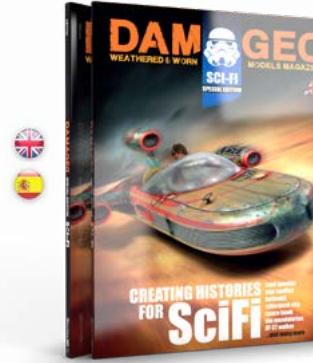
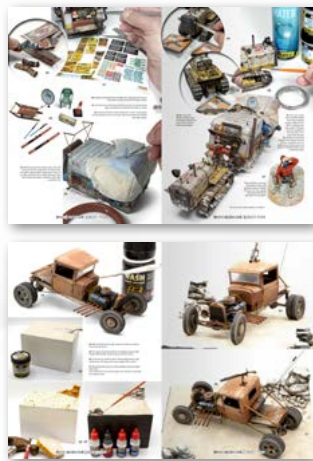

ABT732
DAMAGED – SPECIAL SCIFI BOOK
116 pages. English & Spanish editions



10.2.4 AKTION MAGAZINE / REVISTA AKTION

Aktion magazine is specially designed for wargame lovers. The articles are always prepared with the player in mind so he/she can easily adapt the presented techniques for finishing his/her kits and accessories for the battle in an attractive and quick way. La revista AKtion está especialmente diseñada para los amantes de los juegos de guerra. Los artículos siempre se preparan pensando en el jugador para que pueda adaptar fácilmente las técnicas presentadas para terminar sus kits y accesorios para la batalla de una manera atractiva y rápida.



AK6300
ISSUE 1
88 pages. English, Spanish & French editions



AK6303
ISSUE 2
64 pages. English & Spanish editions



AK6305
ISSUE 3
72 pages. English & Spanish editions



11

MERCHANDISING

11.1 SPECIAL BAGS & DELUXE TRANSPORT BOXES/ MALETAS ESPECIALES Y CAJAS DE TRANSPORTE DE LUJO

Our high quality stitched bags are specially developed for transporting AK Interactive acrylic paints and weathering products, but the different foam inserts will allow you to safely take almost everything else you need to your modelling club meeting, painting class, model show or even on holiday. The bags have different finishes and are offered with various combinations of foam inserts. The latter can also be purchased separately.

Nuestras bolsas cosidas de alta calidad están especialmente desarrolladas para el transporte de pinturas acrílicas AK y productos de envejecimiento, pero las diferentes inserciones de foam troquelado le permitirán llevar casi todo lo demás que necesite a la reunión de su club de modelismo, a la clase de pintura, al model show o incluso de vacaciones. Las bolsas tienen diferentes acabados y se ofrecen con varias combinaciones de espuma troquelada. Estas últimas también se puede comprar por separado.

AK11701 TRANSPORT CASE 236 COLORS

11 Kg. Transport case with safety locks. Includes 2 keys and shoulder strap. Elegant briefcase limited edition. The 3 gen colors have been a great advance in the world of acrylic and many modellers have already changed their way of painting, surprised by their properties and pigmentation. Prepared for painting with a brush, they are the paints that perform the best and it works with the airbrush once dissolved to your liking.

11 Kg. Maletín de transporte con cierres de seguridad. Incluye 2 llaves y bandolera. Elegante maletín edición limitada. Los colores 3 gen han supuesto un gran avance en el mundo del acrílico y muchos modelistas ya han cambiado su forma de pintar sorprendidos por sus propiedades y pigmentación. Preparados para pintar con pincel son las pinturas que mejor rinden y funciona con el aerógrafo una vez disueltas a tu gusto.



AK11702 TRANSPORT CASE 100 COLORS

5 Kg. Transport case with safety locks. Includes 2 keys. Elegant briefcase limited edition. The 3 gen colors have been a great advance in the world of acrylic and many modellers have already changed their way of painting, surprised by their properties and pigmentation. Prepared for painting with a brush, they are the paints that perform the best and it works with the airbrush once dissolved to your liking.

5 Kg. Maletín de transporte con cierres de seguridad. Incluye 2 llaves. Elegante maletín edición limitada. Los colores 3 gen han supuesto un gran avance en el mundo del acrílico y muchos modelistas ya han cambiado su forma de pintar sorprendidos por sus propiedades y pigmentación. Preparados para pintar con pincel son las pinturas que mejor rinden y funciona con el aerógrafo una vez disueltas a tu gusto.





AK11700
HAND CRAFTED WOODEN SPECIAL DELUXE BOX

Deluxe wooden box, with two drawers containing 230 3rd Generation Acrylics. The best way to keep your paints safe and organized. A very exclusive box and limited units, GET YOURS!!!
Caja de lujo en madera, con dos cajones que contienen 230 Acrílicos de Tercera Generación. La mejor manera de mantener tus pinturas seguras y organizadas. Una caja muy exclusiva y en unidades limitadas, ¡CONSIGUE LA TUYA!



RC WOOD AFV
WOODEN TRANSPORT BOX, REAL COLORS SPECIAL EDITION

A special edition wooden transport box including 114 jars of Real Colors (basic and AFV colors + varnishes).

Una caja de transporte de madera de edición especial que incluye 114 botes de colores reales (colores básicos y AFV + barnices).



RC WOOD AIR
WOODEN TRANSPORT BOX, REAL COLORS AIR SPECIAL EDITION

A special edition wooden transport box including 133 jars of Real Colors intended for aircraft painting.

Una caja de transporte de madera de edición especial que incluye 133 botes de colores reales para pintar aviones.



AK10047
WEATHERING PENCILS: DELUXE EDITION BOX

Luxury edition box containing 37 watercolor pencils for easy transport. A high quality box to keep your special pencils safe and ready for the most extreme weathering, get it now!!!

Estuche de edición de lujo que contiene 37 lápices de acuarela para un fácil transporte. ¡Una caja de alta calidad para mantener tus lápices especiales seguros y listos para los efectos más extremos!

AK10048
WEATHERING PENCILS FULL RANGE CASE

Embroidered fabric case. Contains 37 pencils for easy portability. A high-quality fabric pouch to keep your special pencils stowed away and ready to use at any time!

Estuche bordado de tela. Contiene 37 lápices para un fácil transporte. ¡Un estuche de tela de alta calidad para mantener tus lápices especiales guardados y listos para usar en cualquier momento.



11.2 MERCHANDISING

RC700 REAL COLORS COASTERS



Collectibles item. 1mm thick square cardboard printed in high definition. Whether you are a coaster collector or a fan of military profiles you cannot be without this limited collection of coasters designed by Tomek Wajnkaim.
Artículo de coleccionismo. Cartón cuadrado de 1 mm de grosor impreso en alta definición. Si eres un coleccionista de posavasos o un fanático de los perfiles militares, no puedes dejar escapar esta colección limitada de posavasos diseñados por Tomek Wajnkaim.



AK907D
AK KEYCHAIN



AK907
AK KEYCHAIN



PINAK2020
PIN AK 2020

AK908C AK LOGO WHITE CERAMIC MUG



Ceramic mug with AK logo.
Color white.
Capacity: 290 ml.
*Taza de cerámica con logo AK.
Color blanco.
Capacidad: 290 ml.*

AK908D AK LOGO BLACK CERAMIC MUG



Ceramic mug with AK logo.
Color black.
Capacity: 290 ml.
*Taza de cerámica con logo AK.
Color negro.
Capacidad: 290 ml.*

M
L
XL
XXL



AK051
OFFICIAL AK T-SHIRT

CLASSIC X CAMO

MASKS COVID-19



AK9098
CLASSIC CAMOUFLAGE FACE MASK 01



AK9099
CLASSIC CAMOUFLAGE FACE MASK 02



AK9158
CLASSIC CAMOUFLAGE FACE MASK 03



AK9159
CLASSIC CAMOUFLAGE FACE MASK 04

URBAN X CAMO

Special designs made by visual artist Carlos Corres.
Diseños especiales realizados por el artista visual Carlos Corres.



AK9096
URBAN CAMOUFLAGE FACE MASK 1



AK9097
URBAN CAMOUFLAGE FACE MASK 2

MIG★
productions

Abteilung 502 

WERE THE SCENERY DEPOT!
Doozy!
PRODUCTIONS

AK

DAMAGED
WEATHERED & WORN
MODELS MAGAZINE

TANKER
TECHNIQUE & INSPIRATION

MAKING
ACES
HIGH

WARGAME
AKTION

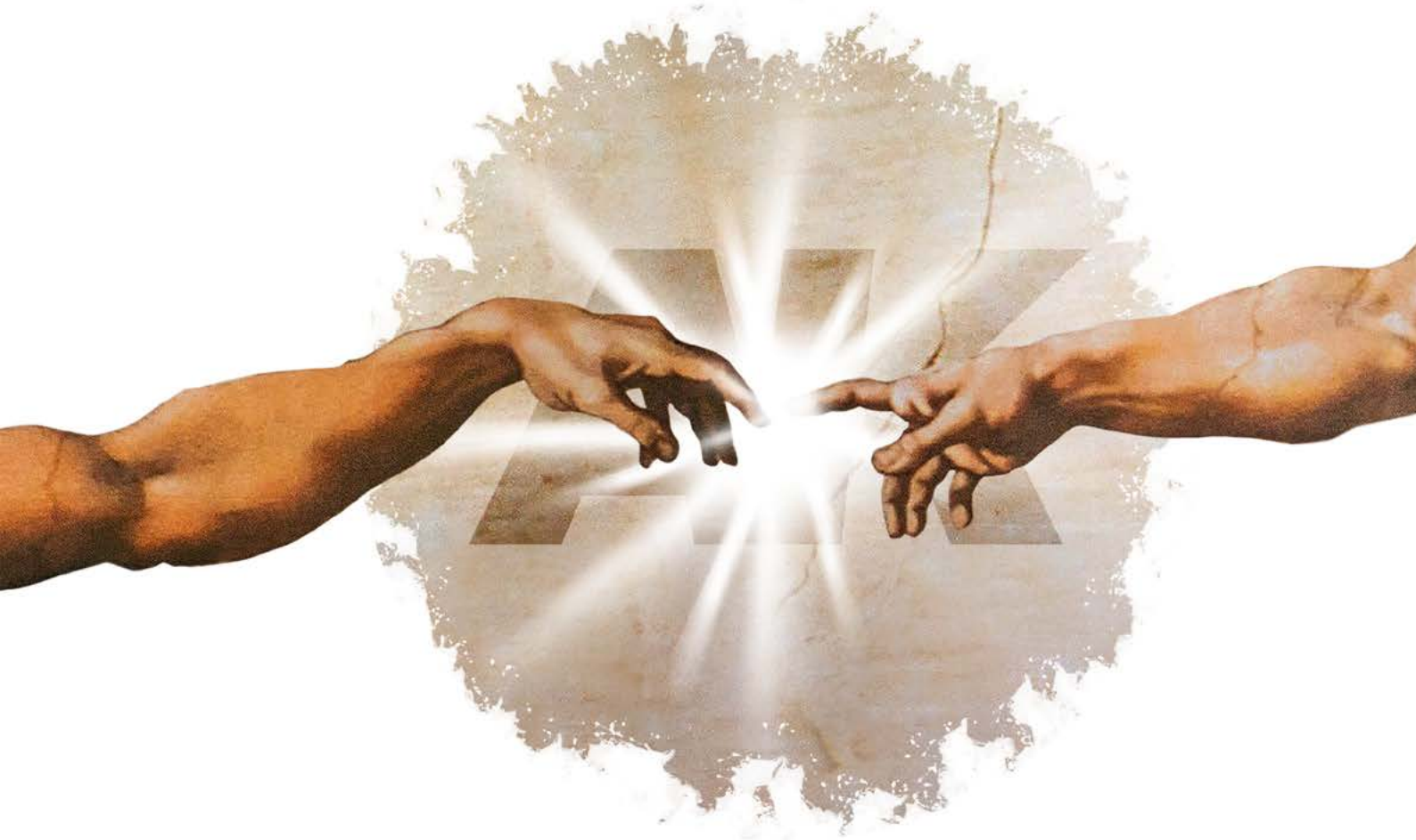

THE ORIGINAL BRAND

UNBEATEABLE MODELING PRODUCTS



WWW.AK-INTERACTIVE.COM

11.3 DISPLAY RACKS / EXPOSITORES

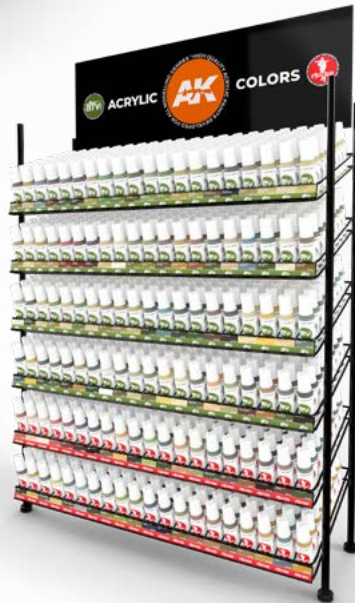

TABLE TOP ACRYLICS DISPLAY RACK

Height / Altura: 873 mm
 Width / Anchura: 630 mm
 Depth / Profundidad: 348 mm

ACRYLICS AFV & FIGURE SERIES 3RD GENERATION 80 AFV COLORS + 40 FIGURE COLORS

Height / Altura: 873mm
 Width / Anchura: 630mm
 Depth / Profundidad: 348mm



FULL ACRYLICS DISPLAY RACK

Height / Altura: 1942 mm
 Width / Anchura: 630 mm
 Depth / Profundidad: 348 mm



ACRYLICS 3RD GENERATION 80 AFV COLORS + 40 FIGURE COLORS + 120 SELECTED COLORS

Height / Altura: 1942mm
 Width / Anchura: 630mm
 Depth / Profundidad: 348mm



WEATHERING PENCILS RACK

Height / Altura: 326mm
 Width / Anchura: 228mm
 Depth / Profundidad: 147mm

EXTRA THIN QUICK CEMENT EXPOSITOR



EXTRA THIN CEMENT EXPOSITOR



STANDARD DENSITY PLASTIC CEMENT EXPOSITOR



EXTRA THIN CITRUS CEMENT EXPOSITOR



WOLVERINE P.V.A. GLUE

MAGNET CYANOACRYLATE 99% EXPOSITOR



BLACK WIDOW CYANOACRYLATE EXPOSITOR



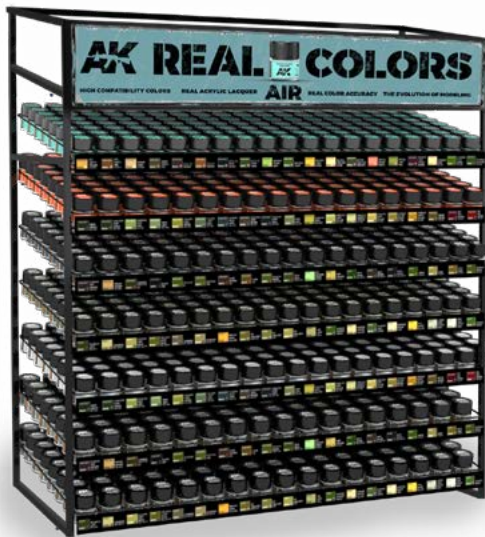

Height / Altura: 770mm
 Width / Anchura: 790mm
 Depth / Profundidad: 290mm
 Weight / Peso: 22Kg.

REAL COLORS AIR RACK



REAL COLORS AFV & STANDARD RACK

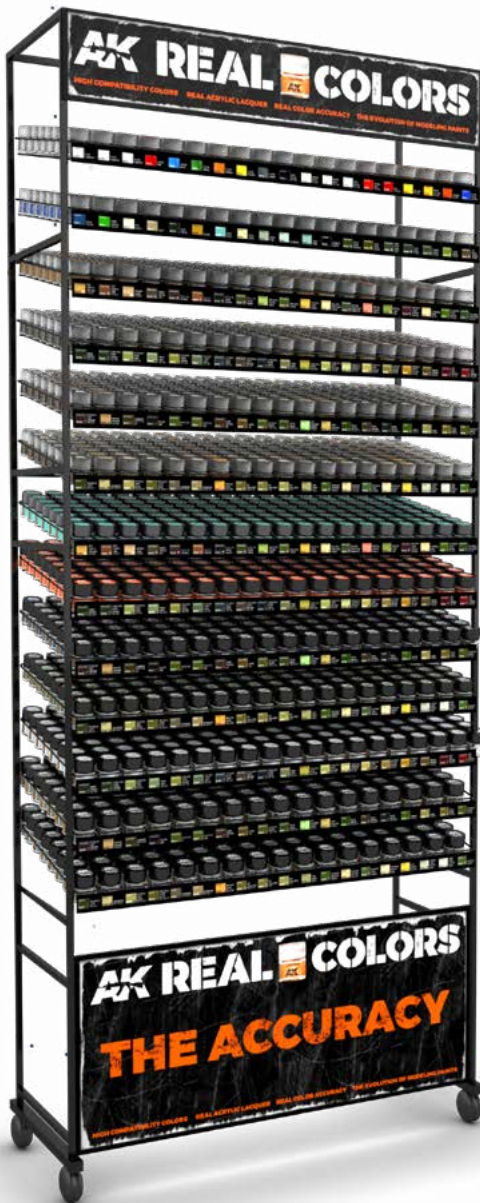

REAL COLORS AFV & STANDARD + AIR RACK

ACRYLICS AIRCRAFT RACK

Height / Altura: 750mm
 Width / Anchura: 612mm
 Depth / Profundidad: 235mm
 Weight / Peso: 14Kg.



BRUSHES RACK

Height / Altura: 690mm
 Width / Anchura: 675mm
 Depth / Profundidad: 345mm





DIORAMA SERIES RACK
 Height / Altura: 1900mm
 Width / Anchura: 517mm
 Depth / Profundidad: 366mm



ENAMELS RACK
 Height / Altura: 1900mm
 Width / Anchura: 450mm
 Depth / Profundidad: 405mm



PANELINERS DISPLAY

PRIMERS DISPLAY



VARNISHES DISPLAY





PIGMENTS RACK

Height / Altura: 525mm
 Width / Anchura: 350mm
 Depth / Profundidad: 255mm



SPRAYS RACK

Height / Altura: 940mm
 Width / Anchura: 380mm
 Depth / Profundidad: 353mm

TRUE METAL RACK

Height / Altura: 570mm
 Width / Anchura: 380mm
 Depth / Profundidad: 280mm



XTREME METAL RACK

Height / Altura: 520mm
 Width / Anchura: 340mm
 Depth / Profundidad: 250mm



AK SPRAYS

HIGH QUALITY SPRAY PAINT FOR MODELLING



400ML.



150ML.



ALL YOU CAN IMAGINE

HIGH QUALITY PAINTS, EASE OF USE, WIDE RANGE OF COLORS & EFFECTS

AK TECH SHEETS



FREE DOWNLOADS ON
AK-INTERACTIVE.COM

MORE THAN **100** TECH SHEETS





THE BEST RESOURCE FOR MODELERS



ALL OUR PUBLICATIONS AT A BETTER PRICE



TONS OF FREE TUTORIALS AND GUIDES



HOURS OF FREE VIDEO TUTORIALS

AK INTERACTIVE
THE APP FOR THE SCALE MODEL LOVERS



SUBSCRIBE TO OUR CHANNEL AND KEEP UPDATED WITH THE LATEST MODELING TUTORIALS AND ALL THE UPCOMING NEWS



DON'T MISS THEM!!!



AK AK Interactive Official
24.358 suscriptores



Usando: AK8012 || HIELO & NIEVE
1 mil visualizaciones · Hace 6 días



How to: AK8012 || ICE & SNOW
2,3 mil visualizaciones · Hace 6 días



Combination of Weathering Pencils and Enamels on a...
5,7 mil visualizaciones · Hace 2 semanas



COMBINACIÓN DE LÁPICES ACUARELABLES Y...
1,4 mil visualizaciones · Hace 2 semanas



Wet Palette || Let's learn #HowToUse it! [Eng SUB +...
7,5 mil visualizaciones · Hace 2 meses
Subtítulos



Weathering #pencils from AK-INTERACTIVE: Chipping ...
1 mil visualizaciones · Hace 3 meses
Subtítulos



Hemos actualizado la app de #AKInteractive!
1,2 mil visualizaciones · Hace 3 meses



We have updated the #AKInteractive app!
2,2 mil visualizaciones · Hace 3 meses



#CÓMOUSAR adecuadamente los Colores...
1,7 mil visualizaciones · Hace 3 meses



#HOWTOUSE Real Colors properly
5,9 mil visualizaciones · Hace 3 meses



Weathering #pencils from AK-INTERACTIVE: Yellow...
16 mil visualizaciones · Hace 3 meses



Weathering #pencils from AK-INTERACTIVE: Applying...
18 mil visualizaciones · Hace 3 meses
Subtítulos

UNBEATEABLE MODELING PRODUCTS



WWW.AK-INTERACTIVE.COM

AK



BOYS!!! YOU DON'T KNOW WHAT
YOU ARE MISSING...

MODELING

THE ORIGINAL BRAND



WWW.AK-INTERACTIVE.COM